

Rotary Servomotors

SGMMV

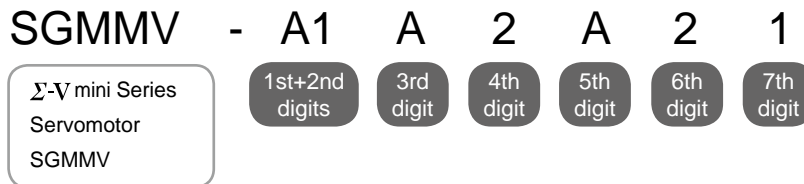

Model Designations



1st+2nd digits Rated Output

Code	Specifications
B3	3.3 W
B5	5.5 W
B9	11 W
A1	10 W
A2	20 W
A3	30 W

5th digit Design Revision Order

Code	Specifications
A	Standard

6th digit Shaft End

Code	Specifications
2	Straight (Standard)
A	Straight with flat seats (Optional)

7th digit Options

Code	Specifications
1	Without options
C	With holding brake (24 VDC, flange size: 25 mm×25 mm)

3rd digit Power Supply Voltage

Code	Specifications
A	200 VAC (Flange size: 25 mm×25 mm)
E	24 VDC/48 VDC*

*: Same for 24 VDC and 48 VDC. Characteristics vary with the voltage of the main circuit for SERVOPACKs

4th digit Serial Encoder

Code	Specifications
2	17-bit absolute

Features

- Ultra-compact, ultra-small capacity
With flange size of 15 mm×15 mm: 3.3 W to 11 W
With flange size of 25 mm×25 mm: 10 W to 30 W
- Mounted 17-bit high-resolution absolute serial encoder:
Can be used as an incremental encoder
- Maximum speed: 6,000 RPM
- Wide selection: Two flange sizes, AC or DC power*, and holding brakes*

*: Only the 25 mm×25 mm flange can be used with a 200-VAC power supply or a holding brake.

Application Examples

Equipment

- Semiconductor equipment
- LCD manufacturing equipment
- Electronic parts assembly and electronic parts manufacturing equipment
- Metal processing machines
- Robots
- Assemblers
- Inspection and measurement devices
- Clean systems
- Automated guided vehicles (AGVs)
- Equipment for biomedical

Machinery

- Bonders, probers, IC handlers, chip sorters, and OHT
- Dispensers, scribe, electrode-mounting device, and inspection device
- Mounters, inserters, and solder printers

- Coil winders and spring machinery
- X-Y robots, assembler robots
- Screw tighters

●Precautions when using AC or DC power input

Applicable servomotors, SERVOPACKs, and cables differ depending on if AC or DC power is used. Refer to the relevant pages and be sure to select the correct models.

With DC power

Applicable servomotors: SGMMV-□□E
Applicable SERVOPACKs: SGD□V-□□□E

- Refer to page x for information on combining servomotors and SERVOPACKs.
- Refer to pages 10 to 14 for information on selecting servomotor cables.

With AC power

Applicable servomotors: SGMMV-□□A
Applicable SERVOPACKs: SGD□V-□□□F and SGD□V-□□□A

- Refer to page ix for information on combining servomotors and SERVOPACKs.
- Refer to pages 15 to 19 for information on selecting servomotor cables.

Ratings and Specifications

Time Rating: Continuous
 Vibration Class: V15
 Insulation Resistance: 500 VDC, 10 MΩ min.
 Ambient Temperature: 0 to 40°C
 Excitation: Permanent magnet
 Mounting: Flange-mounted
 Thermal Class: 15 mm×15 mm B (UL: A)
 25 mm×25 mm B
 Withstand Voltage: 600 VAC for one minute

Enclosure: 15 mm×15 mm: Totally enclosed, self-cooled, IP42
 (except for shaft opening)
 25 mm×25 mm: Totally enclosed, self-cooled,
 IP55 (except for shaft opening)
 Ambient Humidity: 20% to 80% (no condensation)
 Drive Method: Direct drive
 Rotation Direction: Counterclockwise (CCW) with forward run
 reference when viewed from the load side

Voltage		24 VDC/48 VDC ³					
Servomotor Model: SGM MV-□□□□		B3E	B5E	B9E	A1E	A2E	A3E
Rated Output ¹	W	3.3	5.5	11	10	20	30
Rated Torque ^{1, 2}	Nm	0.0105	0.0175	0.0350	0.0318	0.0637	0.0955
Instantaneous Peak Torque ¹	Nm	0.0263	0.0438	0.0875	0.0955	0.191	0.286
Rated Current ¹	A _{rms}	1.5	1.5	1.7	2.1	2.0	2.9
Instantaneous Max. Current ¹	A _{rms}	3.6	3.7	4.1	6.1	5.8	8.6
Rated Speed ¹	RPM	3000					
Max. Speed ¹	RPM	6000					
Torque Constant	Nm/A _{rms}	0.00814	0.0132	0.0241	0.0172	0.0358	0.0358
Rotor Moment of Inertia	kg·m ²	4.41×10 ⁻⁸	7.96×10 ⁻⁸	2.21×10 ⁻⁷	2.72×10 ⁻⁷ (4.07×10 ⁻⁷)	4.66×10 ⁻⁷ (6.02×10 ⁻⁷)	6.68×10 ⁻⁷ (8.04×10 ⁻⁷)
Rated Power Rate ¹	kW/s	2.50	3.85	5.54	3.72	8.71	13.7
Rated Angular Acceleration ¹	rad/s ²	238000	220000	158000	117000	137000	143000
Flange Size	mm	15×15			25×25		
Applicable SERVOPACK	SGDV-□□□□	1R7E			2R9E		

*1: These items and torque-motor speed characteristics quoted in combination with an SGDV SERVOPACK are at an armature winding temperature of 100°C. Other values quoted are at 20°C.

*2: Rated torques are continuous allowable torque values at 40°C with an aluminum heat sink of the following dimensions attached.
 SGM MV-B3E, -B5E, -B9E, -A1E, -A2E: 150 mm×150 mm×3 mm
 SGM MV-A3E : 250 mm×250 mm×6 mm

*3: Torque-speed characteristics differ depending on if a 24 VDC or a 48 VDC is used for the main circuit for the SERVOPACK.

Note: The values in parentheses are for servomotors with holding brakes.

● Torque-Motor Speed Characteristics A : Continuous Duty Zone B : Intermittent Duty Zone

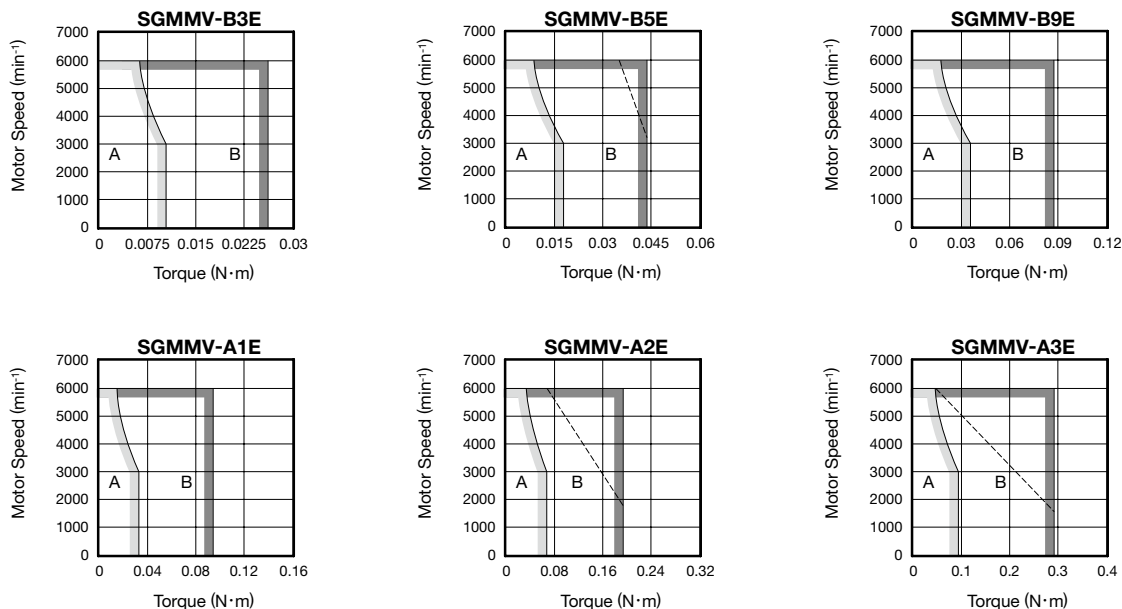

Notes: 1 The characteristics of the intermittent duty zone differ depending on the supply voltage.

Solid lines indicate characteristics when a 48-VDC power supply is applied to the main circuit of the SERVOPACK, and dotted lines indicate characteristics when a 24 VDC is applied.

For SGM MV-B3E, -B9E, -A1E SERVOPACKS, characteristics are the same for both 24-VDC or 48-VDC versions.

2 When the effective torque is within the rated torque, the servomotor can be used within the intermittent duty zone.

Ratings and Specifications

Time Rating: Continuous
 Vibration Class: V15
 Insulation Resistance: 500 VDC, 10 M Ω min.
 Ambient Temperature: 0 to 40°C
 Excitation: Permanent magnet
 Mounting: Flange-mounted
 Thermal Class: B

Withstand Voltage: 1500 VAC for one minute
 Enclosure: Totally enclosed, self-cooled, IP55
 (except for shaft opening)
 Ambient Humidity: 20% to 80% (no condensation)
 Drive Method: Direct drive
 Rotation Direction: Counterclockwise (CCW) with forward run
 reference when viewed from the load side

Voltage		200 VAC		
Servomotor Model: SGMMV-□□□		A1A	A2A	A3A
Rated Output ¹	W	10	20	30
Rated Torque ^{1, 2}	Nm	0.0318	0.0637	0.0955
Instantaneous Peak Torque ¹	Nm	0.0955	0.191	0.286
Rated Current ¹	A _{rms}	0.70	0.66	0.98
Instantaneous Max. Current ¹	A _{rms}	2.0	1.9	2.9
Rated Speed ¹	RPM	3000		
Max. Speed ¹	RPM	6000		
Torque Constant	Nm/A _{rms}	0.0516	0.107	0.107
Rotor Moment of Inertia	kg·m ²	2.72×10 ⁻⁷ (4.07×10 ⁻⁷)	4.66×10 ⁻⁷ (6.02×10 ⁻⁷)	6.68×10 ⁻⁷ (8.04×10 ⁻⁷)
Rated Power Rate ¹	kW/s	3.72	8.71	13.7
Rated Angular Acceleration ¹	rad/s ²	117000	137000	143000
Flange Size	mm	25×25		
Applicable SERVOPACK	SGDV-□□□□	R90□		1R6A, 2R1F

*1: These items and torque-motor speed characteristics quoted in combination with an SGD V SERVOPACK are at an armature winding temperature of 100°C. Other values quoted are at 20°C.

*2: Rated torques are continuous allowable torque values at 40°C with an aluminum heat sink of the following dimensions attached.

SGMMV-A1A, -A2A: 150 mm×150 mm×3 mm

SGMMV-A3A : 250 mm×250 mm×6 mm

Note: The values in parentheses are for servomotors with holding brakes.

● Torque-Motor Speed Characteristics A : Continuous Duty Zone B : Intermittent Duty Zone

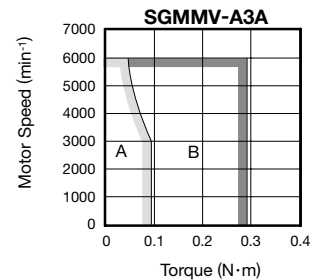
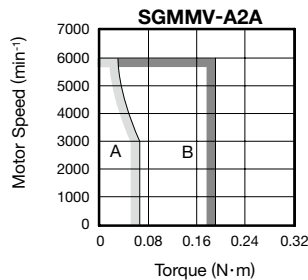
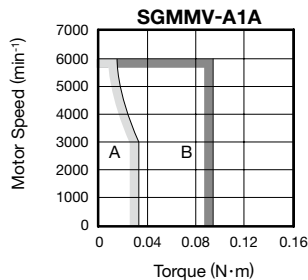

Notes: 1 The characteristics of the intermittent duty zone differ depending on the supply voltage.

2 When the effective torque is within the rated torque, the servomotor can be used within the intermittent duty zone.

Ratings and Specifications

● Holding Brake Electrical Specifications

Holding Brake Rated Voltage	Servomotor Model	Servomotor Rated Output W	Holding Brake Specifications					
			Capacity W	Holding Torque Nm	Coil Resistance Ω (at 20°C)	Rated Current A(at 20°C)	Brake Release Time ms	Brake Operation Time ms
24 VDC $^{+10\%}_0$	SGMMV-A1E	10	2.0	0.0318	320	0.075	40	100
	SGMMV-A1A							
	SGMMV-A2E	20	2.6	0.0637	221.5	0.108	40	100
	SGMMV-A2A							
	SGMMV-A3E	30	2.6	0.0955	221.5	0.108	40	100
	SGMMV-A3A							

Notes: 1 The holding brake is only used to hold the load and cannot be used to stop the servomotor.
 2 The holding brake open time and holding brake operation time vary depending on which discharge circuit is used. Make sure holding brake open time and holding brake operation time are correct for your servomotor.
 3 A 24-VDC power supply is not included.

● Overload Characteristics

The overload detection level is set under hot start conditions at a servomotor ambient temperature of 40°C.

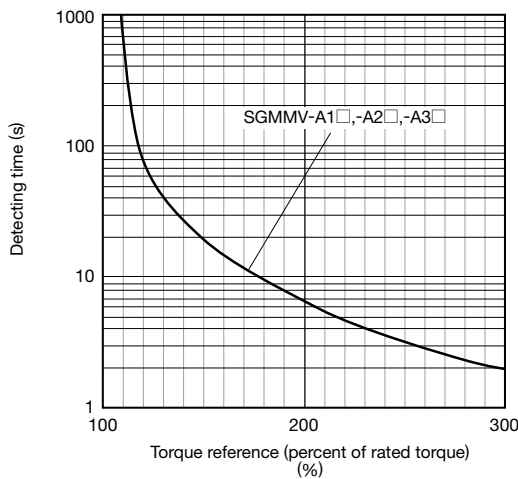
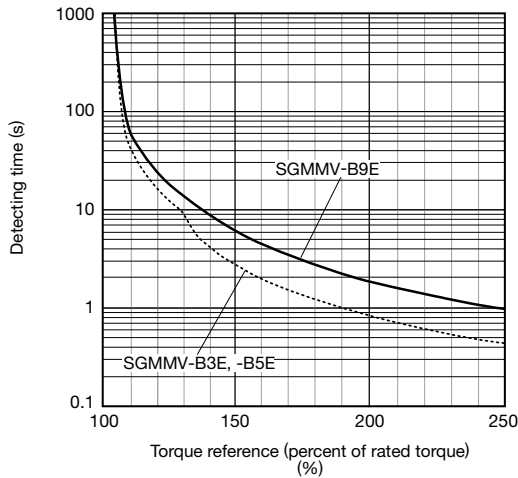

Note: Overload characteristics shown above do not guarantee continuous duty of 100% or more output. Use a servomotor with effective torque within the continuous duty zone of Torque-Motor Speed Characteristics.

Ratings and Specifications

● Allowable Load Moment of Inertia at the Motor Shaft

The rotor moment of inertia ratio is the value for a servomotor without a gear and a holding brake.

Servomotor Model		Servomotor Rated Output	Allowable Load Moment of Inertia (Rotor Moment of Inertia Ratio)
SGMMV-	B3	3.3 W	30 times
	B5	5.5 W	
	B9	11 W	
	A1	10 W	
	A2	20 W	
	A3	30 W	

● Load Moment of Inertia

The larger the load moment of inertia, the worse the movement response.

The allowable load moment of inertia (J_L) depends on the motor capacity, as shown above. This value is provided strictly as a guideline and results may vary depending on servomotor drive conditions.

Use the AC servo drive capacity selection program SigmaJunmaSize+ to check the operation conditions. The program can be downloaded for free from our web site (<http://www.e-mechatronics.com/>).

An overvoltage alarm (A.400) is likely to occur during deceleration if the load moment of inertia exceeds the allowable load moment of inertia. Take one of the following steps if this occurs.

- Reduce the torque limit.
- Reduce the deceleration rate.
- Reduce the maximum speed.

● Allowable Radial and Thrust Loads

Design the mechanical system so thrust and radial loads applied to the servomotor shaft end during operation fall within the ranges shown in the table.

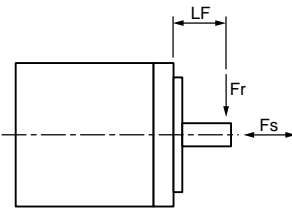
Servomotor Model		Allowable Radial Load (F_r) N	Allowable Thrust Load (F_s) N	LF mm	Reference Diagram
SGMMV-	B3	8	4	10	
	B5	8	4	10	
	B9	10	4	10	
	A1	34	14.5	16	
	A2	44	14.5	16	
	A3	44	14.5	16	

External Dimensions Units: mm

● Without Holding Brakes

(1) 3.3 to 11 W

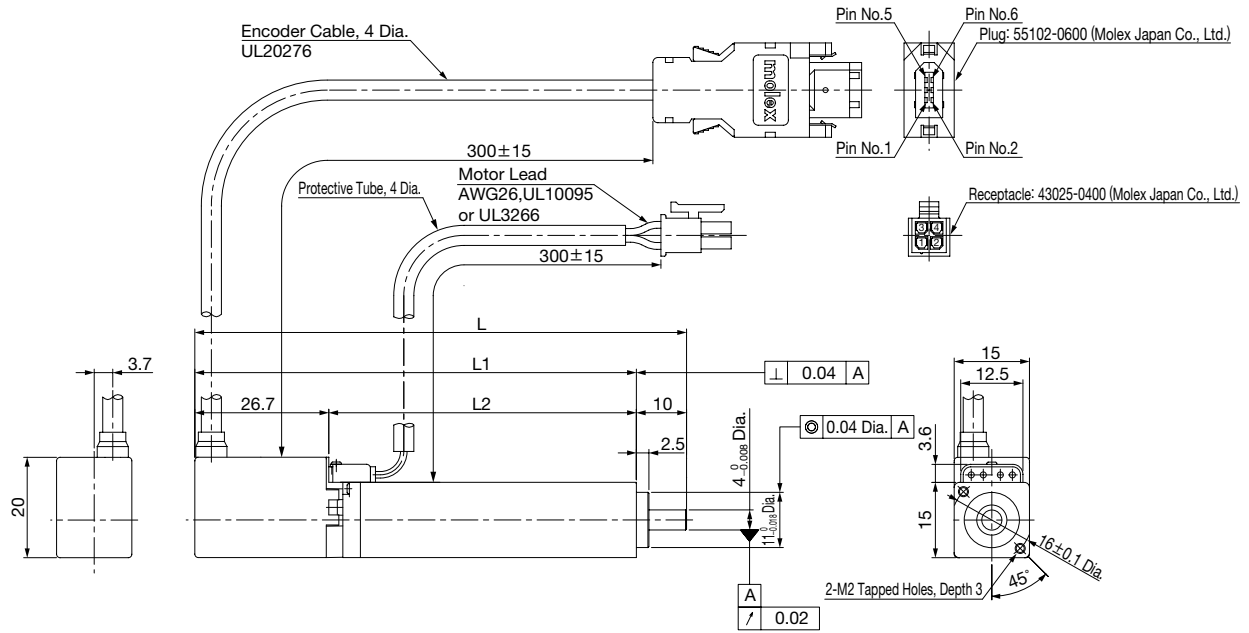

Model SGMMV-	L	L1	L2	Approx. Mass kg
B3E2A□1	58	48	21.3	0.055
B5E2A□1	64	54	27.3	0.06
B9E2A□1	98	88	61.3	0.1

<Shaft End>

● With a Flat Seat

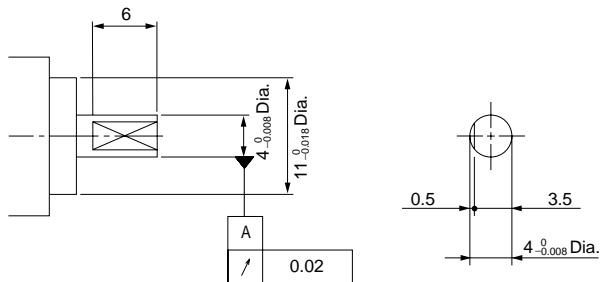

External Dimensions Units: mm

(2) 10 to 30 W

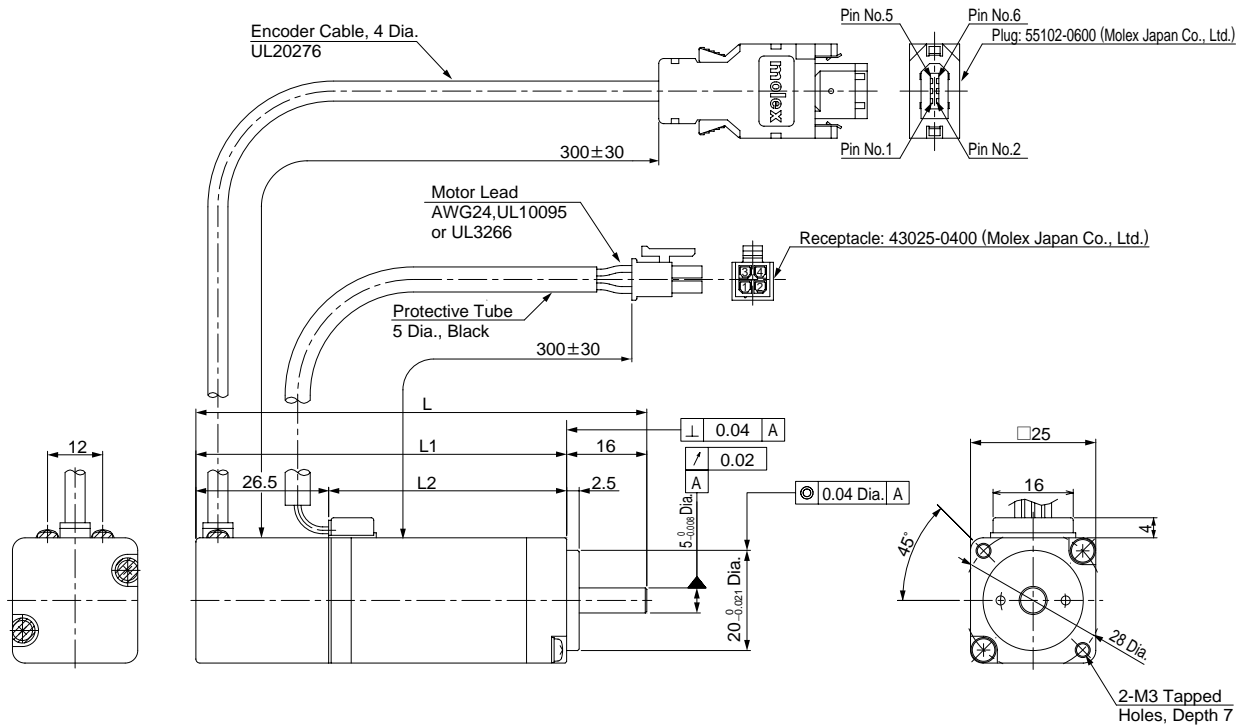

Model SGMMV-	L	L1	L2	Approx. Mass kg
A1□2A□1	70	54	27.5	0.13
A2□2A□1	80	64	37.5	0.17
A3□2A□1	90	74	47.5	0.21

<Shaft End>

● With a Flat Seat

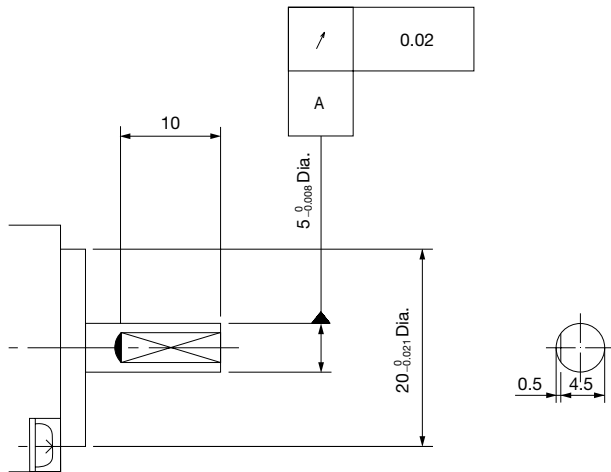

External Dimensions Units: mm

● With Holding Brakes

(1) 10 to 30 W

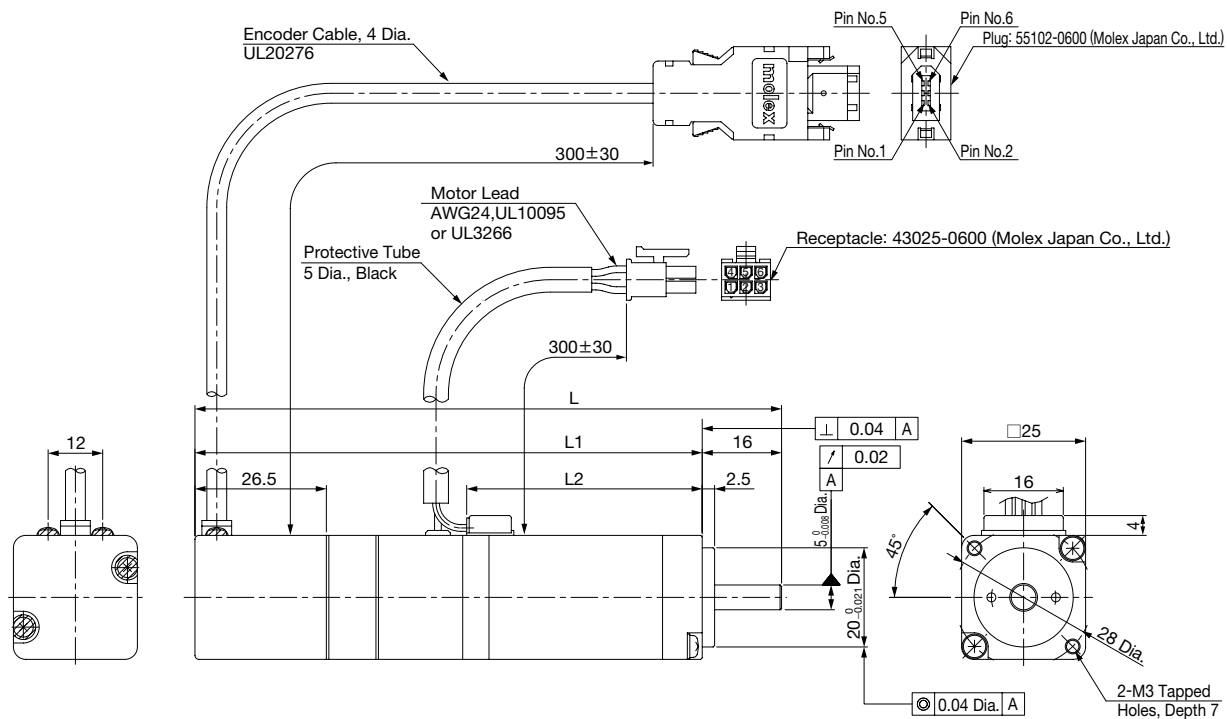

Model SGMMV-	L	L1	L2	Approx. Mass kg
A1□2A□C	94.5	78.5	27.5	0.215
A2□2A□C	108.5	92.5	37.5	0.27
A3□2A□C	118.5	102.5	47.5	0.31

<Shaft End>

● With a Flat Seat

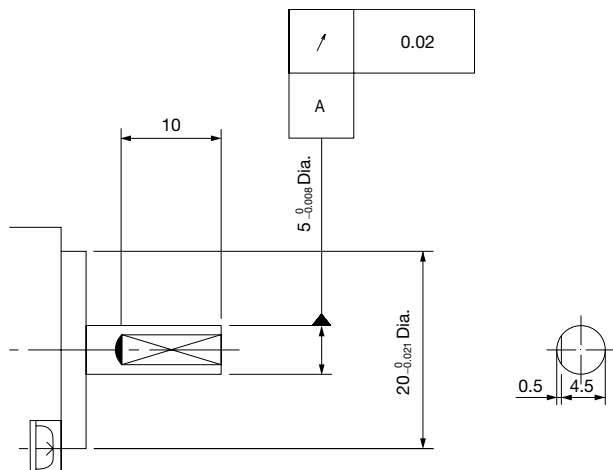

Selecting Cables for SERVOPACKs with DC Power Input

● Examples of Cable Connections

● Standard Wiring (Max. encoder cable length: 20 m)

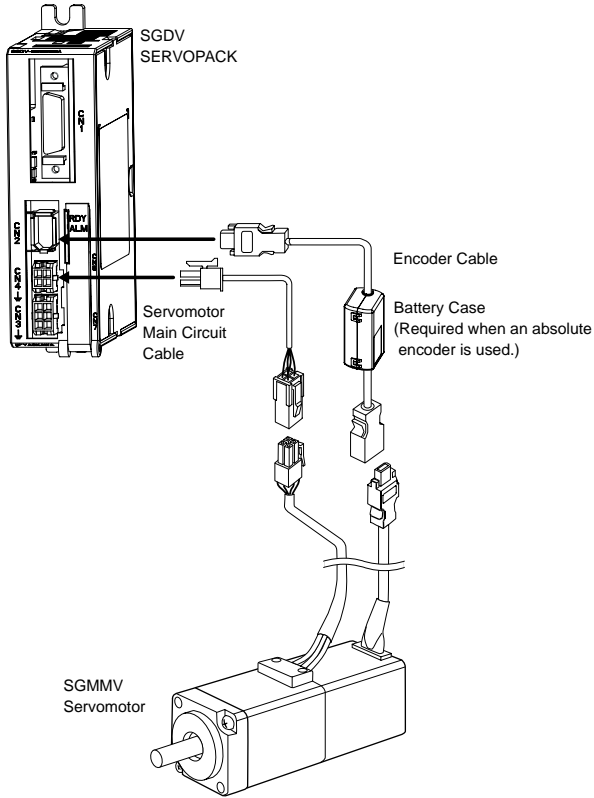

● Encoder Cable Extension from 30 to 50 m

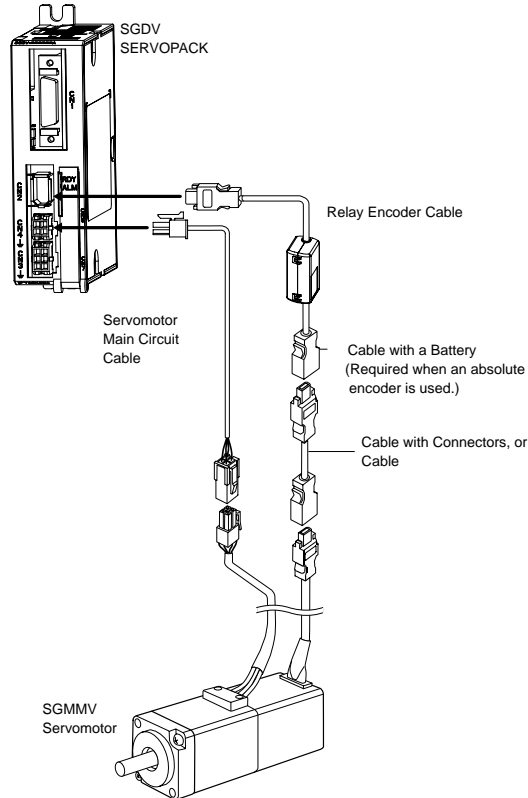

⚠ CAUTION

- Separate the servomotor main circuit cable wiring from the I/O signal cable and encoder cable at least 30 cm, and do not bundle or run them in the same duct.
- When the cable length exceeds 20 m, be sure to use a relay encoder cable.
- If the main circuit cable for the servomotor causes the line-to-line voltage to drop, the intermittent duty zone of the torque-motor speed characteristics may become smaller.

● Servomotor Main Circuit Cable

Name	Length	Order No.		Specifications	Details
		Standard Type	Flexible Type*		
For Servomotor without Holding Brakes	3 m	JZSP-CF1M00-03-E	JZSP-CF1M20-03-E		(1)
	5 m	JZSP-CF1M00-05-E	JZSP-CF1M20-05-E		
	10 m	JZSP-CF1M00-10-E	JZSP-CF1M20-10-E		
	15 m	JZSP-CF1M00-15-E	JZSP-CF1M20-15-E		
	20 m	JZSP-CF1M00-20-E	JZSP-CF1M20-20-E		
	30 m	JZSP-CF1M00-30-E	JZSP-CF1M20-30-E		
	40 m	JZSP-CF1M00-40-E	JZSP-CF1M20-40-E		
	50 m	JZSP-CF1M00-50-E	JZSP-CF1M20-50-E		
For Servomotor with Holding Brakes	3 m	JZSP-CF1M10-03-E	JZSP-CF1M30-03-E		(2)
	5 m	JZSP-CF1M10-05-E	JZSP-CF1M30-05-E		
	10 m	JZSP-CF1M10-10-E	JZSP-CF1M30-10-E		
	15 m	JZSP-CF1M10-15-E	JZSP-CF1M30-15-E		
	20 m	JZSP-CF1M10-20-E	JZSP-CF1M30-20-E		
	30 m	JZSP-CF1M10-30-E	JZSP-CF1M30-30-E		
	40 m	JZSP-CF1M10-40-E	JZSP-CF1M30-40-E		
	50 m	JZSP-CF1M10-50-E	JZSP-CF1M30-50-E		

*: Use flexible cables for movable sections such as robot arms.

Selecting Cables for SERVOPACKs with DC Power Input

(1) Wiring Specifications for Servomotors without Holding Brakes

SERVOPACK End		Servomotor End	
Pin No.	Signal	Signal	Pin No.
1	Phase U	Phase U	1
2	Phase V	Phase V	2
3	Phase W	Phase W	3
4	FG	FG	4

(2) Wiring Specifications for Servomotor with Holding Brakes

SERVOPACK End		Servomotor End	
Pin No.	Signal	Signal	Pin No.
1	Phase U	Phase U	1
2	Phase V	Phase V	2
3	Phase W	Phase W	3
4	FG	FG	4
Ring terminal	Brake	Brake	5
Ring terminal	Brake	Brake	6

Note: No polarity for connection to a holding brake.

● Encoder Cables (Length: 20 m or less)

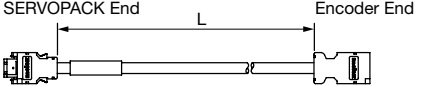
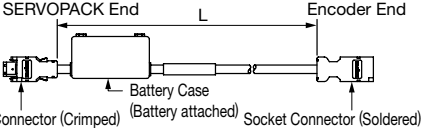
Name	Length	Order No.		Specifications	Details
		Standard Type	Flexible Type ^{*1}		
Cable with Connectors (For Incremental Encoder)	3 m	JZSP-CMP00-03-E	JZSP-CMP10-03-E	 SERVOPACK End Encoder End Connector (Crimped) Socket Connector (Soldered) (Molex Japan Co., Ltd.) (Molex Japan Co., Ltd.)	(1)
	5 m	JZSP-CMP00-05-E	JZSP-CMP10-05-E		
	10 m	JZSP-CMP00-10-E	JZSP-CMP10-10-E		
	15 m	JZSP-CMP00-15-E	JZSP-CMP10-15-E		
	20 m	JZSP-CMP00-20-E	JZSP-CMP10-20-E		
Cable with Connectors ^{*2} (For Absolute Encoder, with a Battery Case)	3 m	JZSP-CSP19-03-E	JZSP-CSP29-03-E	 SERVOPACK End Encoder End Connector (Crimped) Socket Connector (Soldered) (Molex Japan Co., Ltd.) (Molex Japan Co., Ltd.) Battery Case (Battery attached)	(2)
	5 m	JZSP-CSP19-05-E	JZSP-CSP29-05-E		
	10 m	JZSP-CSP19-10-E	JZSP-CSP29-10-E		
	15 m	JZSP-CSP19-15-E	JZSP-CSP29-15-E		
	20 m	JZSP-CSP19-20-E	JZSP-CSP29-20-E		
SERVOPACK-end Connector Kit		JZSP-CMP9-1-E		Soldered	(3)
Encoder-end Connector Kit		JZSP-CMP9-2-E		Soldered	
Cables	5 m	JZSP-CMP09-05-E	JZSP-CSP39-05-E	20 m Max.	(4)
	10 m	JZSP-CMP09-10-E	JZSP-CSP39-10-E		
	15 m	JZSP-CMP09-15-E	JZSP-CSP39-15-E		
	20 m	JZSP-CMP09-20-E	JZSP-CSP39-20-E		

*1: Use flexible cables for movable sections such as robot arms.

*2: When the battery is connected to the host controller, no battery case is required. If so, use a cable for incremental encoders.

Selecting Cables for SERVOPACKs with DC Power Input

(1) Wiring Specifications for Cable with Connectors (For incremental encoder)

SERVOPACK End		Encoder (Servomotor) End		
Pin No.	Signal	Pin No.	Wire Color	
			Standard Type	Flexible Type
6	/PS	6	Light blue/white	Black/light blue
5	PS	5	Light blue	Red/light blue
4	BAT(-)	4	Orange/white	Black/pink
3	BAT(+)	3	Orange	Red/pink
2	PG 0V	2	Black	Green
1	PG 5V	1	Red	Orange
Shell	FG	Shell	FG	FG

(2) Wiring Specifications for Cable with Connectors (For absolute encoder, with a battery case)

SERVOPACK End		Encoder (Servomotor) End		
Pin No.	Signal	Pin No.	Wire Color	
			Standard Type	Flexible Type
6	/PS	6	Light blue/white	Black/pink
5	PS	5	Light blue	Red/pink
4	BAT(-)	4	Orange/white	Black/light blue
3	BAT(+)	3	Orange	Red/light blue
2	PG 0V	2	Black	Green
1	PG 5V	1	Red	Orange
Shell	FG	Shell	FG	FG

Battery Case	
Pin No.	Signal
2	BAT(-)
1	BAT(+)

(3) SERVOPACK-end/Encoder-end Connector Kit Specifications

Items	SERVOPACK-end Connector Kit	Encoder-end Connector Kit
Order No.	JZSP-CMP9-1-E (Cables are not included.)	JZSP-CMP9-2-E (Cables are not included.)
Manufacturer	Molex Japan Co., Ltd.	Molex Japan Co., Ltd.
Specifications	55100-0670 (soldered) Product Specification: PS-54280	54280-0609 (soldered) Product Specification: PS-54280
External Dimensions mm		

Selecting Cables for SERVOPACKs with DC Power Input

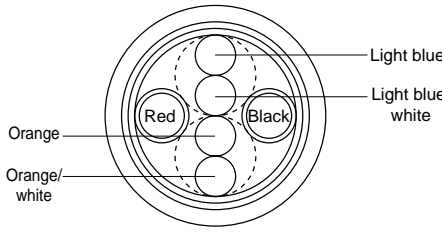
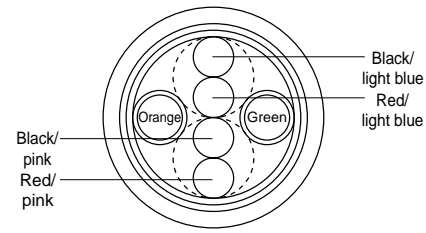

(4) Cable Specifications

Items	Standard Type	Flexible Type
Order No.*	JZSP-CMP09-□□-E	JZSP-CSP39-□□-E
Cable Length	20 m max.	
Specifications	UL20276 (Rating temperature: 80°C) AWG22X2C+AWG24X2P AWG22 (0.33 mm ²) Outer diameter of insulating sheath: 1.15 dia. mm AWG24 (0.20 mm ²) Outer diameter of insulating sheath: 1.09 dia. mm	UL20276 (Rating temperature: 80°C) AWG22X2C+AWG24X2P AWG22 (0.33 mm ²) Outer diameter of insulating sheath: 1.35 dia. mm AWG24 (0.20 mm ²) Outer diameter of insulating sheath: 1.21 dia. mm
Finished Dimensions	6.5 dia. mm	6.8 dia. mm
Internal Configuration and Lead Color		
Yaskawa Standards Specifications (Standard Length)	Cable length: 5 m, 10 m, 15 m, 20 m	

*: Specify the cable length in □□ of order no.
 Example: JZSP-CMP09-05-E (5 m)

Selecting Cables for SERVOPACKs with DC Power Input

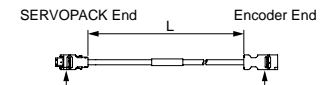
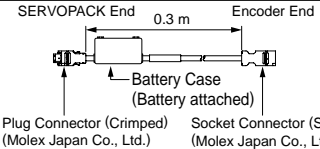
● Relay Encoder Cables (For extending from 30 to 50 m)

Name	Length	Order No. Standard Type	Specifications	Details
① Cable with Connectors (For incremental and absolute encoder)	30 m	JZSP-UCMP00-30-E		(1)
	40 m	JZSP-UCMP00-40-E		
	50 m	JZSP-UCMP00-50-E		
② Cable with a Battery Case (Required when an absolute encoder is used*)	0.3 m	JZSP-CSP12-E		(2)
③ Cables	30 m	JZSP-CMP19-30-E		(3)
	40 m	JZSP-CMP19-40-E		
	50 m	JZSP-CMP19-50-E		

*: Not required when connecting a battery to the host controller.

(1) Wiring Specifications for Cable with Connectors

SERVOPACK End		Encoder (Servomotor) End	
Pin No.	Signal	Pin No.	Wire Color
6	/PS	6	Light blue/white
5	PS	5	Light blue
4	BAT (-)	4	Orange/white
3	BAT (+)	3	Orange
2	PG 0V	2	Black
1	PG 5V	1	Red
Shell	FG	Shell	FG



(2) Wiring Specifications for Cable with a Battery Case

SERVOPACK End		Encoder (Servomotor) End	
Pin No.	Signal	Pin No.	Wire Color
6	/PS	6	Light blue/white
5	PS	5	Light blue
4	BAT (-)	4	Orange/white
3	BAT (+)	3	Orange
2	PG 0V	2	Black
1	PG 5V	1	Red
Shell	FG	Shell	FG

Battery Case	
Pin No.	Signal
2	BAT (-)
1	BAT (+)

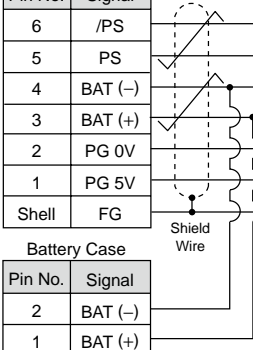

(3) Cable Specifications

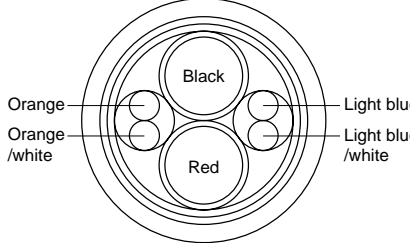
Item	Standard Type
Order No.*	JZSP-CMP19-□□-E
Cable Length	50 m max.
Specifications	UL20276 (Rating temperature: 80°C) AWG16x2C+AWG26x2P AWG16 (1.31 mm ²) Outer diameter of insulating sheath: 2.0 dia. mm AWG26 (0.13 mm ²) Outer diameter of insulating sheath: 0.91 dia. mm
Finished Dimensions	6.8 dia. mm
Internal Configuration and Lead Colors	
Yaskawa Standard Specifications (Standard Length)	Cable length: 30 m, 40 m, 50 m

*: Specify the cable length in □□ of order no.
Example: JZSP-CMP19-30-E (30 m)

Selecting Cables for SERVOPACKs with AC Power Input

● Examples of Cable Connections

● Standard Wiring (Max. encoder cable length: 20 m)

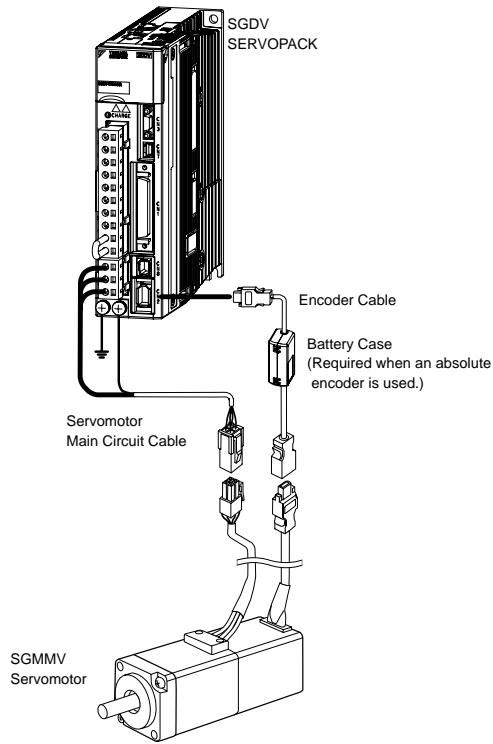

● Encoder Cable Extension from 30 to 50 m

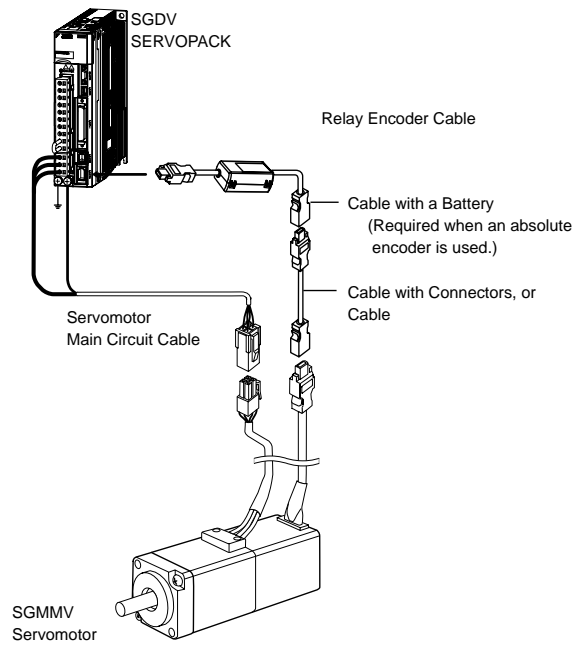

⚠ CAUTION

- Separate the servomotor main circuit cable wiring from the I/O signal cable and encoder cable at least 30 cm, and do not bundle or run them in the same duct.
- When the cable length exceeds 20 m, be sure to use a relay encoder cable.
- When the main circuit cable length exceeds 20 m, note that the intermittent duty zone of the Torque-Motor Speed Characteristics will shrink as the line-to-line voltage drops.

● Servomotor Main Circuit Cable

Name	Length	Order No.		Specifications	Details
		Standard Type	Flexible Type*		
For Servomotor without Holding Brakes	3 m	JZSP-CF2M00-03-E	JZSP-CF2M20-03-E		(1)
	5 m	JZSP-CF2M00-05-E	JZSP-CF2M20-05-E		
	10 m	JZSP-CF2M00-10-E	JZSP-CF2M20-10-E		
	15 m	JZSP-CF2M00-15-E	JZSP-CF2M20-15-E		
	20 m	JZSP-CF2M00-20-E	JZSP-CF2M20-20-E		
	30 m	JZSP-CF2M00-30-E	JZSP-CF2M20-30-E		
	40 m	JZSP-CF2M00-40-E	JZSP-CF2M20-40-E		
For Servomotor with Holding Brakes	3 m	JZSP-CF2M03-03-E	JZSP-CF2M23-03-E		(2)
	5 m	JZSP-CF2M03-05-E	JZSP-CF2M23-05-E		
	10 m	JZSP-CF2M03-10-E	JZSP-CF2M23-10-E		
	15 m	JZSP-CF2M03-15-E	JZSP-CF2M23-15-E		
	20 m	JZSP-CF2M03-20-E	JZSP-CF2M23-20-E		
	30 m	JZSP-CF2M03-30-E	JZSP-CF2M23-30-E		
	40 m	JZSP-CF2M03-40-E	JZSP-CF2M23-40-E		
50 m	JZSP-CF2M03-50-E	JZSP-CF2M23-50-E			

*: Use flexible cables for movable sections such as robot arms.

Selecting Cables for SERVOPACKs with AC Power Input

(1) Wiring Specifications for Servomotors without Holding Brakes



SERVOPACK-end Leads		Servomotor-end Connector	
Wire Color	Signal	Signal	Pin No.
Red	Phase U	Phase U	1
White	Phase V	Phase V	2
Blue	Phase W	Phase W	3
Green/yellow	FG	FG	4

(2) Wiring Specifications for Servomotor with Holding Brakes

SERVOPACK-end Leads		Servomotor-end Connector	
Wire Color	Signal	Signal	Pin No.
Red	Phase U	Phase U	1
White	Phase V	Phase V	2
Blue	Phase W	Phase W	3
Green/yellow	FG	FG	4
Black	Brake	Brake	5
Black	Brake	Brake	6

Note: No polarity for connection to a holding brake.

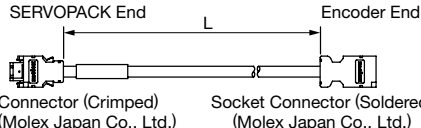
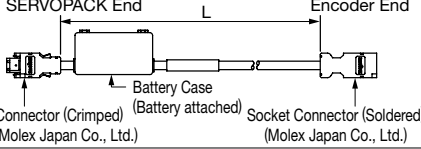
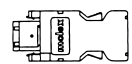
● Encoder Cables (Length: 20 m or less)

Name	Length	Order No.		Specifications	Details
		Standard Type	Flexible Type ^{*1}		
Cable with Connectors (For Incremental Encoder)	3 m	JZSP-CMP00-03-E	JZSP-CMP10-03-E		(1)
	5 m	JZSP-CMP00-05-E	JZSP-CMP10-05-E		
	10 m	JZSP-CMP00-10-E	JZSP-CMP10-10-E		
	15 m	JZSP-CMP00-15-E	JZSP-CMP10-15-E		
	20 m	JZSP-CMP00-20-E	JZSP-CMP10-20-E		
Cable with Connectors ^{*2} (For Absolute Encoder, with a Battery Case)	3 m	JZSP-CSP19-03-E	JZSP-CSP29-03-E		(2)
	5 m	JZSP-CSP19-05-E	JZSP-CSP29-05-E		
	10 m	JZSP-CSP19-10-E	JZSP-CSP29-10-E		
	15 m	JZSP-CSP19-15-E	JZSP-CSP29-15-E		
	20 m	JZSP-CSP19-20-E	JZSP-CSP29-20-E		
SERVOPACK-end Connector Kit		JZSP-CMP9-1-E		Soldered 	(3)
Encoder-end Connector Kit		JZSP-CMP9-2-E		Soldered 	
Cables	5 m	JZSP-CMP09-05-E	JZSP-CSP39-05-E	20 m Max. 	(4)
	10 m	JZSP-CMP09-10-E	JZSP-CSP39-10-E		
	15 m	JZSP-CMP09-15-E	JZSP-CSP39-15-E		
	20 m	JZSP-CMP09-20-E	JZSP-CSP39-20-E		

*1: Use flexible cables for movable sections such as robot arms.

*2: When the battery is connected to the host controller, no battery case is required. If so, use a cable for incremental encoders.

Selecting Cables for SERVOPACKs with AC Power Input

(1) Wiring Specifications for Cable with Connectors (For incremental encoder)

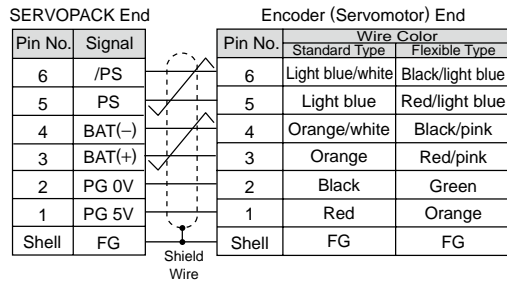

(2) Wiring Specifications for Cable with Connectors (For absolute encoder, with a battery case)

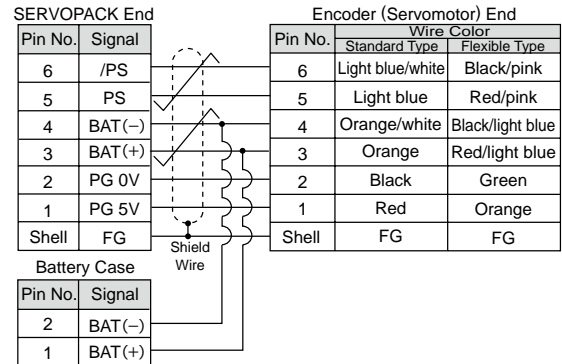

(3) SERVOPACK-end/Encoder-end Connector Kit Specifications

Items	SERVOPACK-end Connector Kit	Encoder-end Connector Kit
Order No.	JZSP-CMP9-1-E (Cables are not included.)	JZSP-CMP9-2-E (Cables are not included.)
Manufacturer	Molex Japan Co., Ltd.	Molex Japan Co., Ltd.
Specifications	55100-0670 (soldered) Product Specification: PS-54280	54280-0609 (soldered) Product Specification: PS-54280
External Dimensions mm		

Selecting Cables for SERVOPACKs with AC Power Input

(4) Cable Specifications

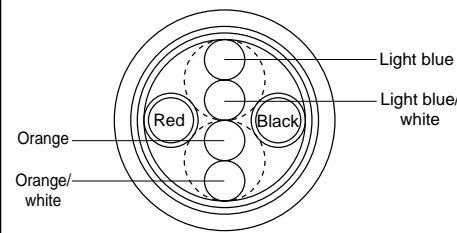
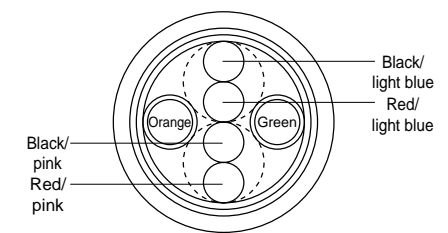
Items	Standard Type	Flexible Type
Order No.*	JZSP-CMP09-□□-E	JZSP-CSP39-□□-E
Cable Length	20 m max.	
Specifications	UL20276 (Rating temperature: 80°C) AWG22x2C+AWG24x2P AWG22 (0.33 mm ²) Outer diameter of insulating sheath: 1.15 dia. mm AWG24 (0.20 mm ²) Outer diameter of insulating sheath: 1.09 dia. mm	UL20276 (Rating temperature: 80°C) AWG22x2C+AWG24x2P AWG22 (0.33 mm ²) Outer diameter of insulating sheath: 1.35 dia. mm AWG24 (0.20 mm ²) Outer diameter of insulating sheath: 1.21 dia. mm
Finished Dimensions	6.5 dia. mm	6.8 dia. mm
Internal Configuration and Lead Color		
Yaskawa Standards Specifications (Standard Length)	Cable length: 5 m, 10 m, 15 m, 20 m	

*: Specify the cable length in □□ of order no.
 Example: JZSP-CMP09-05-E (5 m)

Selecting Cables for SERVOPACKs with AC Power Input

● Relay Encoder Cables (For extending from 30 to 50 m)

Name	Length	Order No. Standard Type	Specifications	Details
<input type="checkbox"/> Cable with Connectors (For incremental and absolute encoder)	30 m	JZSP-UCMP00-30-E		(1)
	40 m	JZSP-UCMP00-40-E		
	50 m	JZSP-UCMP00-50-E		
<input type="checkbox"/> Cable with a Battery Case (Required when an absolute encoder is used*)	0.3 m	JZSP-CSP12-E		(2)
<input type="checkbox"/> Cables	30 m	JZSP-CMP19-30-E		(3)
	40 m	JZSP-CMP19-40-E		
	50 m	JZSP-CMP19-50-E		

*: Not required when connecting a battery to the host controller.

(1) Wiring Specifications for Cable with Connectors

SERVOPACK End		Encoder (Servomotor) End	
Pin No.	Signal	Pin No.	Wire Color
6	/PS	6	Light blue/white
5	PS	5	Light blue
4	BAT (-)	4	Orange/white
3	BAT (+)	3	Orange
2	PG 0V	2	Black
1	PG 5V	1	Red
Shell	FG	Shell	FG

(2) Wiring Specifications for Cable with a Battery Case

SERVOPACK End		Encoder (Servomotor) End	
Pin No.	Signal	Pin No.	Wire Color
6	/PS	6	Light blue/white
5	PS	5	Light blue
4	BAT (-)	4	Orange/white
3	BAT (+)	3	Orange
2	PG 0V	2	Black
1	PG 5V	1	Red
Shell	FG	Shell	FG

Battery Case	
Pin No.	Signal
2	BAT (-)
1	BAT (+)

(3) Cable Specifications

Item	Standard Type
Order No.*	JZSP-CMP19-□□-E
Cable Length	50 m max.
Specifications	UL20276 (Rating temperature: 80°C) AWG16x2C+AWG26x2P AWG16 (1.31 mm ²) Outer diameter of insulating sheath: 2.0 dia. mm AWG26 (0.13 mm ²) Outer diameter of insulating sheath: 0.91 dia. mm
Finished Dimensions	6.8 dia. mm
Internal Configuration and Lead Colors	
Yaskawa Standard Specifications (Standard Length)	Cable length: 30 m, 40 m, 50 m

*: Specify the cable length in □□ of order no.
 Example: JZSP-CMP19-30-E (30 m)

SGMMV