

Linear Slides

Σ -Trac

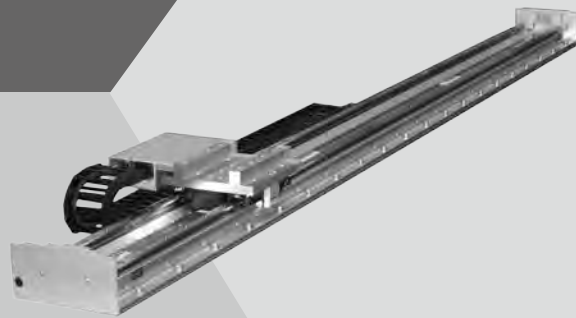

Model Designation

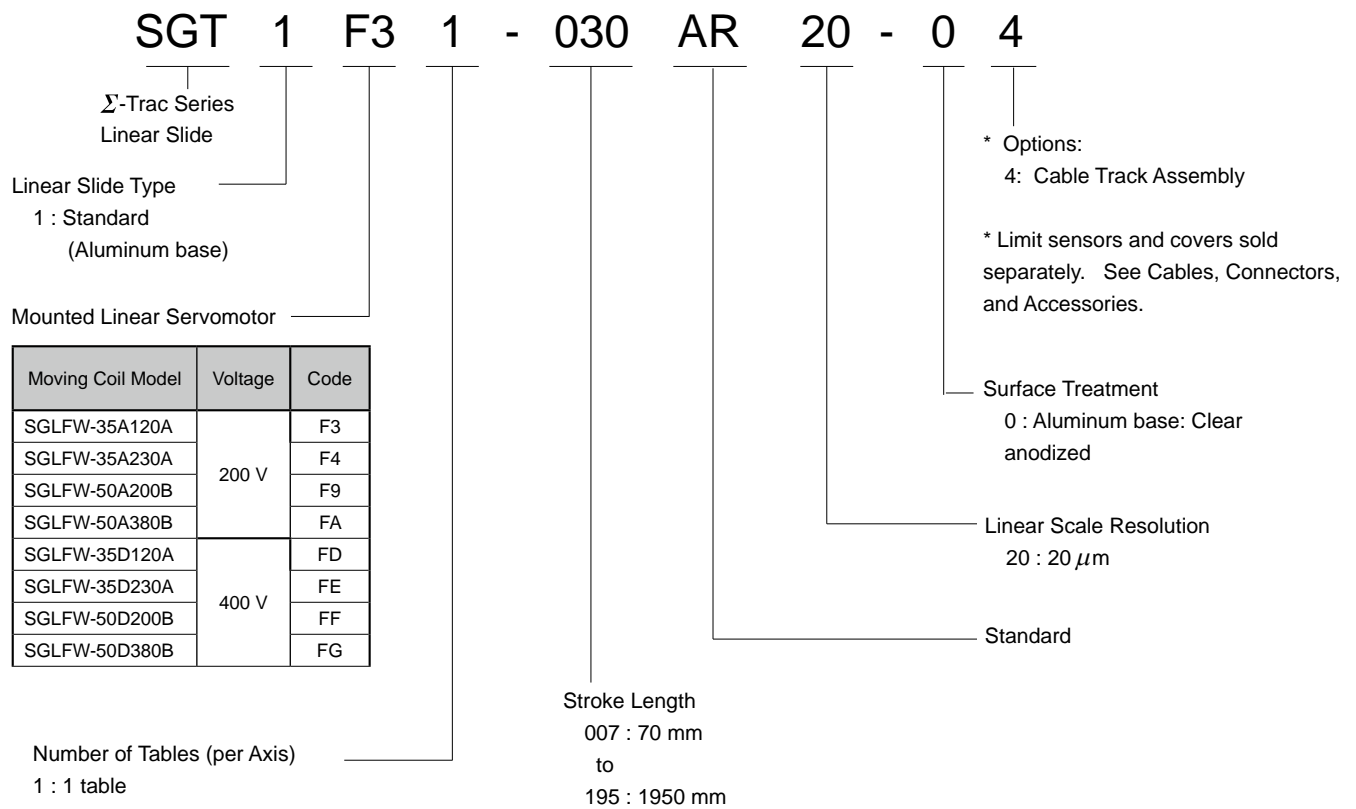

Features

- Factory assembled, fully integrated linear motor driven slide reduces machine design complexity and commissioning time.
- Automatic motor recognition by Yaskawa amplifiers eliminates need for user to input motor coil parameters.
- Long strokes and high-speed, high accuracy positioning.
- Large integrated cable carrier allows space for peripheral cables and hoses.
- Covers and accessories available as accessories (up to 1 m stroke).
- See www.yaskawa.com for "Quick Ship" program details.

Application Examples

- Pick and Place
- Precision Dispensing
- Vision Inspection
- Laser Cutting/Machining.
- Engraving
- Flat Panel Display Manufacture (LCD Substrate Handling)
- Industrial Laser and Ink Jet Printing
- Electronic Component Assembly
- Insertion Machines (Packaging)

Model Classification

● Force

SERVOPACK Model SGD-			Σ-Trac Series Linear Slides							
Single-phase 100 VAC	Three-phase 200 VAC	Three-phase 400 VAC	Model	Force	200 N	400 N	600 N	800 N	1000 N	1200 N
2R1F	1R6A	–	SGT1F31-□□□							
–	–	1R9D	SGT1FD1-□□□						Rated force	Peak force
–	3R8A	–	SGT1F41-□□□							
–	–	1R9D	SGT1FE1-□□□							
–	5R5A	–	SGT1F91-□□□							
–	–	3R5D	SGT1FF1-□□□							
–	120A	–	SGT1FA1-□□□							
–	–	5R4D	SGT1FG1-□□□							

● Stroke Length

Model	Stroke Length	500 mm	1000 mm	1500 mm	2000 mm
SGT1F31-□□□ SGT1FD1-□□□	80 mm				1950 mm
SGT1F41-□□□ SGT1FE1-□□□	180 mm				1830 mm
SGT1F91-□□□ SGT1FF1-□□□	70 mm				1830 mm
SGT1FA1-□□□ SGT1FG1-□□□	170 mm				1650 mm

SGT1F31, SGT1F41, SGT1FD1, and SGT1FE1 Linear Slides

● Ratings and Specifications

Time Rating: Continuous
 Insulation Resistance: 500 VDC, 10 MΩ min.
 Ambient Temperature: 0 to 40°C
 Excitation: Permanent magnet

Withstand Voltage: 1500 VAC for one minute
 Enclosure: Self-cooled
 Ambient Humidity: 20% to 80% (no condensation)
 Winding Insulation: Class A

Linear Slide Model ^{*1}		200 V Models		400 V Models	
		SGT1F31-□□□ AR20-04	SGT1F41-□□□ AR20-04	SGT1FD1-□□□ AR20-04	SGT1FE1-□□□ AR20-04
Mounted Linear Servomotor Model	SGLFW-	35A120AP	35A230AP	35D120AP	35D230AP
Applicable SERVOPACK Model	SGDV-	2R1F, 1R6A	3R8A	1R9A	1R9A
Mounted Serial Converter Unit Model	JZDP-	D008-019	D008-020	D008-211	D008-212
Rated Force	N	80	160	80	160
Peak Force	N	220	440	220	440
Force Constant	N / A _{rms}	62.4	62.4	136	136
Motor Constant	N / √W	14.4	20.4	14.2	20.1
Maximum Payload ^{*2, *3}	kg	30	70	30	70
Movable Member Mass	kg	4.3	6.6	4.3	6.6
Total Mass	kg	See Table 1	See Table 2	See Table 1	See Table 2
Effective Stroke	mm	on the next page.	on the next page.	on the next page.	on the next page.
Resolution	μm	0.078 (20 μm / 256)		0.078 (20 μm / 256)	
Repeatability ^{*4}	μm	±1.0	±1.0	±1.0	±1.0
Absolute Accuracy	μm	Consult factory		Consult factory	
Straightness and Flatness	μm	Consult factory		Consult factory	

*1: Squares (□□□) are used to indicate the stroke length code shown in Tables 1 and 2.

*2: Values obtained when the acceleration is 4.9 m/s².

*3: Contact your Yaskawa representative if the expected payload exceeds the value indicated in the table.

*4: Values obtained when the ambient temperature is constant.

● Performance Curves

● Force - Speed

A : Continuous Duty Zone
B : Intermittent Duty Zone (Note)

(1) SGT1F31,
SGT1FD1

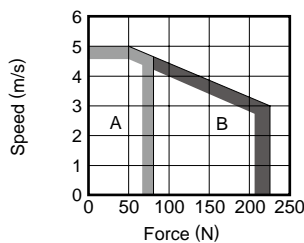

(2) SGT1F41,
SGT1FE1

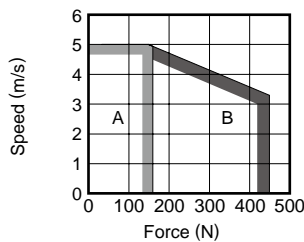

Note: When the effective force during intermittent duty is within the rated force, the servomotor can be used within the intermittent duty zone.

● Effective Force - Ambient Temperature ● Load Mass - Acceleration

When the sensor temperature is 50°C or less

Average speed (m/s) : 0 — 1 — 2 —

Note: Average speed = Total movement distance (m) / cycle time (s)

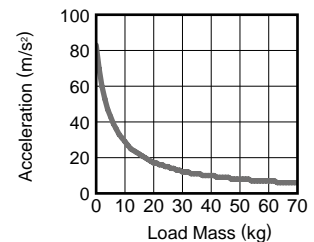
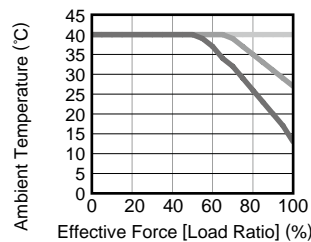
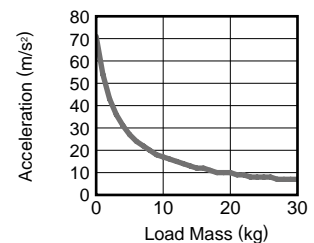

SGT1F31, SGT1F41, SGT1FD1, and SGT1FE1 Linear Slides Units: mm

● External Dimensions

(1) SGT1F31, SGT1FD1

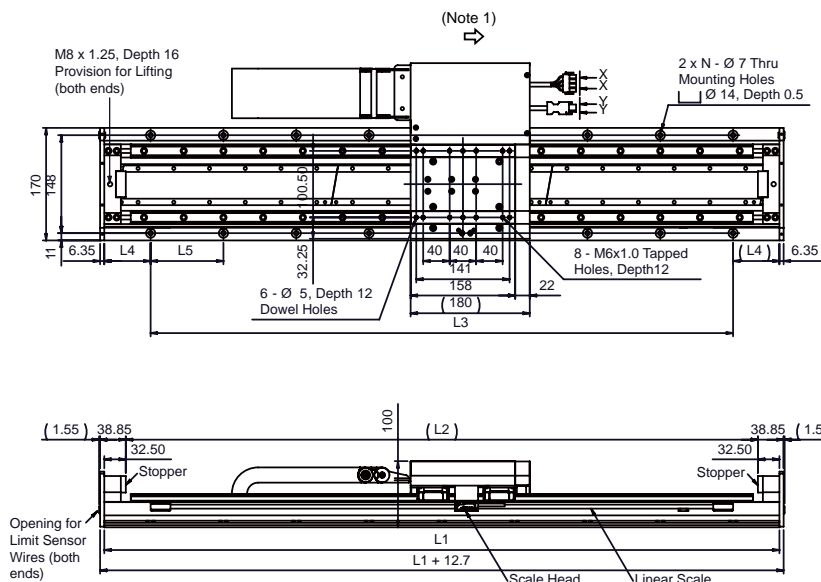

Table 1

Stroke		L1	L2	L3	L4	L5	N	Total Mass
Code	Length	mm	mm	mm	mm	mm		kg
008	80	360	295	270	45	90	4	10.4
030	300	580	515	440			5	14.4
041	410	690	625	550			6	16.3
052	520	800	735	660			7	18.2
063	630	910	845	770			8	20.0
074	740	1020	955	880			9	21.9
085	850	1130	1065	990			10	23.9
096	960	1240	1175	1100			11	26.0
107	1070	1350	1285	1210	70	110	12	27.8
118	1180	1460	1395	1320			13	29.8
129	1290	1570	1505	1430			14	31.6
140	1400	1680	1615	1540			15	33.5
151	1510	1790	1725	1650			16	35.6
162	1620	1900	1835	1760			17	37.5
173	1730	2010	1945	1870			18	39.4
184	1840	2120	2055	1980			19	41.3
195	1950	2230	2165	2090			20	43.2

(2) SGT1F41, SGT1FE1

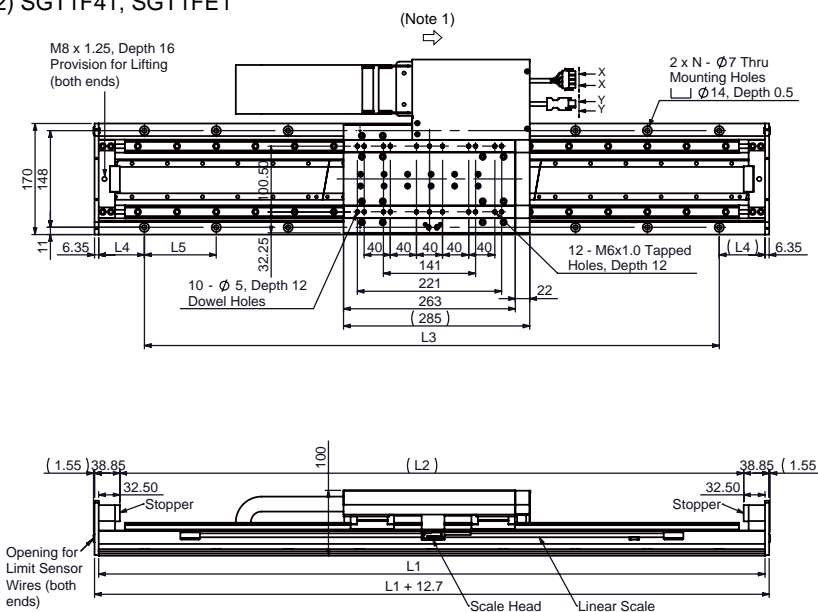

Table 2

Stroke		L1	L2	L3	L4	L5	N	Total Mass
Code	Length	mm	mm	mm	mm	mm		kg
018	180	580	515	440			5	16.5
029	290	690	625	550			6	18.5
040	400	800	735	660			7	20.4
051	510	910	845	770			8	22.2
062	620	1020	955	880			9	24.2
073	730	1130	1065	990			10	26.1
084	840	1240	1175	1100			11	28.6
095	950	1350	1285	1210	70	110	12	30.1
106	1060	1460	1395	1320			13	32.0
117	1170	1570	1505	1430			14	33.8
128	1280	1680	1615	1540			15	35.8
139	1390	1790	1725	1650			16	37.7
150	1500	1900	1835	1760			17	39.8
161	1610	2010	1945	1870			18	41.6
172	1720	2120	2055	1980			19	43.6
183	1830	2230	2165	2090			20	44.3

Notes: 1 The moving coil moves in the direction indicated by the arrow when current flows in the order of phase U, V, and W.
2 When installing the linear slide, the surface should be flat to the equivalent of a maximum discrepancy of 0.02/200 mm (reference value).

• Connector Specifications for the Σ-Trac Series Linear Slides (All Models)

View X-X

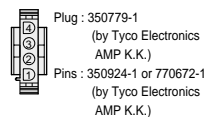

Pin No.	Signal
1	Phase-U output
2	Phase-V output
3	Phase-W output
4	FG

View Y-Y

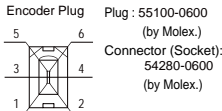

For Encoder Connection

Pin	Signal	Wire Color
1	PG 5V	Red
2	PG 0V	Black
3	-	-
4	-	-
5	Data +	Light Blue
6	Data -	White/Light Blue

Linear Slides

SGT1F91, SGT1FA1, SGT1FF1, and SGT1FG1 Linear Slides

● Ratings and Specifications

Time Rating: Continuous
 Insulation Resistance: 500 VDC, 10 MΩ min.
 Ambient Temperature: 0 to 40°C
 Excitation: Permanent magnet

Withstand Voltage: 1500 VAC for one minute
 Enclosure: Self-cooled
 Ambient Humidity: 20% to 80% (no condensation)
 Winding Insulation: Class A

Linear Slide Model ¹		200 V Models		400 V Models	
		SGT1F91-□□□ AR20-04	SGT1FA1-□□□ AR20-04	SGT1FF1-□□□ AR20-04	SGT1FG1-□□□ AR20-04
Mounted Linear Servomotor Model	SGLFW-	50A200BP	50A380BP	50D200BP	50D380BP
Applicable SERVOPACK Model	SGDV-	5R5A	120A	3R5D	5R4D
Applicable Serial Converter Unit Model	JZDP-	D008-181	D008-182	D008-189	D008-190
Rated Force	N	280	560	280	560
Peak Force	N	600	1200	600	1200
Force Constant	N / A _{rms}	60.2	60.2	134.7	134.7
Motor Constant	N / √W	34.3	48.5	34.4	47.2
Maximum Payload ^{2,3}	kg	100	215	100	215
Movable Member Mass	kg	8.5	14.5	8.5	14.5
Total Mass	kg	See Table 1	See Table 2	See Table 1	See Table 2
Effective Stroke	mm	on the next page.	on the next page.	on the next page.	on the next page.
Resolution	μm	0.078 (20 μm / 256)		0.078 (20 μm / 256)	
Repeatability ⁴	μm	±1.0		±1.0	
Absolute Accuracy	μm	Consult factory		Consult factory	
Straightness and Flatness	μm	Consult factory		Consult factory	

*1: Squares (□□□) are used to indicate the stroke length code shown in Tables 1.
 *2: Values obtained when the acceleration is 4.9 m/s².
 *3: Contact your Yaskawa representative if the expected payload exceeds the value indicated in the table.
 *4: Values obtained when the ambient temperature is constant.

● Performance Curves

● Force - Speed

A : Continuous Duty Zone
B : Intermittent Duty Zone (Note)

(1) SGT1F91,
SGT1FF1

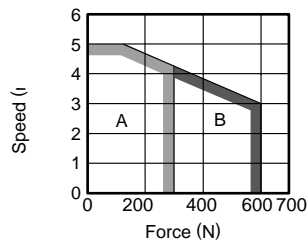

(2) SGT1FA1,
SGT1FG1

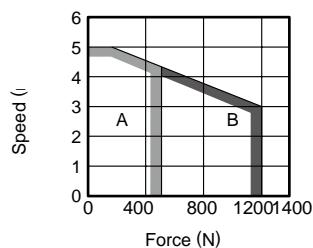

Note: When the effective force during intermittent duty is within the rated force, the servomotor can be used within the intermittent duty zone.

● Effective Force - Ambient Temperature ● Load Mass - Acceleration

When the sensor temperature is 50°C or less
 Average speed (m/s) : 0 — 1 — 2 —
 Note: Average speed = Total movement distance (m) / cycle time (s)

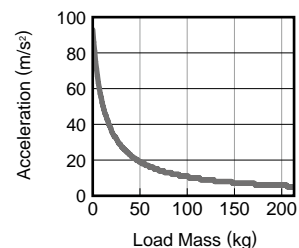
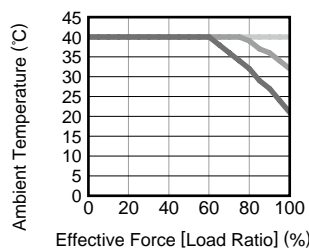
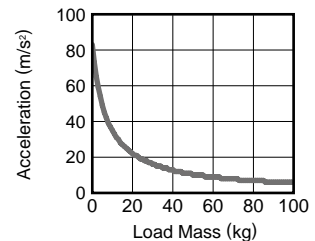
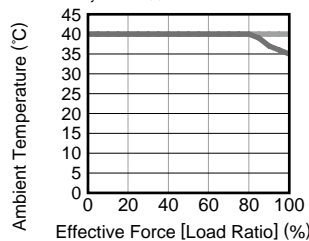

SGT1F91, SGT1FA1, SGT1FF1, and SGT1FG1 Linear Slides Units: mm

External Dimensions

(1) SGT1F91, SGT1FF1

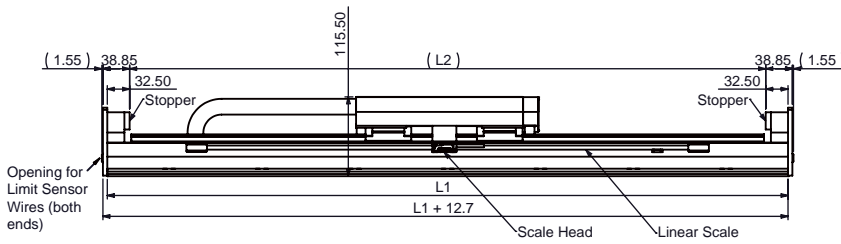
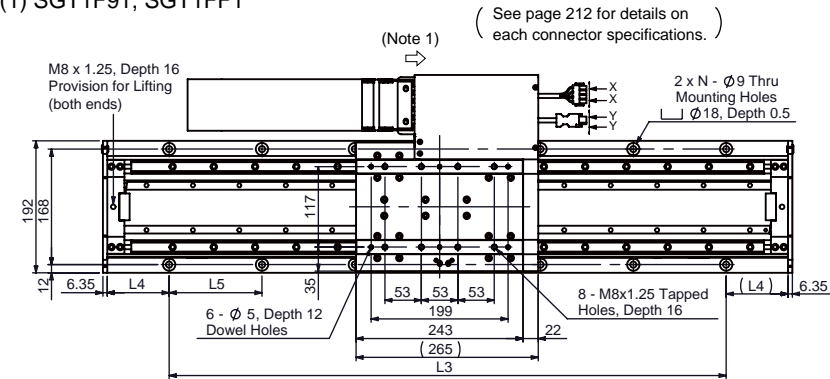
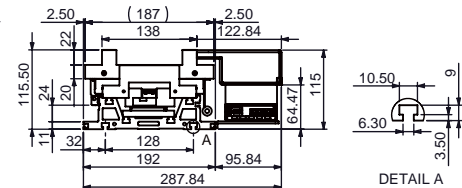

Table 1

Stroke Code	Length	L1 mm	L2 mm	L3 mm	L4 mm	L5 mm	N	Total Mass kg
007	70	440	375	300	70	100	4	17.3
035	350	720	655	540	90	135	5	22.8
048	480	850	785	675	87.5		6	25.6
062	620	990	925	810	90		7	28.4
075	750	1120	1055	945	87.5		8	31.0
089	890	1260	1195	1080	90		9	33.8
102	1020	1390	1325	1215	87.5		10	36.6
116	1160	1530	1465	1350	90		11	39.3
129	1290	1660	1595	1485	87.5		12	41.9
143	1430	1800	1735	1620	90		13	44.7
156	1560	1930	1865	1755	87.5		14	47.5
170	1700	2070	2005	1890	90		15	50.2
183	1830	2200	2135	2025	87.5		16	53.0



Note: Endplate removed in this view

(2) SGT1FA1, SGT1FG1

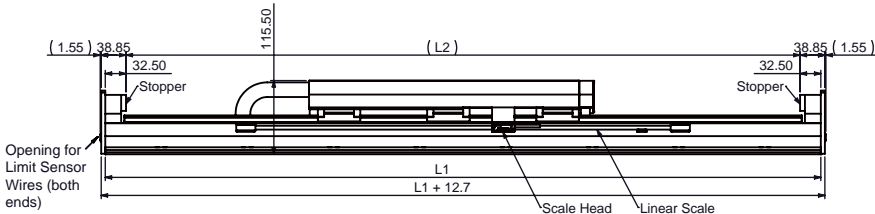
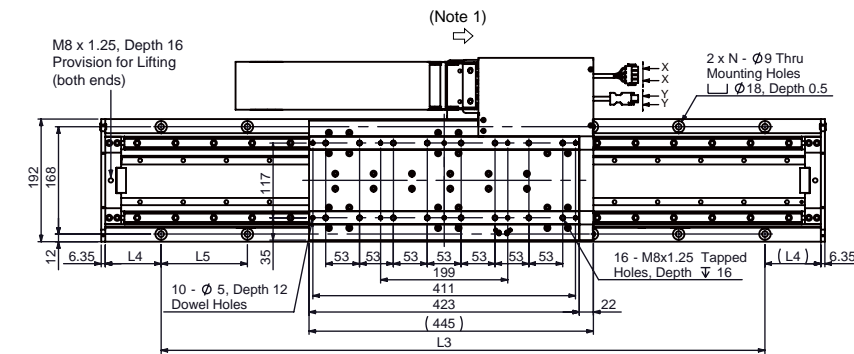
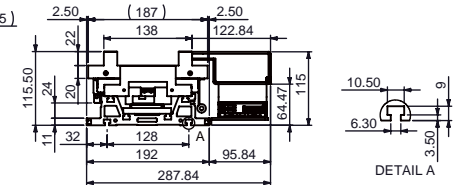

Table 2

Stroke Code	Length	L1 mm	L2 mm	L3 mm	L4 mm	L5 mm	N	Total Mass kg
017	170	720	655	540	90	135	5	28.7
030	300	850	785	675	87.5		6	31.6
044	440	990	925	810	90		7	34.4
057	570	1120	1055	945	87.5		8	37.0
071	710	1260	1195	1080	90		9	39.7
084	840	1390	1325	1215	87.5		10	42.6
098	980	1530	1465	1350	90		11	45.3
111	1110	1660	1595	1485	87.5		12	47.9
125	1250	1800	1735	1620	90		13	50.6
138	1380	1930	1865	1755	87.5		14	53.4
152	1520	2070	2005	1890	90		15	56.2
165	1650	2200	2135	2025	87.5		16	58.9



Note: Endplate removed in this view

Notes: 1 The moving coil moves in the direction indicated by the arrow when current flows in the order of phase U, V, and W.
2 When installing the linear Slide, the surface should be flat to the equivalent of a maximum discrepancy of 0.02/200 mm (reference value).

Selecting Cables, Connectors, and Accessories

● Connection diagrams

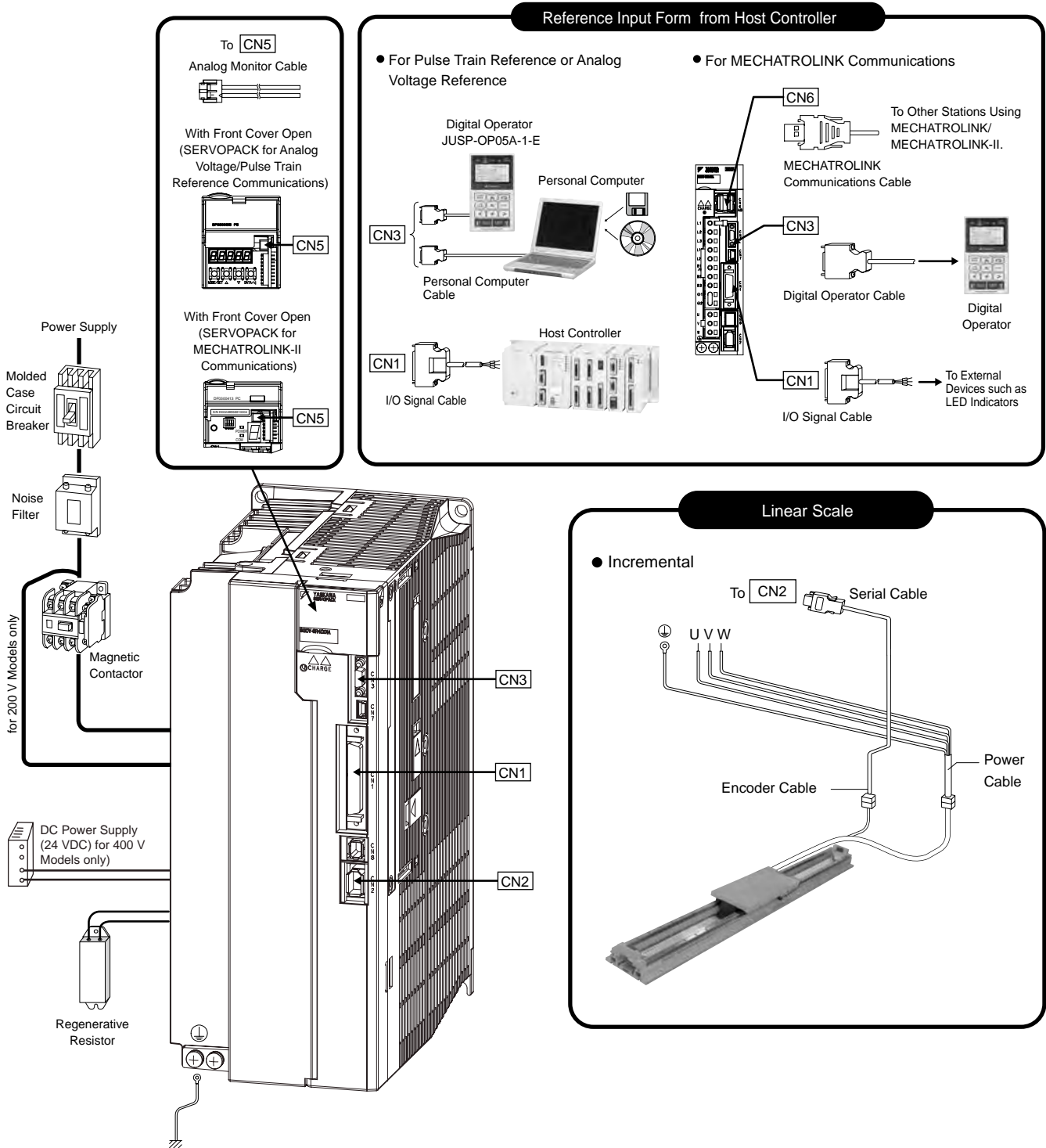

Selecting Cables, Connectors, and Accessories

● Applicable Cables and Connectors

Motor Type	Linear Scale Type	Servo Drive			Motor Cable	Linear Scale Connection Cables	Pulse-train or Analog Voltage Reference			
		Σ-Trac Series Model	SERVOPACK Model SGD V-			SERVOPACK ↔ Motor	[CN2] ↔ Encoder Cable	I/O Signal Connector [CN1]		
			Single-phase 100 V	Three-phase 200 V	Three-phase 400 V	Power Cable (Flexible Type)	Serial Cable (Flexible Type)	Connector Terminal Block Converter Unit	Cable with Loose Wires at One End	Connector Kit (CN1)
Moving Coil (MC)	Incremental	SGT1F31-□□□ AR20-04	2R1F,	-	-	JZSP-CLN11-□□	JZSP-CMP00-□□ (A) The numbers in the boxes(□□) indicate the cable length. 03 = 3 m 05 = 5 m 10 = 10 m 15 = 15 m 20 = 20 m	JZSP-TA50PG-E (with a 0.5 m cable)	JZSP-CS101-□-E The number in the box (□) indicates the cable length. 1 = 1 m 2 = 2 m 3 = 3 m	JZSP-CS19-1-E
		SGT1FD1-□□□ AR20-04	-	1R6A	-					
		SGT1F41-□□□ AR20-04	-	3R8A	-	JZSP-CLN11-□□				
		SGT1FE1-□□□ AR20-04	-	-	1R9D	JZSP-CLN21-□□				
		SGT1F91-□□□ AR20-04	-	5R5A	-	JZSP-CLN21-□□				
		SGT1FF1-□□□ AR20-04	-	-	3R5D	JZSP-CLN21-□□				
		SGT1FA1-□□□ AR20-04	-	120A	-	JZSP-CLN21-□□				
		SGT1FG1-□□□ AR20-04	-	-	5R4D	JZSP-CLN21-□□				

Motor Type	Linear Scale Type	Servo Drive			MECHATROLINK Communications			Cables for Setting Devices/Monitors	
		Σ-Trac Series Model	SERVOPACK Model SGD V-			I/O Signal Connector [CN1]		[CN3] ↔ Setting Devices	[CN5]
			Single-phase 100 V	Three-phase 200 V	Three-phase 400 V	Connector Terminal Block Converter Cable	Connector Kit (CN1)	MECHATROLINK Communications Connector [CN6A] or [CN6B]	Personal Computer Cable
Moving Coil (MC)	Incremental	SGT1F31-□□□ AR20-04	2R1F,	-	-	JZSP-TA26P-□-E □ → None = 0.5 m 1 = 1 m 2 = 2 m	MECHATROLINK communications cable: JEPMC-W6002-□□-E The numbers in the boxes(□□) indicate the cable length. A5 = 0.5 m 20 = 20 m 01 = 1 m 30 = 30 m 03 = 3 m 40 = 40 m 05 = 5 m 50 = 50 m 10 = 10 m MECHATROLINK terminator: JEPMC-W6022-E	JZDP-CMS02-E (2 m)	JZSP-CA01-E (1 m)
		SGT1FD1-□□□ AR20-04	-	1R6A	-				
		SGT1F41-□□□ AR20-04	-	3R8A	-				
		SGT1FE1-□□□ AR20-04	-	-	1R9D				
		SGT1F91-□□□ AR20-04	-	5R5A	-				
		SGT1FF1-□□□ AR20-04	-	-	3R5D				
		SGT1FA1-□□□ AR20-04	-	120A	-				
		SGT1FG1-□□□ AR20-04	-	-	5R4D				

● Applicable Accessories

Cover Kits: SGTA-CVR 3 - 030

Stroke Code for Motor Selected

Motor Code	
3	Covers for SGT1F31, SGT1FD1
4	Covers for SGT1F41, SGT1FE1
9	Covers for SGT1F91, SGT1FF1
A	Covers for SGT1FA1, SGT1FG1

Stroke Codes		Cover Length (mm)
SGT1F31 SGT1FD1	SGT1F41 SGT1FE1	
008	-	372.7
030	018	592.7
041	029	702.7
052	040	812.7
063	051	922.7
074	062	1032.7
085	073	1142.7
096	084	1252.7
107	095	1362.7

Stroke Codes		Cover Length (mm)
SGT1F91 SGT1FF1	SGT1FA1 SGT1FG1	
007	-	452.7
035	017	732.7
048	030	862.7
062	044	1002.7
075	057	1132.7
089	071	1272.7
102	084	1402.7

Note: Cover kit includes 1 top cover, 2 side covers, and all mounting hardware.

Limit Sensor Kits: SGTA-LSK□□□

Code	Description
PNO	PNP Normally Open
NNO	NPN Normally Open
NNC	NPN Normally Closed

Kit includes 1 sensor plus mounting screw.