

Rotary Servomotors

SGMSV

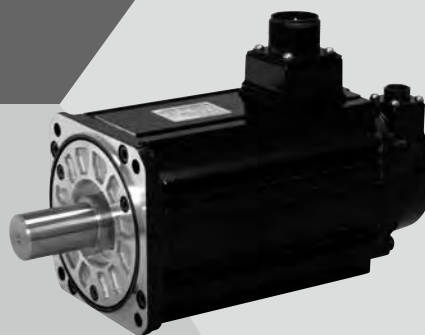

Model Designations

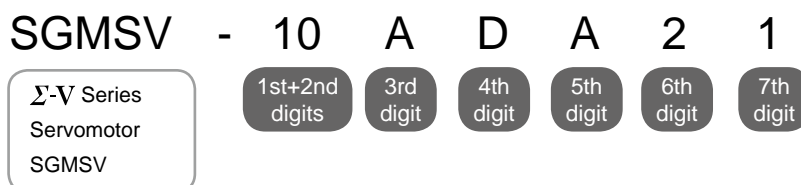

1st+2nd digits Rated Output

Code	Specifications
10	1.0 kW
15	1.5 kW
20	2.0 kW
25	2.5 kW
30	3.0 kW
40	4.0 kW
50	5.0 kW
70	7.0 kW*

*: Available only for 200-VAC models without brake.

3rd digit Power Supply Voltage

Code	Specifications
A	200 VAC
D	400 VAC

4th digit Serial Encoder

Code	Specifications
3	20-bit absolute
D	20-bit incremental

5th digit Design Revision Order

Code	Specifications
A	Standard

6th digit Shaft End

Code	Specifications
2	Straight without key
6	Straight with key and tap

7th digit Options

Code	Specifications
1	Without options
B	With holding brake (90 VDC)
C	With holding brake (24 VDC)
D	With oil seal and holding brake (90 VDC)
E	With oil seal and holding brake (24 VDC)
S	With oil seal

Limited Stock Items Non-Stock Items

Features

- Super high power
- Wide selection: 1.0 kW to 7.0 kW capacity, holding brake option
- Mounted serial encoder: 20 bits, high resolution
- Protective structure: IP67 (Not including the IP22 compliant enclosure for 7.0 kW motor)

Application Examples

- Chip mounters
- PCB drilling stations
- Machine tool feeders

Configurations of connectors for the main circuit

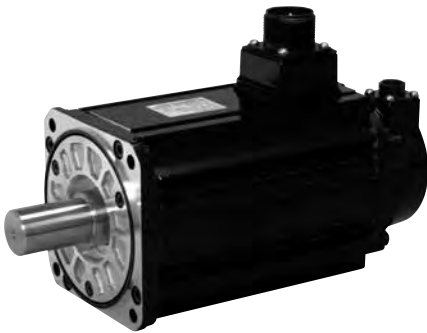

SGMSV-10 to -70

The connectors for these models are round. The connectors specified by Yaskawa are required. Note that the connectors vary depending on the operation environment of servomotors.

Two types of connectors are available.

- Standard connectors.
- Protective structure IP67 and European Safety Standards compliant connectors

Note: Connectors are not provided by Yaskawa.

Ratings and Specifications

Time Rating: Continuous
 Vibration Class: V15
 Insulation Resistance: 500 VDC, 10 MΩ min.
 Ambient Temperature: 0 to 40°C
 Excitation: Permanent magnet
 Mounting: Flange-mounted
 Thermal Class: F

Withstand Voltage: 1500 VAC for one minute (200-V class)
 1800 VAC for one minute (400-V class)

Enclosure: Totally enclosed, self-cooled, IP67
 (except for shaft opening)

Note: IP22 for SGMSV-70 servomotors.

Ambient Humidity: 20% to 80% (no condensation)

Drive Method: Direct drive

Rotation Direction: Counterclockwise (CCW) with forward run reference
 when viewed from the load side

200-V Class

Servomotor Model: SGMSV-□□□□		10A	15A	20A	25A	30A	40A	50A	70A
Rated Output*	kW	1.0	1.5	2.0	2.5	3.0	4.0	5.0	7.0
Rated Torque*	N·m	3.18	4.90	6.36	7.96	9.80	12.6	15.8	22.3
Instantaneous Peak Torque*	N·m	9.54	14.7	19.1	23.9	29.4	37.8	47.6	54
Rated Current*	A_{rms}	5.7	9.3	12.1	13.8	17.9	25.4	27.6	38.3
Instantaneous Max. Current*	A_{rms}	17	28	42	44.5	56	77	84	105
Rated Speed*	min^{-1}	3000							
Max. Speed*	min^{-1}	6000	5000						
Torque Constant	$N·m/A_{rms}$	0.636	0.590	0.561	0.610	0.582	0.519	0.604	0.604
Rotor Moment of Inertia	$\times 10^{-4} kg·m^2$	1.74 (1.99)	2.00 (2.25)	2.47 (2.72)	3.19 (3.44)	7.00 (9.2)	9.60 (11.8)	12.3 (14.5)	12.3
Rated Power Rate*	kW/s	58 (51)	120 (107)	164 (149)	199 (184)	137 (104)	165 (135)	203 (172)	404
Rated Angular Acceleration*	rad/s^2	18300 (16000)	24500 (21800)	25700 (23400)	25000 (23100)	14000 (10700)	13100 (10700)	12800 (10900)	18100
Applicable SERVOPACK	SGDV-□□□□	7R6A	120A	180A	200A	200A	330A	330A	550A

*: These items and torque-motor speed characteristics quoted in combination with a SERVOPACK are at an armature winding temperature of 20°C.

Notes: 1 The values in parentheses are for servomotors with holding brakes.

2 The above specifications show the values under the cooling condition when the following heat sinks are mounted on the servomotors.

SGMSV-10A/-15A/-20A/-25A : 300 mm×300 mm×12 mm (aluminum)

SGMSV-30A/-40A/-50A/-70A : 400 mm×400 mm×20 mm (aluminum)

400-V Class

Servomotor Model: SGMSV-□□□□		10D	15D	20D	25D	30D	40D	50D
Rated Output*	kW	1.0	1.5	2.0	2.5	3.0	4.0	5.0
Rated Torque*	N·m	3.18	4.9	6.36	7.96	9.8	12.6	15.8
Instantaneous Peak Torque*	N·m	9.54	14.7	19.1	23.9	29.4	37.8	47.6
Rated Current*	A_{rms}	2.8	4.7	6.1	7.4	8.9	12.5	13.8
Instantaneous Max. Current*	A_{rms}	8.5	14	20	25	28	38	42
Rated Speed*	min^{-1}	3000						
Max. Speed*	min^{-1}	6000	5000					
Torque Constant	$N·m/A_{rms}$	1.27	1.23	1.18	1.15	1.16	1.06	1.21
Rotor Moment of Inertia	$\times 10^{-4} kg·m^2$	1.74 (1.99)	2.00 (2.25)	2.47 (2.72)	3.19 (3.44)	7.00 (9.2)	9.60 (11.8)	12.3 (14.5)
Rated Power Rate*	kW/s	58 (51)	120 (107)	164 (149)	199 (184)	137 (104)	165 (135)	203 (172)
Rated Angular Acceleration*	rad/s^2	18300 (16000)	24500 (21800)	25700 (23400)	25000 (23100)	14000 (10700)	13100 (10700)	12800 (10900)
Applicable SERVOPACK	SGDV-□□□□	3R5D	5R4D	8R4D	120D	120D	170D	170D

*: These items and torque-motor speed characteristics quoted in combination with a SERVOPACK are at an armature winding temperature of 20°C.

Notes: 1 The values in parentheses are for servomotors with holding brakes.

2 The above specifications show the values under the cooling condition when the following heat sinks are mounted on the servomotors.

SGMSV-10D/-15D/-20D/-25D : 300 mm×300 mm×12 mm (aluminum)

SGMSV-30D/-40D/-50D : 400 mm×400 mm×20 mm (aluminum)

Ratings and Specifications

● Torque-Motor Speed Characteristics(200 V/400 V) **A**: Continuous Duty Zone **B**: Intermittent Duty Zone (Note1)

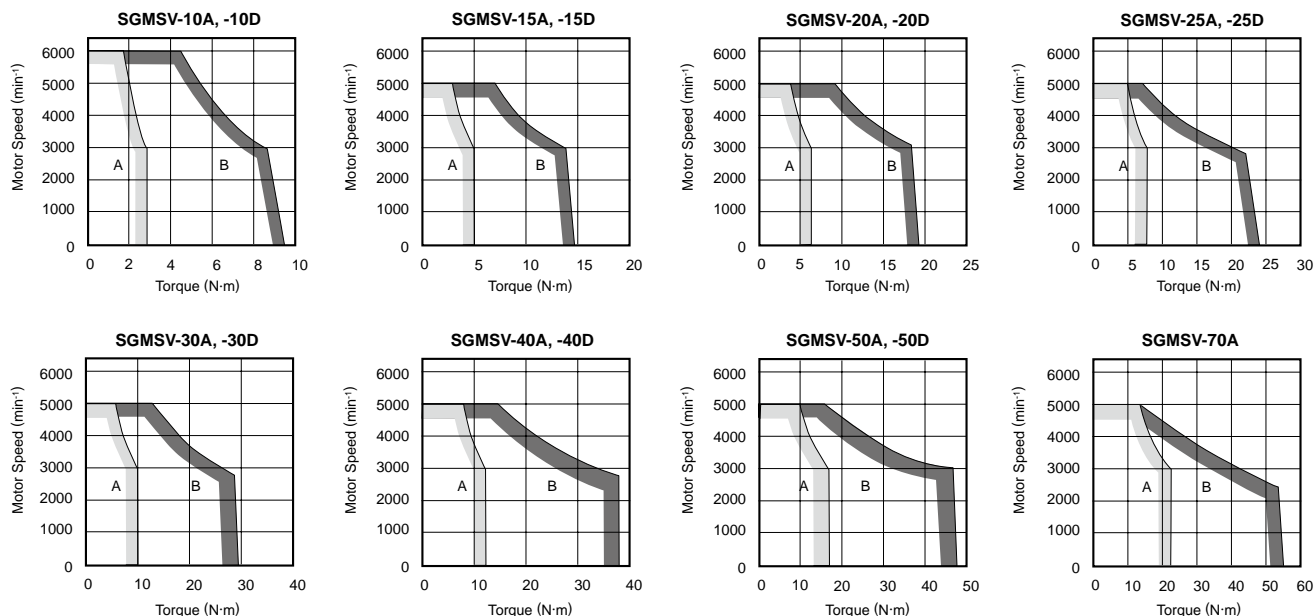

Note: 1 When the effective torque during intermittent duty is within the rated torque, the servomotor can be used within the intermittent duty zone.
 2 When the main circuit cable length exceeds 20 m, note that the intermittent duty zone of the Torque-Motor Speed Characteristics will shrink as the line-to-line voltage drops.

● Holding Brake Electrical Specifications

Servomotor Model	Servomotor Rated Output kW	Holding Brake Specifications				
		Holding Torque N·m	Rated Voltage 24 VDC		Rated Voltage 90 VDC	
			Capacity W	Rated Current A (at 20°C)	Capacity W	Rated Current A (at 20°C)
SGMSV-10	1.0	7.84	12	0.5	12	0.13
SGMSV-15	1.5	7.84	12	0.5	12	0.13
SGMSV-20	2.0	7.84	12	0.5	12	0.13
SGMSV-25	2.5	10	12	0.5	12	0.13
SGMSV-30	3.0	20	10	0.41	10	0.11
SGMSV-40	4.0	20	10	0.41	10	0.11
SGMSV-50	5.0	20	10	0.41	10	0.11

Notes: 1 The holding brake is only used to hold the load and cannot be used to stop the servomotor.
 2 The holding brake open time and holding brake operation time vary depending on which discharge circuit is used. Make sure holding brake open time and holding brake operation time are correct for your servomotor.
 3 A 24 VDC power supply is to be provided by customers.

Ratings and Specifications

● Allowable Load Moment of Inertia at the Motor Shaft

The rotor moment of inertia ratio is the value for a servomotor without a gear and a holding brake.

Servomotor Model	Servomotor Rated Output	Allowable Load Moment of Inertia (Rotor Moment of Inertia Ratio)
SGMSV-10 to -70	1.0 to 7.0 kW	5 times

● Load Moment of Inertia

The larger the load moment of inertia, the worse the movement response.

The allowable load moment of inertia (J_L) depends on motor capacity, as shown above. This value is provided strictly as a guideline and results may vary depending on servomotor drive conditions.

Use the AC servo drive capacity selection program SigmaJunmaSize+ to check the operation conditions.

The program can be downloaded for free from our web site (<http://www.e-mechatronics.com/>).

An overvoltage alarm (A.400) is likely to occur during deceleration if the load moment of inertia exceeds the allowable load moment of inertia. SERVOPACKs with a built-in regenerative resistor may generate a regenerative overload alarm (A.320). Take one of the following steps if this occurs.

- Reduce the torque limit.
- Reduce the deceleration rate.
- Reduce the maximum speed.
- Install an external regenerative resistor if the alarm cannot be cleared using the steps above. Refer to Regenerative Resistors on page 386.

● Allowable Radial and Thrust Loads

Design the mechanical system so thrust and radial loads applied to the servomotor shaft end during operation fall within the ranges shown in the table.

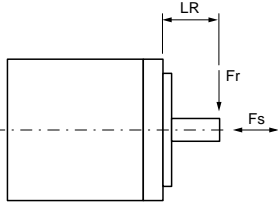
Servomotor Model		Allowable Radial Load (F_r) N	Allowable Thrust Load (F_s) N	LR mm	Reference Diagram
SGMSV-	10□□A21	686	196	45	
	15□□A21				
	20□□A21				
	25□□A21	980	392	63	
	30□□A21				
	40□□A21	1176	392	63	
	50□□A21				
70□□A21					

External Dimensions Units: mm

● Without Holding Brakes

(1) 1.0 to 5.0 kW

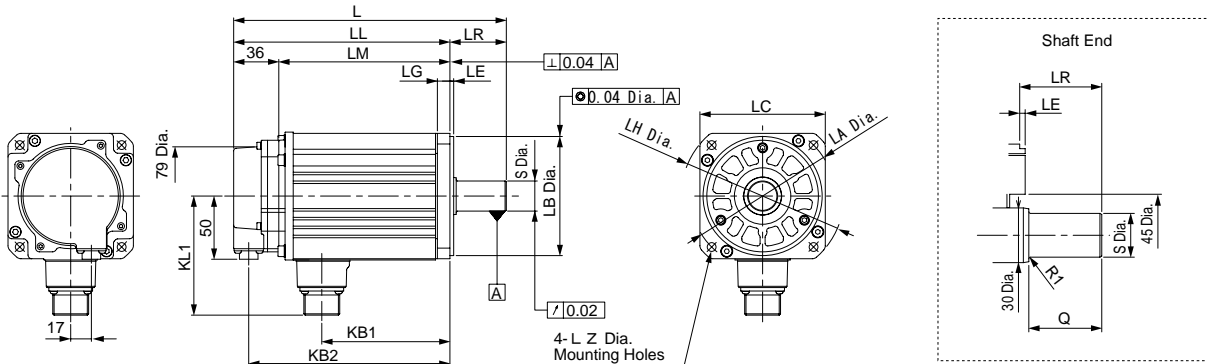

Note: For the specifications of the other shaft ends, refer to page 79.

Model SGMSV-	L	LL	LM	LR	KB1	KB2	KL1	Flange Face Dimensions								Shaft End Dimensions		Approx. Mass kg
								LA	LB	LC	LE	LF	LG	LH	LZ	S	Q	
10□□A21	192	147	111	45	76	135	96	115	95 ⁰ _{-0.035}	100	3	3	10	130	7	24 ⁰ _{-0.013}	40	4.1
15□□A21	202	157	121	45	86	145	96	115	95 ⁰ _{-0.035}	100	3	3	10	130	7	24 ⁰ _{-0.013}	40	4.6
20□□A21	218	173	137	45	102	161	96	115	95 ⁰ _{-0.035}	100	3	3	10	130	7	24 ⁰ _{-0.013}	40	5.4
25□□A21	241	196	160	45	125	184	96	115	95 ⁰ _{-0.035}	100	3	3	10	130	7	24 ⁰ _{-0.013}	40	6.8
30□□A21	259	196	160	63	124	184	114	145	110 ⁰ _{-0.035}	130	6	6	12	165	9	28 ⁰ _{-0.013}	55	10.5
40□□A21	296	233	197	63	161	221	114	145	110 ⁰ _{-0.035}	130	6	6	12	165	9	28 ⁰ _{-0.013}	55	13.5
50□□A21	336	273	237	63	201	261	114	145	110 ⁰ _{-0.035}	130	6	6	12	165	9	28 ⁰ _{-0.013}	55	16.5

Note: Models with oil seals are of the same configuration.

· Cable Specifications for Encoder-end Connector (20-bit Encoder)

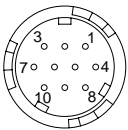

Receptacle: CM10-R10P-D
 Applicable plug (To be provided by the customer)
 Plug: CM10-AP10S-□-D (Angle)
 CM10-SP10S-□-D (Straight)
 (Boxes □ indicate a value that varies, depending on cable size.)
 Manufacturer: DDK Ltd.

With an Absolute Encoder

1	PS	6	BAT (+)
2	/PS	7	-
3	-	8	-
4	PG 5V	9	PG 0V
5	BAT (-)	10	FG (Frame ground)

With an Incremental Encoder

1	PS	6	-
2	/PS	7	-
3	-	8	-
4	PG 5V	9	PG 0V
5	-	10	FG (Frame ground)

· Cable Specifications for Servomotor-end Connector

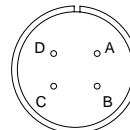

A	Phase U
B	Phase V
C	Phase W
D	FG (Frame ground)

· SGMSV-10 to -25
 Manufacturer: DDK Ltd.
 · SGMSV-30 to -50
 Manufacturer: Japan Aviation Electronics Industry, Ltd.

External Dimensions Units: mm

(2) 7.0 kW (only for 200 V servomotors)

- Notes: 1 Leave a minimum space of 70 mm around the servomotor to allow for a sufficient amount of cooling air.
 2 Cooling Fan : single-phase 220 V, 50/60Hz, 17/15 W, 0.11/0.09 A

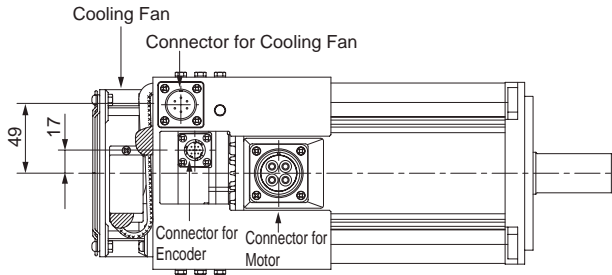
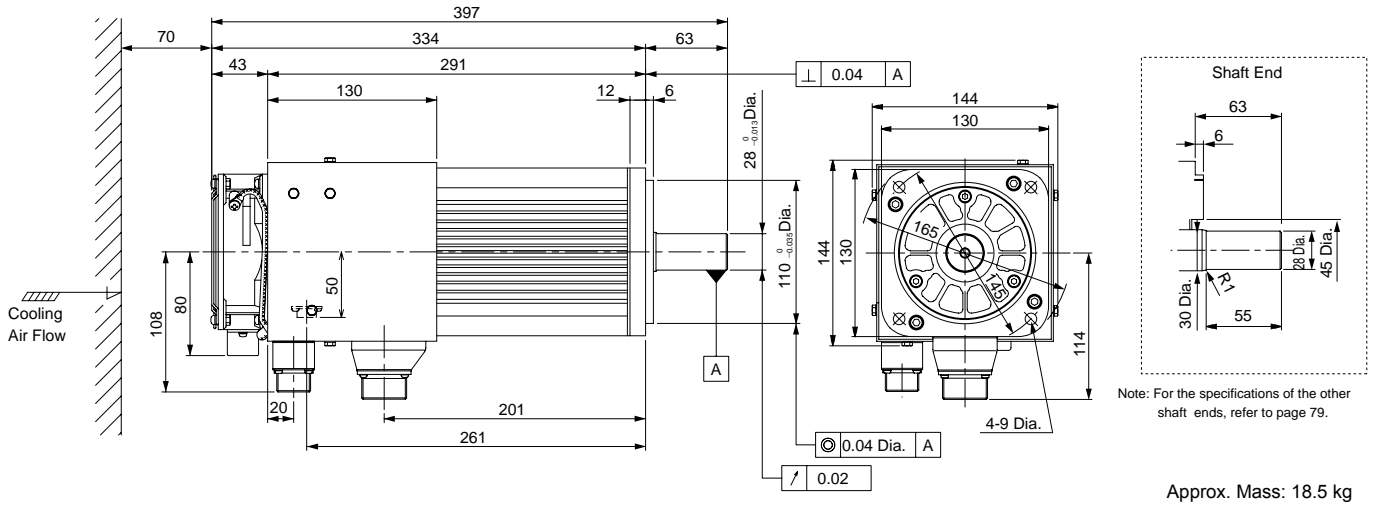

· Cable Specifications for Servomotor-end Connector

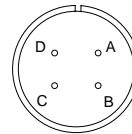

A	Phase U
B	Phase V
C	Phase W
D	FG (Frame ground)

Manufacturer: Japan Aviation Electronics Industry, Ltd.

· Cable Specifications for Fan-end Connector

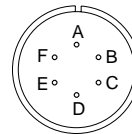

Receptacle: MS3102A14S-6P
 Applicable plug
 Plug: MS3108B14S-6S
 Cable clamp: MS3057-6A

Note: Servomotor-end connectors (receptacles) are RoHS-compliant. Contact the respective connector manufacturers for RoHS-compliant cable-end connectors.

- Specifications of Cooling Fan
 - Single-phase 220 V
 - 50/60 Hz
 - 17/15 W
 - 0.11/0.09 A
- Specifications of rotation error detector
 - Contact Capacity:
 - Max. allowable voltage: 350 V (AC, DC)
 - Max. allowable current: 120 mA (AC, DC)
 - Max. controllable power: 360 mW
 - Alarm Contact:
 - ON at normal fan rotation.
 - OFF at 1680±100 min⁻¹ or less.
 - (OFF during 3 seconds at start-up)

· Cable Specifications for Encoder-end Connector (20-bit Encoder)

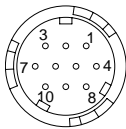

Receptacle: CM10-R10P-D
 Applicable plug (To be provided by the customer)
 Plug: CM10-SP10S-□-D (Straight)
 (Boxes (□) indicate a value that varies, depending on cable size.)
 Use straight plugs to avoid interference with the fan cover.
 Manufacturer: DDK Ltd.

A	Fan motor
B	Fan motor
C	—
D	Alarm terminal
E	Alarm terminal
F	FG (Frame ground)

With an Absolute Encoder

1	PS	6	BAT (+)
2	/PS	7	—
3	—	8	—
4	PG 5V	9	PG 0V
5	BAT (-)	10	FG (Frame ground)

With an Incremental Encoder

1	PS	6	—
2	/PS	7	—
3	—	8	—
4	PG 5V	9	PG 0V
5	—	10	FG (Frame ground)

External Dimensions Units: mm

● With Holding Brakes

(1) 1.0 to 5.0 kW

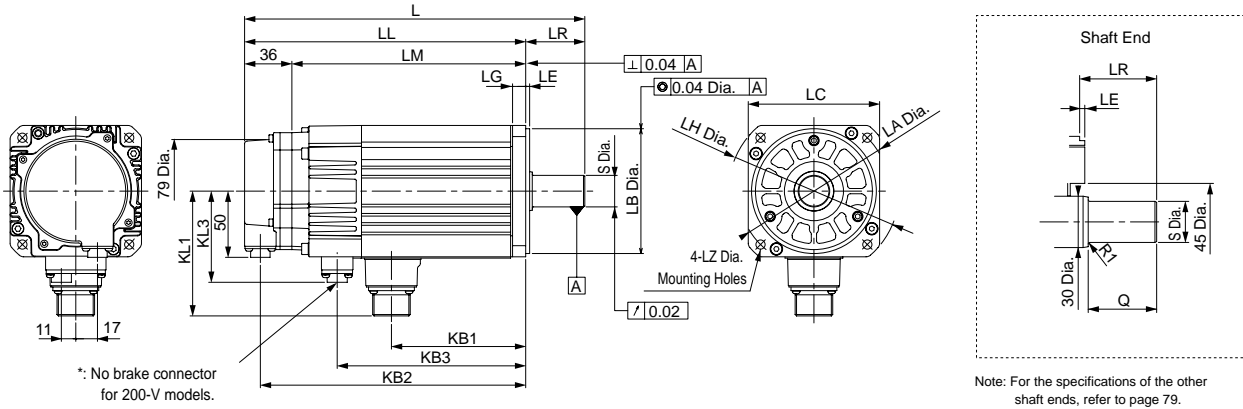

Model SGMSV-	L	LL	LM	LR	KB1		KB2	KB3*	KL1	KL3*	Flange Face Dimensions							Shaft End Dimensions		Approx. Mass □		
					200V	400V					LA	LB	LC	LE	LF	LG	LH	LZ	S		Q	
10□□A2□	233	188	152	45	67	76	176	118	102	96	69	115	95 ⁰ _{0.035}	100	3	3	10	130	7	24 ⁰ _{0.013}	40	5.5
15□□A2□	243	198	162	45	77	86	186	128	102	96	69	115	95 ⁰ _{0.035}	100	3	3	10	130	7	24 ⁰ _{0.013}	40	6
20□□A2□	259	214	178	45	93	102	202	144	102	96	69	115	95 ⁰ _{0.035}	100	3	3	10	130	7	24 ⁰ _{0.013}	40	6.8
25□□A2□	292	247	211	45	116	125	225	177	102	96	69	115	95 ⁰ _{0.035}	100	3	3	10	130	7	24 ⁰ _{0.013}	40	8.7
30□□A2□	295	232	196	63	114	124	220	176	119	114	81	145	110 ⁰ _{0.035}	130	6	6	12	165	9	28 ⁰ _{0.013}	55	13
40□□A2□	332	269	233	63	151	161	257	213	119	114	81	145	110 ⁰ _{0.035}	130	6	6	12	165	9	28 ⁰ _{0.013}	55	16
50□□A2□	372	309	273	63	191	201	297	253	119	114	81	145	110 ⁰ _{0.035}	130	6	6	12	165	9	28 ⁰ _{0.013}	55	19

*: No brake connector for 200-V models (there are brake terminals on the servomotor-end connectors).
Note: Models with oil seals are of the same configuration.

· Cable Specifications for Encoder-end Connector (20-bit Encoder)

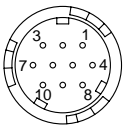

Receptacle: CM10-R10P-D
Applicable plug (To be provided by the customer)
Plug: CM10-AP10S-□-D (Angle)
CM10-SP10S-□-D (Straight)
(Boxes (□) indicate a value that varies, depending on cable size.)
Manufacturer: DDK Ltd.

With an Absolute Encoder

1	PS	6	BAT (+)
2	/PS	7	-
3	-	8	-
4	PG 5V	9	PG 0V
5	BAT (-)	10	FG (Frame ground)

With an Incremental Encoder

1	PS	6	-
2	/PS	7	-
3	-	8	-
4	PG 5V	9	PG 0V
5	-	10	FG (Frame ground)

200-V Class

· Cable Specifications for Servomotor-end Connector

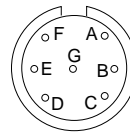

A	Phase U
B	Phase V
C	Phase W
D	FG (Frame ground)
E	Brake terminal
F	Brake terminal
G	-

Manufacturer: Japan Aviation Electronics Industry, Ltd.

Note: No polarity for connection to the brake terminals

400-V Class

· Cable Specifications for Servomotor-end Connector

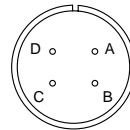

A	Phase U
B	Phase V
C	Phase W
D	FG (Frame ground)

· SGMSV-10 to -25
Manufacturer: DDK Ltd.
· SGMSV-30 to -50
Manufacturer: Japan Aviation Electronics Industry, Ltd.

· Cable Specifications for Brake-end Connector

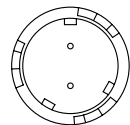

Receptacle: CM10-R2P-D
Applicable plug (To be provided by the customer)
Plug: CM10-AP2S-□-D (Angle)
CM10-SP2S-□-D (Straight)
(Boxes (□) indicate a value that varies, depending on cable size.)
Manufacturer: DDK Ltd.

Brake terminal
Brake terminal

Note: No polarity for connection to the brake terminals

External Dimensions Units: mm

● Shaft End

SGMSV - □□□□□□□

Code	Specifications	Remarks
2	Straight without key	Optional/Non-stock
6	Straight with key and tap for one location (Key slot is JIS B1301-1996 fastening type)	Standard/Stock

Code	Specifications	Shaft End	Model SGMSV-								
			10	15	20	25	30	40	50	70	
2	Straight without Key		LR	45				63			
			Q	40				55			
			S	24 ⁰ _{-0.013}				28 ⁰ _{-0.013}			
6	Straight with Key and Tap		LR	45				63			
			Q	40				55			
			QK	32				50			
			S	24 ⁰ _{-0.013}				28 ⁰ _{-0.013}			
			W	8							
			T	7							
			U	4							
P	M8 Screw Depth16										

Selecting Cables

● Cables Connections

- Standard Wiring (Max. encoder cable length: 20 m)

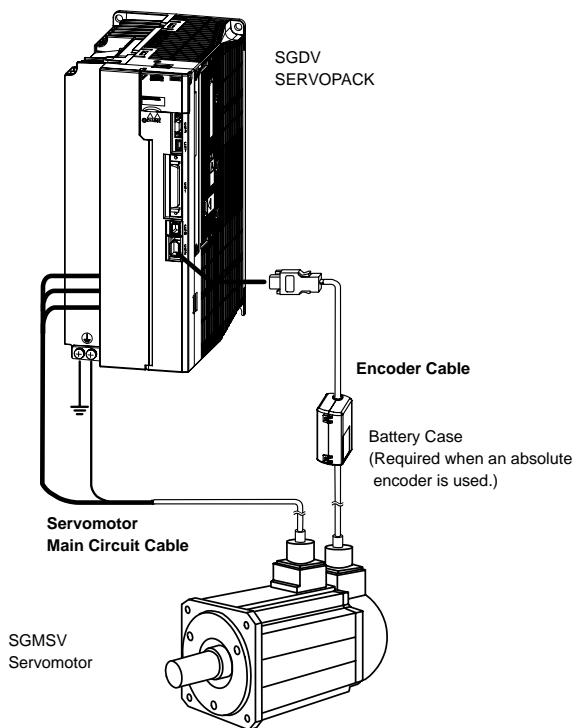

- Encoder Cable Extension from 30 to 50 m

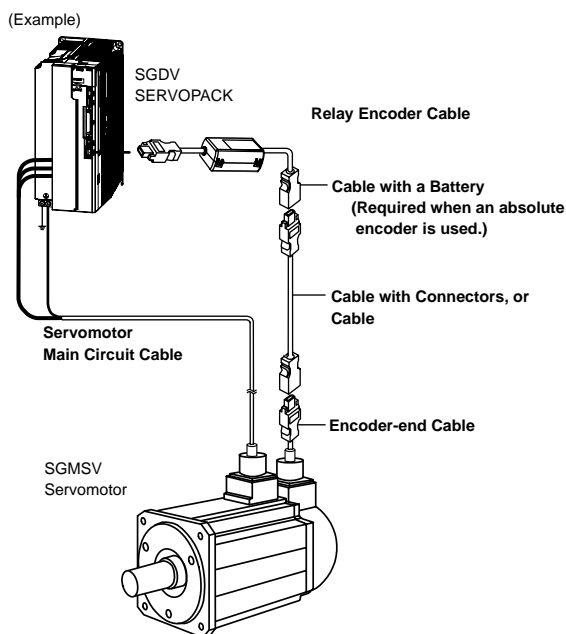

CAUTION

- Separate the servomotor main circuit cable wiring from the I/O signal cable and encoder cable at least 30 cm, and do not bundle or run them in the same duct.
- When the main circuit cable length exceeds 20 m, note that the intermittent duty zone of the Torque-Motor Speed Characteristics will shrink as the line-to-line voltage drops.

Selecting Cables

● Servomotor Main Circuit Cables

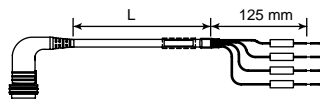
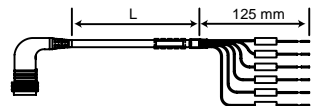
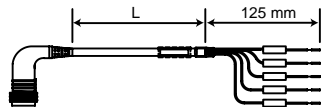
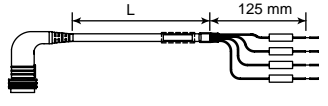
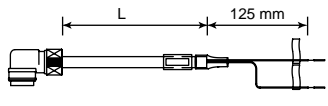
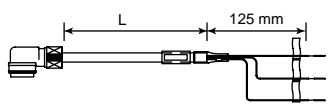
Voltage	Name	Servomotor Rated Output	Length	Order No.		Specifications	Details
				Value Type	Premium Type ²		
200V	Servomotor Power Cable (for Servomotor without Holding Brake)	1.0kW to 2.5kW	3 m	B1EV-03(A)-E	B1EP-03(A)-E		(1)
			5 m	B1EV-05(A)-E	B1EP-05(A)-E		
			10 m	B1EV-10(A)-E	B1EP-10(A)-E		
			15 m	B1EV-15(A)-E	B1EP-15(A)-E		
		20 m	B1EV-20(A)-E	B1EP-20(A)-E			
		3.0kW	3 m	B3EV-03(A)-E	B3EP-03(A)-E		
			5 m	B3EV-05(A)-E	B3EP-05(A)-E		
			10 m	B3EV-10(A)-E	B3EP-10(A)-E		
			15 m	B3EV-15(A)-E	B3EP-15(A)-E		
		4.0 to 7.0kW ⁴	3 m	B4EV-03(A)-E	B4EP-03(A)-E		
			5 m	B4EV-05(A)-E	B4EP-05(A)-E		
			10 m	B4EV-10(A)-E	B4EP-10(A)-E		
	15 m		B4EV-15(A)-E	B4EP-15(A)-E			
	Servomotor Power Cable (for Servomotor with Holding Brake) ³	1.0kW to 2.5kW	3 m	BABEV-03(A)-E	BABEP-03(A)-E		(5)
			5 m	BABEV-05(A)-E	BABEP-05(A)-E		
			10 m	BABEV-10(A)-E	BABEP-10(A)-E		
			15 m	BABEV-15(A)-E	BABEP-15(A)-E		
		20 m	BABEV-20(A)-E	BABEP-20(A)-E			
		3.0kW	3 m	BCBEV-03(A)-E	BCBEP-03(A)-E		
			5 m	BCBEV-05(A)-E	BCBEP-05(A)-E		
10 m			BCBEV-10(A)-E	BCBEP-10(A)-E			
15 m			BCBEV-15(A)-E	BCBEP-15(A)-E			
4.0 to 5.0kW ⁴		3 m	BDBEV-03(A)-E	BDBEP-03(A)-E			
		5 m	BDBEV-05(A)-E	BDBEP-05(A)-E			
		10 m	BDBEV-10(A)-E	BDBEP-10(A)-E			
	15 m	BDBEV-15(A)-E	BDBEP-15(A)-E				
Fan Cable	7.0kW	3 m	BFEV-03(A)-E	-		(4)	
		5 m	BFEV-05(A)-E	-			
		10 m	BFEV-10(A)-E	-			
		15 m	BFEV-15(A)-E	-			
		20 m	BFEV-20(A)-E	-			
400V	Servomotor Power Cable (for Servomotor with or without Holding Brake) ¹	1.0kW to 2.5kW	3 m	B1EV-03(A)-E	B1EP-03(A)-E		(1)
			5 m	B1EV-05(A)-E	B1EP-05(A)-E		
			10 m	B1EV-10(A)-E	B1EP-10(A)-E		
			15 m	B1EV-15(A)-E	B1EP-15(A)-E		
		20 m	B1EV-20(A)-E	B1EP-20(A)-E			
		3.0 to 5.0kW	3 m	B3EV-03(A)-E	B3EP-03(A)-E		
			5 m	B3EV-05(A)-E	B3EP-05(A)-E		
			10 m	B3EV-10(A)-E	B3EP-10(A)-E		
	15 m		B3EV-15(A)-E	B3EP-15(A)-E			
	Holding Brake Cable	1kW to 5kW	3 m	BBEV-03(A)-E	-		(2)
			5 m	BBEV-05(A)-E	-		
			10 m	BBEV-10(A)-E	-		
			15 m	BBEV-15(A)-E	-		(3)
			20 m	BBEV-20(A)-E	-		
			3 m	-	BBEP-03(A)-E		
			5 m	-	BBEP-05(A)-E		
			10 m	-	BBEP-10(A)-E		
15 m			-	BBEP-15(A)-E			
20 m	-	BBEP-20(A)-E					

*1 400V Servomotors with holding brakes require a holding brake cable in addition to a power cable.

*2 Premium cables have a braided cable shield and are intended for use in applications that require CE. Premium cables have a continuous flex rating and are intended for use in movable sections such as robot arms.

*3 200V servomotors with holding brakes use a combined power and brake cable

*4 The 7.0kW, 200V servomotor requires a separate fan cable. 7.0kW units are not available with holding brake.

Selecting Cables

(1) Wiring Specifications for 200V and 400V Servomotors without Holding Brakes*

● Value Type

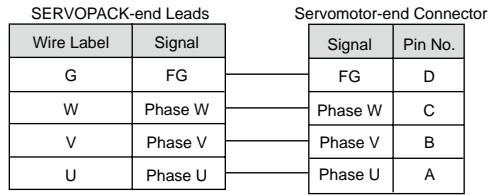

*400V servomotors with holding brakes require a separate holding brake cable. See (2) and (3).

● Premium Type

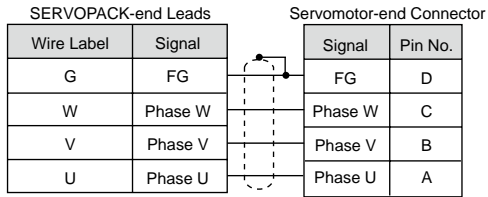

*400V servomotors with holding brakes require a separate holding brake cable. See (2) and (3).

(2) Wiring Specifications for the Value Type Brake Cable for 400V Servomotors

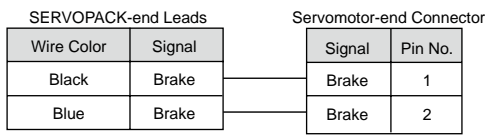

Note: No polarity for connection to a holding brake.

(3) Wiring Specifications for the Premium Type Brake Cable for 400V Servomotors

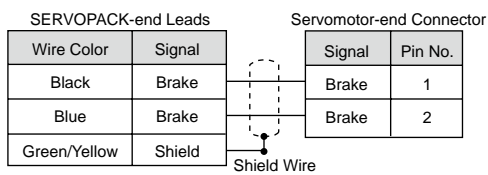

Note: No polarity for connection to a holding brake.

(4) Wiring Specifications for the Fan on 200V 7.0kW Servomotors

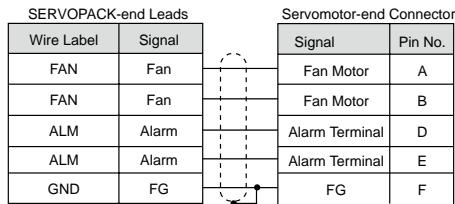

Notes:

No polarity for connection to a fan.

No polarity for connection to an alarm circuit.

(5) Wiring Specifications for 200V Servomotors with Holding Brakes

● Value Type

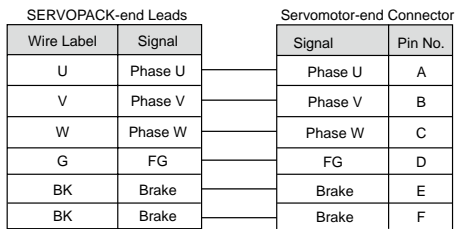

Note: No polarity for connection to a holding brake.

● Premium Type

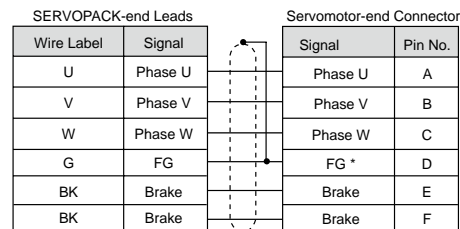

Note: No polarity for connection to a holding brake.

* For 200V Premium Cable, shield is connected to FG wire on the servomotor-end of the cable.

● Customer Cable Assembly

Customers may assemble the servomotor's main circuit cables and attach connectors to connect the SERVOPACKS and the SGMSV servomotors.

The connectors for these models are round. The connectors specified by Yaskawa are required. Note that the connectors vary depending on the operation environment of servomotors.

Two types of connectors are available.

- Standard connectors
- Protective structure IP67 and European Safety Standards compliant connectors

Yaskawa does not specify which cables to use. Use appropriate cables for the connectors.

Selecting Cables

● Standard Connectors

● Connector Configuration

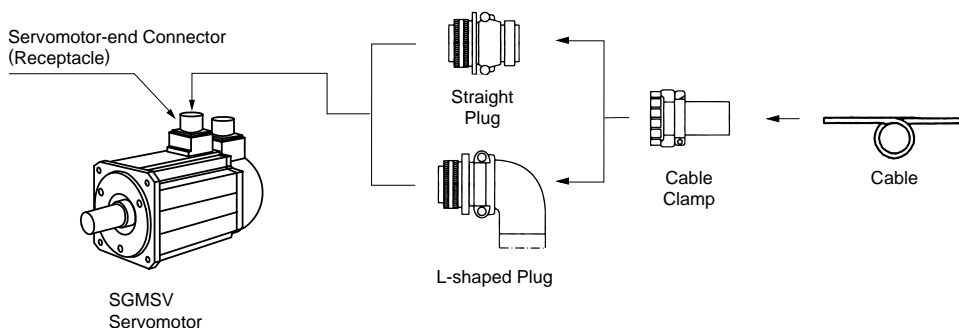

(1) Without Holding Brakes

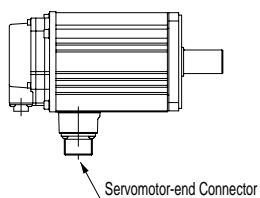

Servomotor-end Connector
For 1.0 to 7.0 kW

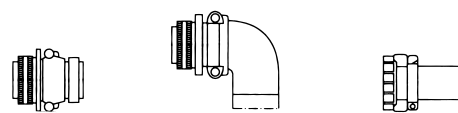

Capacity kW	Servomotor-end Connector (Receptacle)	Cable-end Connector (Not provided by Yaskawa)		
		Straight Plug	L-shaped Plug	Cable Clamp
1.0 to 2.5	MS3102A18-10P	MS3106B18-10S	MS3108B18-10S	MS3057-10A
3.0 to 7.0	MS3102A22-22P	MS3106B22-22S	MS3108B22-22S	MS3057-12A

Note: Servomotor-end connectors (receptacles) are RoHS-compliant. Contact the respective connector manufacturers for RoHS-compliant cable-end connectors.

(2) With Holding Brakes (200 V)

No brake connector for 200-V models
(there are brake terminals on the servomotor-end connectors).

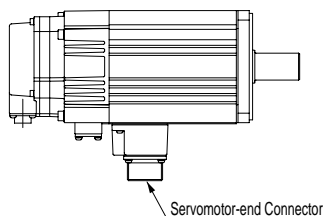

Servomotor-end Connector
For 1.0 to 5.0 kW

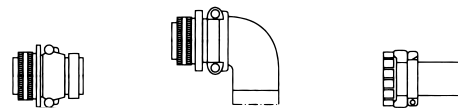

Capacity kW	Servomotor-end Connector (Receptacle)	Cable-end Connector (Not provided by Yaskawa)		
		Straight Plug	L-shaped Plug	Cable Clamp
1.0 to 2.5	MS3102A20-15P	MS3106B20-15S	MS3108B20-15S	MS3057-12A
3.0 to 5.0	MS3102A24-10P	MS3106B24-10S	MS3108B24-10S	MS3057-16A

Note: Servomotor-end connectors (receptacles) are RoHS-compliant. Contact the respective connector manufacturers for RoHS-compliant cable-end connectors.

Selecting Cables

(3) With Holding Brakes (400 V)

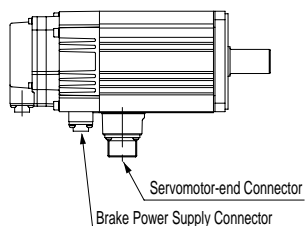

Servomotor-end Connector
For 1.0 to 5.0 kW

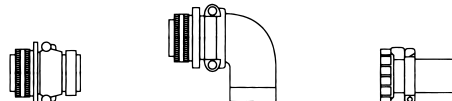

Capacity kW	Servomotor-end Connector (Receptacle)	Cable-end Connector (Not provided by Yaskawa)		
		Straight Plug	L-shaped Plug	Cable Clamp
1.0 to 2.5	MS3102A18-10P	MS3106B18-10S	MS3108B18-10S	MS3057-10A
3.0 to 5.0	MS3102A22-22P	MS3106B22-22S	MS3108B22-22S	MS3057-12A

Note: Servomotor-end connectors (receptacles) are RoHS-compliant. Contact the respective connector manufacturers for RoHS-compliant cable-end connectors.

Brake Power Supply Connector
For 1.0 to 5.0 kW

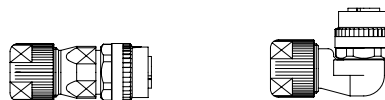

Capacity kW	Servomotor-end Connector (Receptacle)	Cable-end Connector (Not provided by Yaskawa)		
		Straight Plug	L-shaped Plug	Manufacturer
1.0 to 5.0	CM10-R2P-D	CM10-SP2S-S-D Applicable Cable: 4.0 dia. to 6.0 dia.	CM10-AP2S-S-D Applicable Cable: 4.0 dia. to 6.0 dia.	DDK Ltd.
		CM10-SP2S-M-D Applicable Cable: 6.0 dia. to 9.0 dia.	CM10-AP2S-M-D Applicable Cable: 6.0 dia. to 9.0 dia.	
		CM10-SP2S-L-D Applicable Cable: 9.0 dia. to 11.6 dia.	CM10-AP2S-L-D Applicable Cable: 9.0 dia. to 11.6 dia.	

To order a brake power supply connector kit (1.0 to 5.0 kW) with the order no. below, contact your Yaskawa representative.

J Z S P - C V B 9 - S M S 2 - E

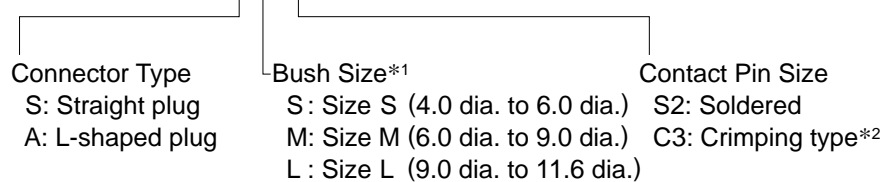

*1: A size-M connector kit is available as standard equipment.
*2: A crimp tool (model: 357J-50448T) by DDK Ltd. is required.

Selecting Cables Units: mm

• Cable-end Connectors

(1) MS3106B□□-□□S : Straight Plug

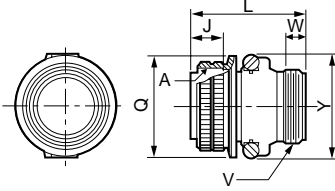

Shell Size	Joint Screw A	Length of Joint Portion J±0.12	Overall Length L max.	Outer Diameter of Joint Nut Q ⁺⁰ _{-0.38}	Cable Clamp Set Screw V	Effective Screw Length W min.	Maximum Width Y max.
18	1-1/8-18UNEF	18.26	52.37	34.13	1-20UNEF	9.53	42
20	1-1/4-18UNEF	18.26	55.57	37.28	1-3/16-18UNEF	9.53	47
22	1-3/8-18UNEF	18.26	55.57	40.48	1-3/16-18UNEF	9.53	50
24	1-1/2-18UNEF	18.26	58.72	43.63	1-7/16-18UNEF	9.53	53

(2) MS3108B□□-□□S : L-shaped Plug

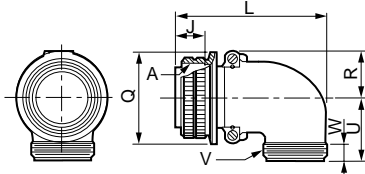

Shell Size	Joint Screw A	Length of Joint Portion J±0.12	Overall Length L max.	Outer Diameter of Joint Nut Q ⁺⁰ _{-0.38}	R ±0.5	U ±0.5	Cable Clamp Set Screw V	Effective Screw Length W min.
18	1-1/8-18UNEF	18.26	68.27	34.13	20.5	30.2	1-20UNEF	9.53
20	1-1/4-18UNEF	18.26	76.98	37.28	22.5	33.3	1-3/16-18UNEF	9.53
22	1-3/8-18UNEF	18.26	76.98	40.48	24.1	33.3	1-3/16-18UNEF	9.53
24	1-1/2-18UNEF	18.26	86.51	43.63	25.6	36.5	1-7/16-18UNEF	9.53

(3) MS3057-□□A : Cable Clamp with Rubber Bushing

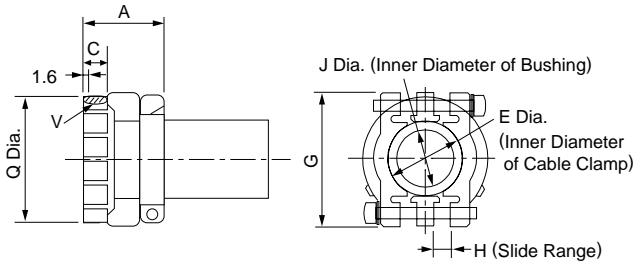

Cable Clamp Type	Applicable Connector Shell Size	Overall Length A±0.7	Effective Screw Length C	E Diameter	G±0.7	H	J Diameter	Set Screw V	Outer Diameter Q±0.7 Dia.	Attached Bushing
MS3057-10A	18	23.8	10.3	15.9	31.7	3.2	14.3	1-20UNEF	30.1	AN3420-10
MS3057-12A	20□22	23.8	10.3	19	37.3	4	15.9	1-3/16-18UNEF	35.0	AN3420-12
MS3057-16A	24	26.2	10.3	23.8	42.9	4.8	19.1	1-7/16-18UNEF	42.1	AN3420-16

• Dimensional Drawings of Brake Power Supply

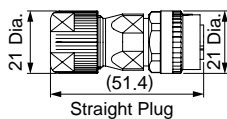
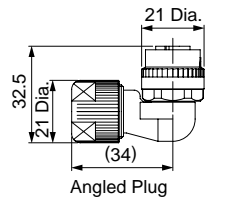

Items	Specifications
Connector Order No.	CM10-□P2S-□-D (Cables are not included.)
Protective Structure	IP67
Manufacturer	DDK Ltd.
Instructions	Angled plug (CM10-AP2S-□-D): TC-573, Straight plug (CM10-SP2S-□-D): TC-583
Electrical Contact Order No.	<p>Electrical contact (100 pcs in one bag)</p> <ul style="list-style-type: none"> Crimping type: CM10-#22SC(C3)-100, Wire size: AWG16 to 20, Outer diameter of sheath: 1.87 to 2.45 dia., Hand tool: 357J-50448T Soldered type: CM10-#22SC (S2)-100, Wire size: AWG16 max. <p>Real contact (4000 pcs on one reel)</p> <ul style="list-style-type: none"> Crimping type: CM10-#22SC(C3)-4000, Wire size: AWG 16 to 20, Outer diameter of sheath: 1.87 to 2.45 dia., <p>Semi-automatic tool: AP-A50541T (product name for one set), AP-A50541T-1 (product name for applicator)</p> <p>Note: The product name of the semi-automatic tool refers to the product name of the press and applicator (crimper) as a set.</p>

Selecting Cables

● Protective Structure IP67 and European Safety Standards Compliant Connector

● Connector Configuration

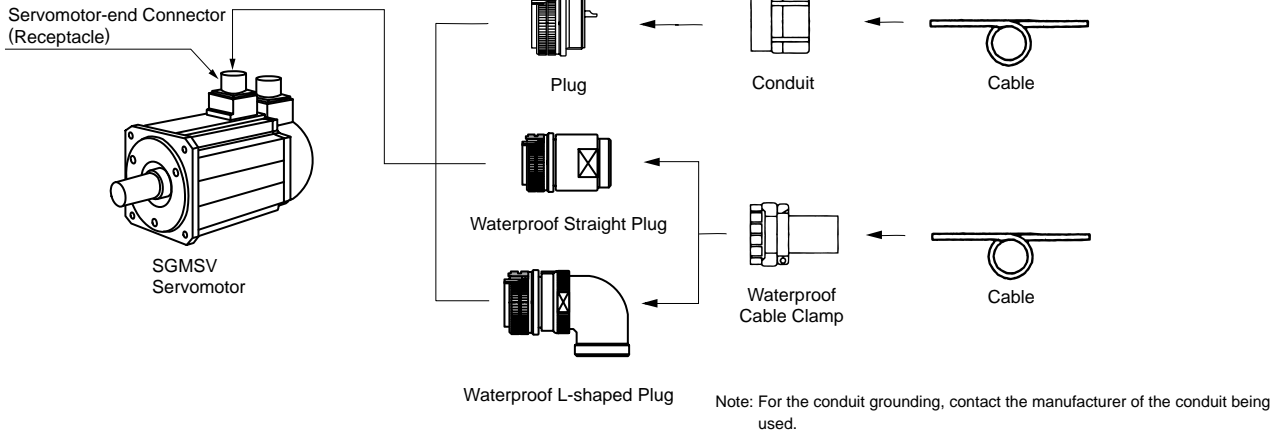

(1) Without Holding Brakes

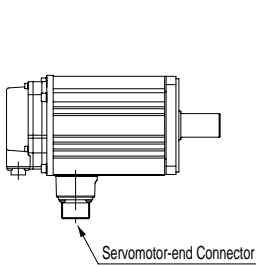

Servomotor-end Connector
For 1.0 to 7.0 kW

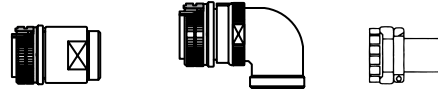

Capacity kW	Servomotor-end Connector (Receptacle)	Cable-end Connector (Not Provided by Yaskawa)					Applicable Cable Diameter (For Reference)	Manufacturer
		Plug	Straight Plug	L-shaped Plug	Cable Clamp			
1.0 to 2.5	CE05-2A18- 10PD-D	CE05- 6A18- 10SD-D	CE05-6A18- 10SD-D-BSS	CE05-8A18- 10SD-D-BAS	CE3057-10A-1-D	10.5 dia. to 14.1 dia.	DDK Ltd.	
					CE3057-10A-2-D	8.5 dia. to 11.0 dia.		
					CE3057-10A-3-D	6.5 dia. to 8.7 dia.		
3.0 to 7.0	JL04HV-2E22- 22PE-B-R	JL04V- 6A22- 22SE-R	JL04V-6A22-22SE-EB-R or JA06A-22-22S-J1-EB-R*	JL04V-8A22-22SE-EB-R or JA08A-22-22S-J1-EB-R*	JL04-2022CK (09) -R	6.5 Dia. to 9.5 Dia.	Japan Aviation Electronics Industry, Ltd.	
					JL04-2022CK (12) -R	9.5 Dia. to 13.0 Dia.		
					JL04-2022CK (14) -R	12.9 Dia. to 15.9 Dia.		

*: Not compliant with European Safety Standards, but compliant with protective structure IP67.

(2) With Holding Brakes (200 V)

No brake connector for 200-V models
(there are brake terminals on the servomotor-end connectors).

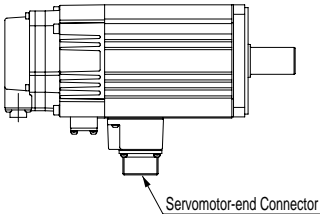

Servomotor-end Connector
For 1.0 to 5.0 kW

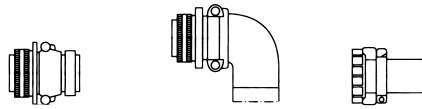

Capacity kW	Servomotor-end Connector (Receptacle)	Cable-end Connector (Not Provided by Yaskawa)					Applicable Cable Diameter (For Reference)	Manufacturer
		Plug	Straight Plug	L-shaped Plug	Cable Clamp			
1.0 to 2.5	JL04V-2E20- 15PE-B-R	JL04V- 6A20- 15SE-R	JL04V-6A20-15SE-EB-R	JL04V-8A20-15SE-EB-R	JL04-2022CK (09) -R	6.5 Dia. to 9.5 Dia.	Japan Aviation Electronics Industry, Ltd.	
					JL04-2022CK (12) -R	9.5 Dia. to 13.0 Dia.		
					JL04-2022CK (14) -R	12.9 Dia. to 15.9 Dia.		
3.0 to 5.0	JL04V-2E24- 10PE-B-R	JL04- 6A24- 10SE-R	JL04V-6A24-10SE-EB-R or JA06A-24-10S-J1-EB-R*	JL04V-8A24-10SE-EB-R or JA08A-24-10S-J1-EB-R*	JL04-2428CK (11) -R	9.0 Dia. to 12.0 Dia.	Japan Aviation Electronics Industry, Ltd.	
					JL04-2428CK (14) -R	12.0 Dia. to 15.0 Dia.		
					JL04-2428CK (17) -R	15.0 Dia. to 18.0 Dia.		
					JL04-2428CK (20) -R	18.0 Dia. to 20.0 Dia.		

*: Not compliant with European Safety Standards, but compliant with protective structure IP67.

Selecting Cables

(3) With Holding Brakes (400 V)

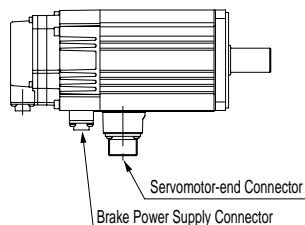

Servomotor-end Connector
For 1.0 to 5.0 kW



Capacity kW	Servomotor-end Connector (Receptacle)	Cable-end Connector (Not Provided by Yaskawa)					Applicable Cable Diameter (For Reference)	Manufacturer
		Plug	Straight Plug	L-shaped Plug	Cable Clamp			
1.0 to 2.5	CE05-2A18-10PD-D	CE05-6A18-10SD-D	CE05-6A18-10SD-D-BSS	CE05-8A18-10SD-D-BAS	CE3057-10A-1-D	10.5 dia. to 14.1 dia.	DDK Ltd.	
					CE3057-10A-2-D	8.5 dia. to 11.0 dia.		
					CE3057-10A-3-D	6.5 dia. to 8.7 dia.		
3.0 to 5.0	JL04HV-2E22-22PE-B-R	JL04V-6A22-22SE-R	JL04V-6A22SE-EB-R or JA06A-22-22S-J1-EB-R*	JL04V-8A22-22SE-EB-R or JA08A-22-22S-J1-EB-R*	JL04-2022CK(09)-R	6.5 Dia. to 9.5 Dia.	Japan Aviation Electronics Industry, Ltd.	
					JL04-2022CK(12)-R	9.5 Dia. to 13.0 Dia.		
					JL04-2022CK(14)-R	12.9 Dia. to 15.9 Dia.		

*: Not compliant with European Safety Standards, but compliant with protective structure IP67.

Brake Power Supply Connector
For 1.0 to 5.0 kW

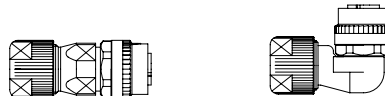

Capacity kW	Servomotor-end Connector (Receptacle)	Cable-end Connector (Not provided by Yaskawa)		
		Straight Plug	L-shaped Plug	Manufacturer
1.0 to 5.0	CM10-R2P-D	CM10-SP2S-S-D Applicable Cable: 4.0 dia. to 6.0 dia.	CM10-AP2S-S-D Applicable Cable: 4.0 dia. to 6.0 dia.	DDK Ltd.
		CM10-SP2S-M-D Applicable Cable: 6.0 dia. to 9.0 dia.	CM10-AP2S-M-D Applicable Cable: 6.0 dia. to 9.0 dia.	
		CM10-SP2S-L-D Applicable Cable: 9.0 dia. to 11.6 dia.	CM10-AP2S-L-D Applicable Cable: 9.0 dia. to 11.6 dia.	

To order a brake power supply connector kit (1.0 to 5.0 kW) with the order no. below, contact your Yaskawa representative.

J Z S P - C V B 9 - S M S2 - E

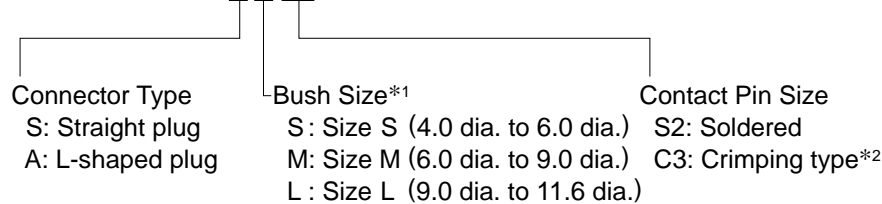

*1: A size-M connector kit is available as standard equipment.
*2: A crimp tool (model: 357J-50448T) by DDK Ltd. is required.

Selecting Cables

● Encoder Cables (Max. length: 20 m)

■ Non-Stock Items

Name	Length (L)	Order No.		Specifications	Details	
		Standard Type	Flexible Type*			
Encoder Cable with Connectors (For Incremental Encoder)	3 m	JZSP-CVP01-03-E	JZSP-CVP11-03-E	<p>SERVOPACK End Encoder End</p> <p>Connector (Crimped) (Molex Japan Co., Ltd.) CM10-SP10S-□-D (DDK Ltd.)</p>	(1)	
	5 m	JZSP-CVP01-05-E	JZSP-CVP11-05-E			
	10 m	JZSP-CVP01-10-E	JZSP-CVP11-10-E			
	15 m	JZSP-CVP01-15-E	JZSP-CVP11-15-E			
	20 m	JZSP-CVP01-20-E	JZSP-CVP11-20-E			
	3 m	JZSP-CVP02-03-E	JZSP-CVP12-03-E			<p>SERVOPACK End Encoder End</p> <p>Connector (Crimped) (Molex Japan Co., Ltd.) CM10-AP10S-□-D (DDK Ltd.)</p>
	5 m	JZSP-CVP02-05-E	JZSP-CVP12-05-E			
	10 m	JZSP-CVP02-10-E	JZSP-CVP12-10-E			
15 m	JZSP-CVP02-15-E	JZSP-CVP12-15-E				
Encoder Cable with Connectors (For Absolute Encoder, with a Battery Case)	3 m	JZSP-CVP06-03-E	JZSP-CVP26-03-E	<p>SERVOPACK End Encoder End</p> <p>Connector (Crimped)(Molex Japan Co., Ltd.) Battery Case (Battery Attached) CM10-SP10S-□-D (DDK Ltd.)</p>	(2)	
	5 m	JZSP-CVP06-05-E	JZSP-CVP26-05-E			
	10 m	JZSP-CVP06-10-E	JZSP-CVP26-10-E			
	15 m	JZSP-CVP06-15-E	JZSP-CVP26-15-E			
	20 m	JZSP-CVP06-20-E	JZSP-CVP26-20-E			
	3 m	JZSP-CVP07-03-E	JZSP-CVP27-03-E			<p>SERVOPACK End Encoder End</p> <p>Connector (Crimped)(Molex Japan Co., Ltd.) Battery Case (Battery Attached) CM10-AP10S-□-D (DDK Ltd.)</p>
	5 m	JZSP-CVP07-05-E	JZSP-CVP27-05-E			
	10 m	JZSP-CVP07-10-E	JZSP-CVP27-10-E			
15 m	JZSP-CVP07-15-E	JZSP-CVP27-15-E				
SERVOPACK-end Connector Kit		JZSP-CMP9-1-E		Soldered	(3)	
				(Molex Japan Co., Ltd.)		
Encoder-end Connectors for Protective Structure IP67 Straight Plug		JZSP-CVP9-1-E	Connector Specifications Plug: CM10-SP10S-M-D Electrical Contact: (Crimped)** CM10-#22SC(C4)-100 Applicable Cable Diameter: 6.0 dia. to 9.0 dia.	+ Electrical Contact	-	
		JZSP-CVP9-3-E	Connector Specifications Plug: CM10-SP10S-M-D Electrical Contact: (Soldered) CM10-#22SC(S1)-100 Applicable Cable Diameter: 6.0 dia. to 9.0 dia			(DDK Ltd.)
Encoder-end Connectors for Protective Structure IP67 L-shaped Plug		JZSP-CVP9-2-E	Connector Specifications Plug: CM10-AP10S-M-D Electrical Contact: (Crimped)** CM10-#22SC(C4)-100 Applicable Cable Diameter: 6.0 dia. to 9.0 dia.	+ Electrical Contact	-	
		JZSP-CVP9-4-E	Connector Specifications Plug: CM10-AP10S-M-D Electrical Contact: (Soldered) CM10-#22SC(S1)-100 Applicable Cable Diameter: 6.0 dia. to 9.0 dia			(DDK Ltd.)
Cables	3 m	JZSP-CMP09-03-E	JZSP-CSP39-03-E		(4)	
	5 m	JZSP-CMP09-05-E	JZSP-CSP39-05-E			
	10 m	JZSP-CMP09-10-E	JZSP-CSP39-10-E			
	15 m	JZSP-CMP09-15-E	JZSP-CSP39-15-E			
	20 m	JZSP-CMP09-20-E	JZSP-CSP39-20-E			

* Use flexible cables for movable sections such as robot arms.

** A crimp tool (357J-52667T) is required

Selecting Cables

(1) Wiring Specifications for Cable with Connectors (For incremental encoder)

· Standard Type

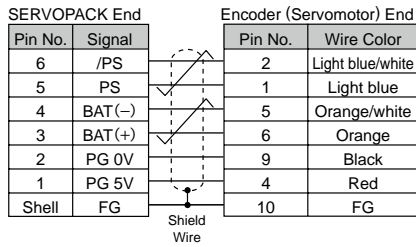

· Flexible Type

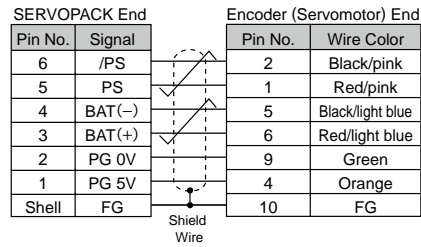

(2) Wiring Specifications for Cable with Connectors (For absolute encoder, with a battery case)

· Standard Type

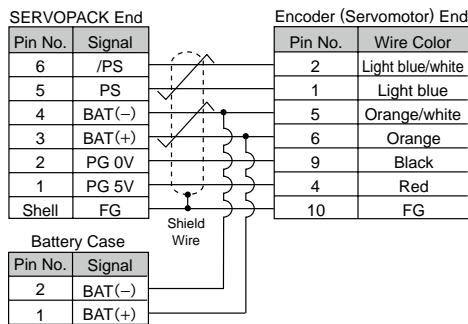

· Flexible Type

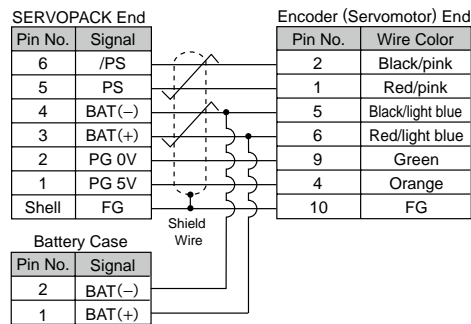

(3) SERVOPACK-end Connector Kit Specifications

Items	Specifications
Order No.	JZSP-CMP9-1-E
Manufacturer	Molex Japan Co., Ltd.
Connector Model (For standard)	55100-0670 (soldered)
External Dimensions (Units: mm)	

Note: The mating connector model on SERVOPACK: 54280-800
The mating connector model on servomotor: 55102-0600

(4) Cable Specifications

Items	Standard Type	Flexible Type
Order No.*	JZSP-CMP09-□□-E	JZSP-CSP39-□□-E
Cable Length	20 m max.	
Specifications	UL20276 (Max. rating temperature: 80°C) AWG22×2C + AWG24×2P AWG22 (0.33 mm ²) Outer diameter of insulating sheath: 1.15 dia. AWG24 (0.20 mm ²) Outer diameter of insulating sheath: 1.09 dia.	UL20276 (Max. rating temperature: 80°C) AWG22×2C + AWG24×2P AWG22 (0.33 mm ²) Outer diameter of insulating sheath: 1.35 dia. AWG24 (0.20 mm ²) Outer diameter of insulating sheath: 1.21 dia.
Finished Dimensions	6.5 dia.	6.8 dia.
Internal Configuration and Lead Color		
Yaskawa Standards Specifications (Standard Length)	Cable length: 5 m, 10 m, 15 m, 20 m	

*: Specify the cable length in □□ of order no.
Example: JZSP-CMP09-05-E (5 m)

Selecting Cables

● Encoder Cables (For extending from 30 to 50 m)

■ Limited Stock Items

Name	Length	Order No.	Specifications	Details
① Encoder-end Cables (For incremental and absolute encoder)	0.3 m	JZSP-CVP01-E		(1)
		JZSP-CVP02-E		
② Cable with Connectors (For incremental and absolute encoder)	30 m	JZSP-UCMP00-30-E		(2)
	40 m	JZSP-UCMP00-40-E		
	50 m	JZSP-UCMP00-50-E		
③ Cable with a Battery Case (For absolute encoder)	0.3 m	JZSP-CSP12-E*		(3)
④ Relay Cables	30 m	JZSP-CMP19-30-E		(4)
	40 m	JZSP-CMP19-40-E		
	50 m	JZSP-CMP19-50-E		

*: When using an incremental encoder or using an absolute encoder with a battery connected to the host controller, no battery case is required.

(1) Wiring Specifications for Encoder-end Cable
(For incremental and absolute encoder)

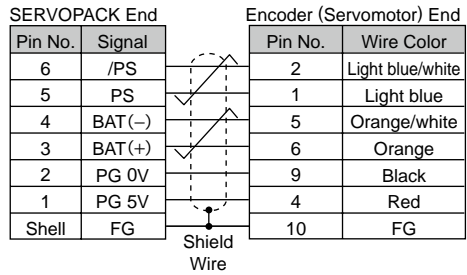

Note: The signals BAT(+) and BAT(-) are used when using an absolute encoder.

(2) Wiring Specifications for Cable with Connectors
(For incremental and absolute encoder)

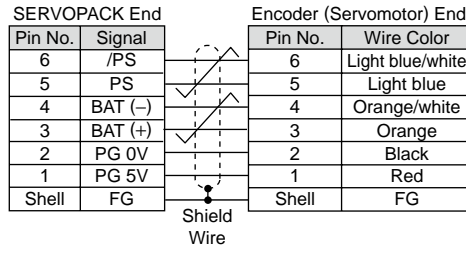

(3) Wiring Specifications for Cable with a Battery Case
(For absolute encoder)

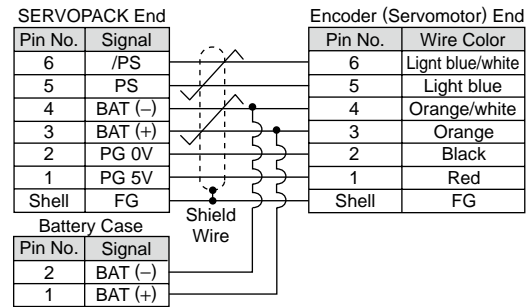

(4) Relay Encoder Cable Specifications

Item	Standard Type
Order No.*	JZSP-CMP19-□□-E
Cable Length	50 m max.
Specifications	UL20276 (Max. rating temperature: 80°C) AWG16×2C+AWG26×2P AWG16 (1.31 mm ²) Outer diameter of insulating sheath: 2.0 dia. mm AWG26 (0.13 mm ²) Outer diameter of insulating sheath: 0.91 dia. mm
Finished Dimensions	6.8 dia.
Internal Configuration and Lead Colors	
Yaskawa Standard Specifications (Standard Length)	Cable length: 30 m, 40 m, 50 m

*: Specify the cable length in □□ of order no.
Example: JZSP-CMP19-30-E (30 m)