

IMS50 Series Driver

5 Phase Stepper Driver Units

- A compact package matching most existing motors
- 100~120Vac or 200~220Vac Single Phase Power Input
- Opto-isolated inputs and outputs
- Auto-current down feature
- Half Step/Full Step setting selection



1. Specifications

Model	IMS50-110	IMS50-210	IMS50-120	IMS50-220
Power Requirement	AC100-120V±10% 50/60Hz		AC200-220V±10% 50/60Hz	
Power Consumption	400 VA max	620 VA max	500 VA max	850VA max
Drive Methods	Star Bi-polar ; constant current chopper driver			
Output Current	1.4 Amp per phase	2.8 Amp per phase	1.4 Amp per phase	2.8 Amp per phase
Resolution	Basic Step : 0.72° (1:Full Step , ½:Half Step)			
Function	Auto-current down at standstill, Auto-current OFF, MONITOR and OVERHEAT indicator outputs			
Input Signals	CW (PULSE) , CCW(CW/CCW) , CO All Opto Isolated Input resistance : 390 Ω Voltage H : 4~5V L : 0~0.5V			
CW / CCW (preferred pulse type)	<p>In Bi-Clock mode Clockwise direction pulses applied to the CW input. Counter clockwise direction pulses applied to the CCW input. Rising edge of input pulse starts to move.</p> <p>Timing chart of Bi-Clock signal</p>			
Pulse / Direction	<p>In Pulse / Direction mode Stepping pulses applied to the Pulse input. Direction logic signal applied to the CW/CCW input. Rising edge of input starts to move.</p> <p>Timing chart of Pulse/Direction signal</p> <p>[L] Level : CW [H] Level : CCW</p>			
Output Signal	MONITOR, HEAT SIGNAL output. All Opto Isolated. 25V 10mA			
Excitation Timing Output (MONI)	<p>This MONI output is activated when the driver is at origin (step zero) in the excitation sequence.</p> <p>Full Step : one pulse output at every 10 steps Half Step : one pulse output at every 20 steps</p>			

Dielectric Strength	No abnormality detected after the application of the below voltage among each terminal for one minute in normal temperature and humidity : Power input terminal – PE terminal 1.5KV Power input terminal – Signal I/O terminal 3KV
Insulation Resistance	100M ohms or higher with DC500V applied in normal temperature and humidity. • Between Voltage- input terminal Case • Between Voltage- input terminal and Signal terminal
Applicable Standard	EN60950
Operating Environment	Temperature : 0 ~ +40°C No freezing Humidity : less than 80% No condensation
Storage Environment	Temperature : -10 ~ +60°C No freezing Humidity : less than 80% No condensation
Operating Height	Less than 1,000m from sea level
Atmosphere	In the room without corrosive gas, inflammable gas or dust, without splashing water or oil.
Weight	1 Kg

2. Applicable Motor Range

Type	Motor Size (mm)	Motor Model	Max. Holding Torque (kgcm)	Rotor Inertia (gcm ²)	Basic Step Angle***	Phase Current (Amps)	Motor Weight (kg)
HI-TORQUE	60	PCE 5641 AC (BC)	4.2	175	0.72°	1.4	0.6
		PCE 5661 AC (BC)	8.3	280	0.72°	1.4	0.8
		PCE 5691 AC (BC)	16.6	560	0.72°	1.4	1.3
	85	PCE 5961 AC (BC)	21	1400	0.72°	1.4	1.7
		PCE 5991 AC (BC)	41	2700	0.72°	1.4	2.8
		PCE 59131 AC (BC)	63	4000	0.72°	1.4	3.8
HI-TORQUE *Brake Type	60	PCE 5641 ACM	4.2	320	0.72°	1.4	0.9
		PCE 5661 ACM	8.3	425	0.72°	1.4	1.1
		PCE 5691 ACM	16.6	705	0.72°	1.4	1.6
	85	PCE 5961 ACM	21	2200	0.72°	1.4	2.4
		PCE 5991 ACM	41	3500	0.72°	1.4	3.5
		PCE 59131 ACM	63	4800	0.72°	1.4	4.5
HI-TORQUE HI-SPEED	60	PCE 5692 AC (BC)	16.6	560	0.72°	2.8	1.3
	85	PCE 5962 AC (BC)	21	1400	0.72°	2.8	1.7
		PCE 5992 AC (BC)	41	2700	0.72°	2.8	2.8
		PCE 59132 AC (BC)	63	4000	0.72°	2.8	3.8
HI-TORQUE HI-SPEED *Brake Type	60	PCE 5692 ACM	16.6	705	0.72°	2.8	1.6
		PCE 5962 ACM	21	2200	0.72°	2.8	2.4
	85	PCE 5992 ACM	41	3500	0.72°	2.8	3.5
		PCE 59132 ACM	63	4800	0.72°	2.8	4.5

Note : Motor model ending with A or AC - single shaft Motor model ending with B or BC - double shaft

*** refer to resolution selection table for step angle setting

Motor Electrical Specifications

Dielectric Strength	No abnormality detected after the application of 0.5KV at 50 Hz between motor windings and frame for duration of one minute		
Insulation Resistance	100 Mohms or better with 500V potential applied between motor windings and frame at normal ambient temperature and humidity		
Insulation Class	Class B	Operating Environment Temperature	0°C ~ + 50°C

Motor Mechanical Specifications

Shaft Radial Play	0.025 mm (max) at load 0.5 Kg
Shaft Axial Play	0.075mm (max) at load 1 Kg
Step Angle Accuracy	± 3 min

IMS50-110 + PCE 5641BC

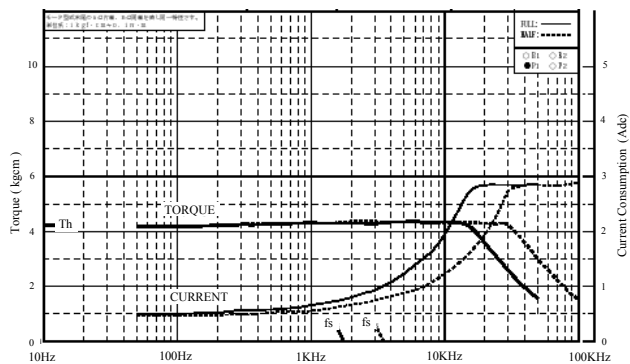

IMS50-110 + PCE 5661BC

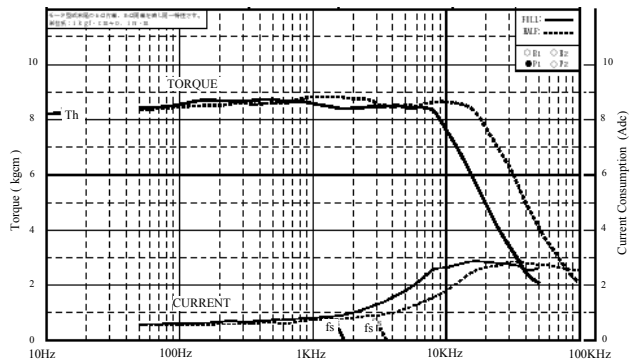

IMS50-110 + PCE 5691BC

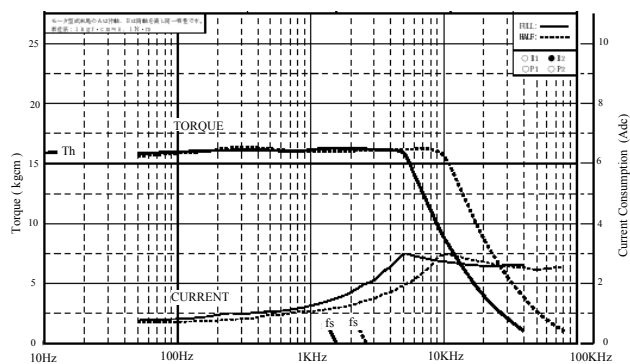

IMS50-110 + PCE 5961BC

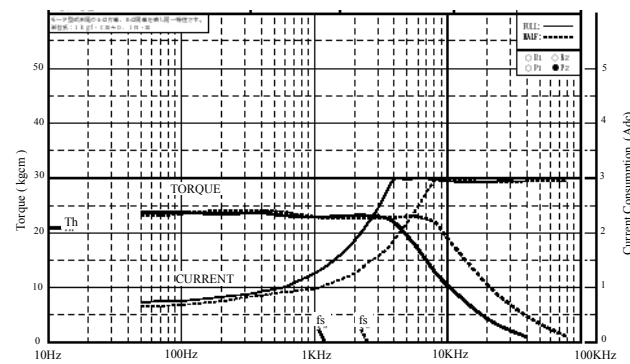

IMS50-110 + PCE 5991BC

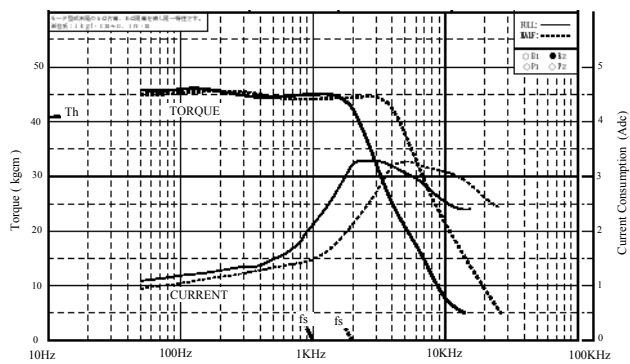

IMS50-110 + PCE 59131BC

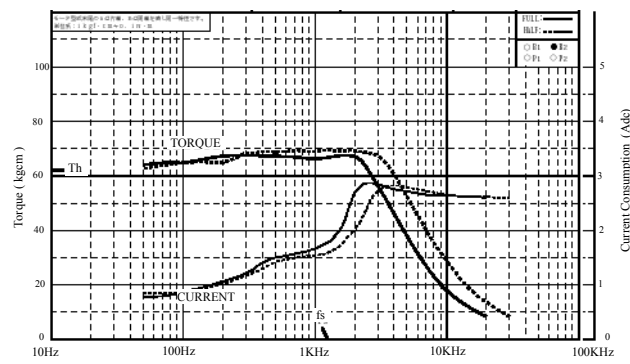

3b. Performance Characteristics - IMS 50-120 (200Vac, 1.4A series)



IMS50-120 + PCE 5641BC

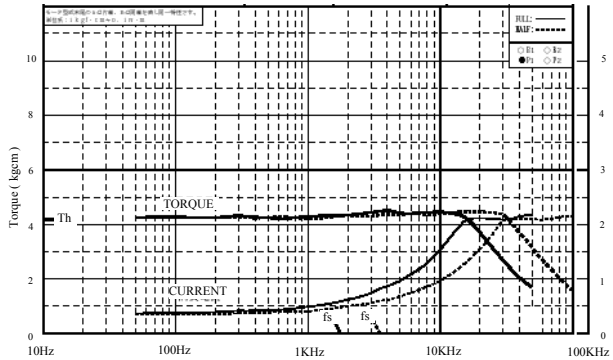

IMS50-120 + PCE 5661BC

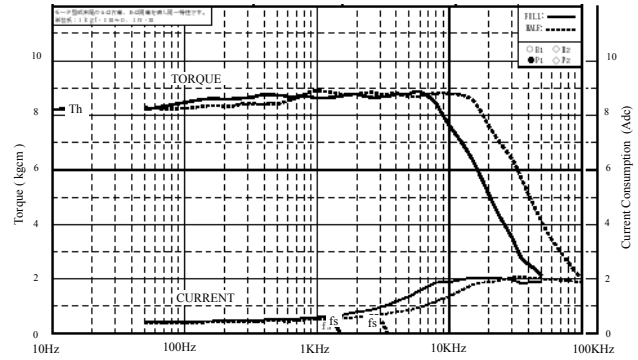

IMS50-120 + PCE 5691BC

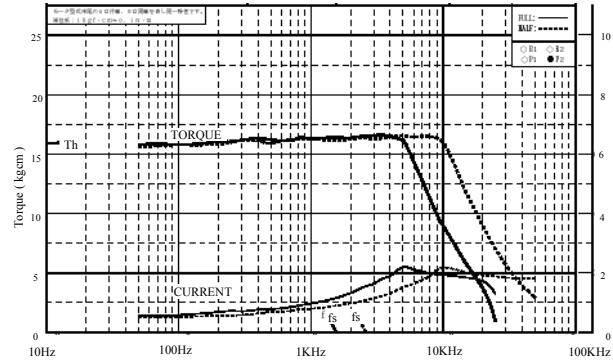

IMS50-120 + PCE 5961BC

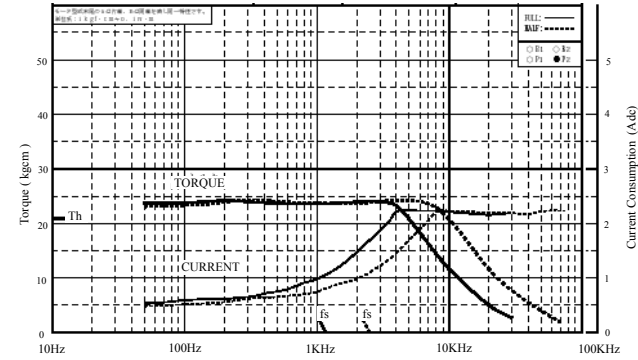

IMS50-120 + PCE 5991BC

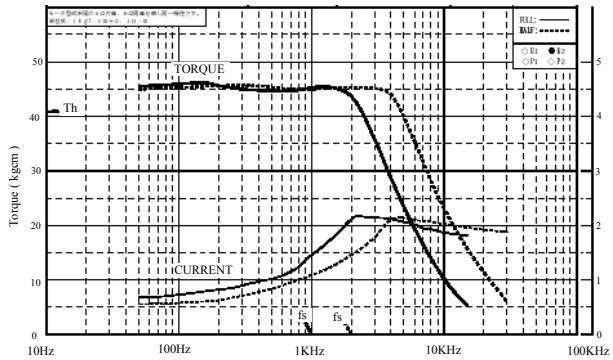

IMS50-120 + PCE 59131BC

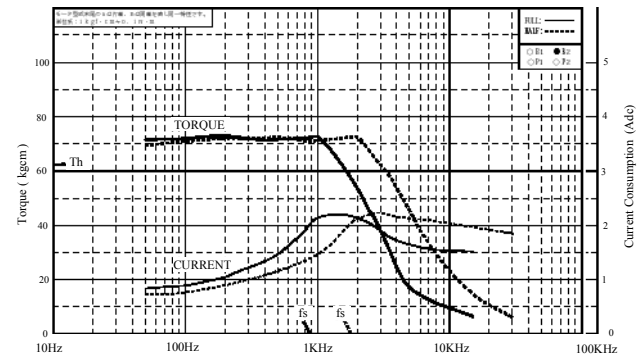

IMS50-210 + PCE 5692BC

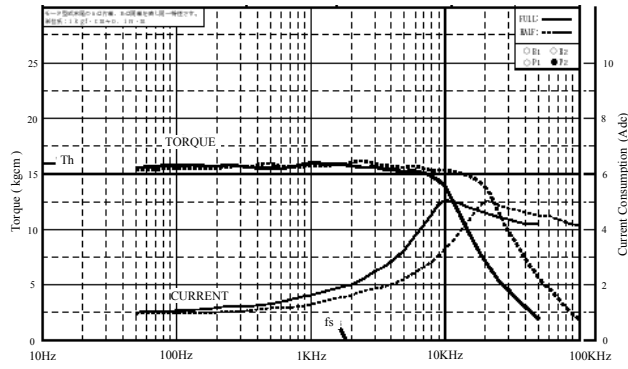

IMS50-210 + PCE 5962BC

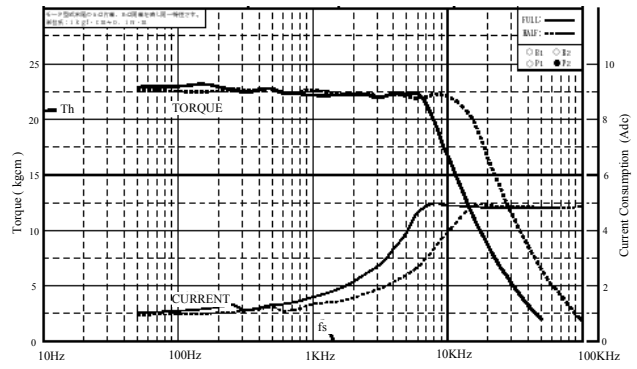

IMS50-210 + PCE 5992BC

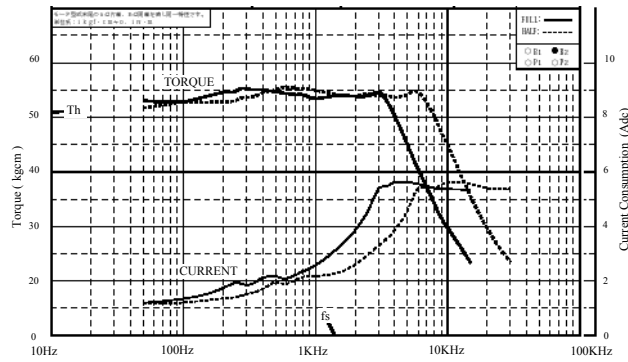

IMS50-210 + PCE 59132BC

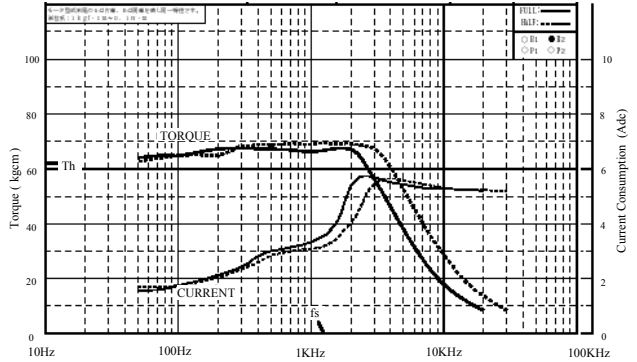

3d. Performance Characteristics - IMS 50-220 (200Vac, 2.8A series)

IMS50-220 + PCE 5692BC

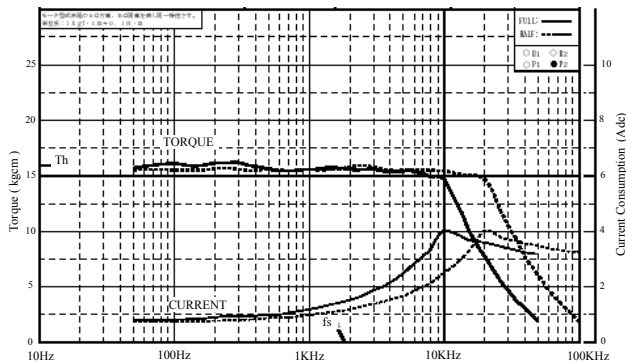

IMS50-220 + PCE 5962BC

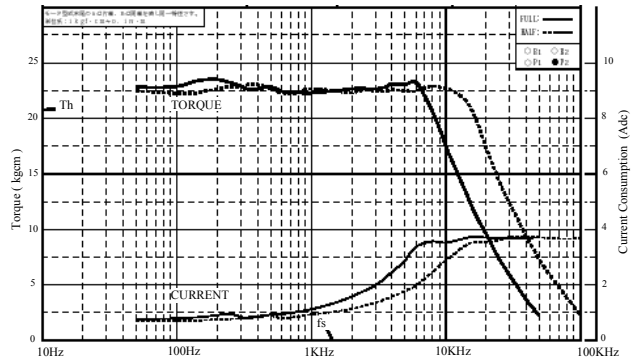

IMS50-220 + PCE 5992BC

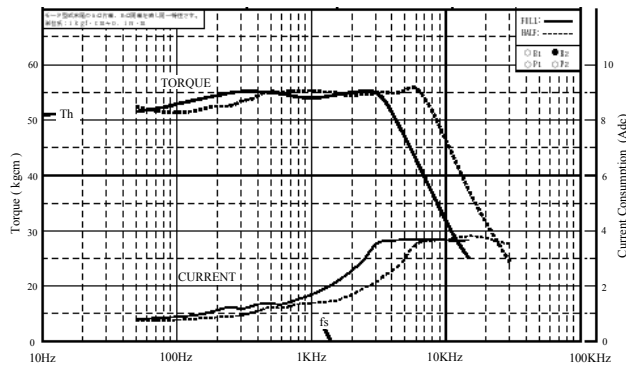

IMS50-220 + PCE 59132BC

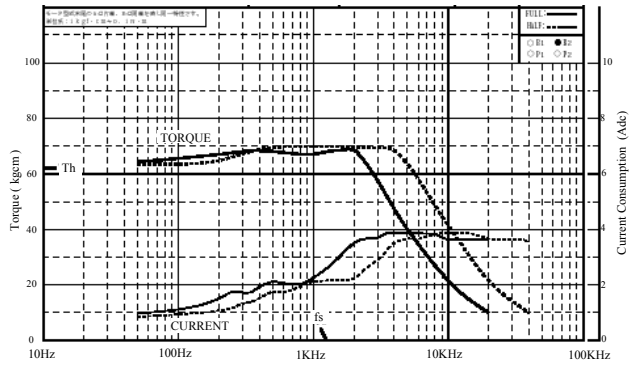

4. Part Number Identification & Default Setting

IMS 50 - 1 2 0

Series Name

- 0: BiClock (Default) , 1: Gate/Dir
- 1: 100Vac 2: 200Vac
- 1: 1.4A/phase 2: 2.8A/phase

Factory Default Setting :

Driver Model	IMS 50-110	IMS 50-210	IMS 50-120	IMS 50-220
Phase Current	1.4A	2.8A	1.4A	2.8A
Auto Current OFF (A.CO)	Disabled			
Auto Current Down (A.CD)	Enabled			
Input Pulse Signal	Bi-Clock mode (2P setting)			
Resolution	Half Step			

5. Signal Input Waveform

5-1. Input Signal Waveform

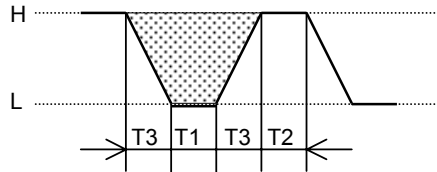

$T1 \geq 6\mu\text{sec}$
 $T2 \geq 10\mu\text{sec}$
 $T3 \leq 2\mu\text{sec}$

Shaded area shows "ON" of photo coupler at input circuit.
 The rising edge activates the motor.

6. Automatic Current Down

This driver is equipped with the auto-current down function where the motor current is reduced at stand still status. This reduces the motor heat build up when not running.

The factory setting is at 50% of the motor running current, user can adjust this setting via the CC.ADJ trimpot. The function is activated 200 msec after the motor stops. i.e. pulse input changes from H to L.. This function can be deactivated by the A.CD DIP Switch setting.

7. Connection Diagram

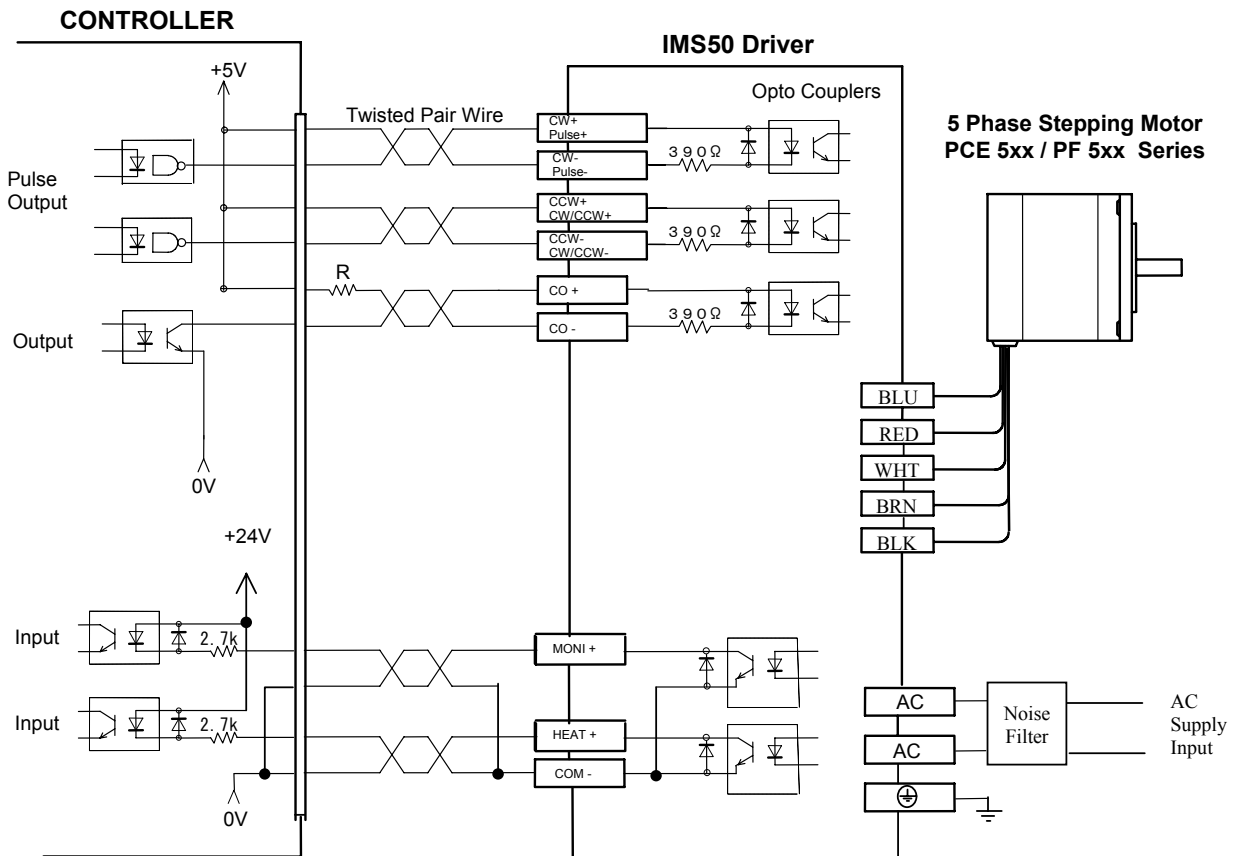

*(If controller outputs are DC24V, a resistor of value $R = 1.2k\Omega$ 1/2W is to be connected in series to the signals.
 Not necessary if the outputs are DC5V.)

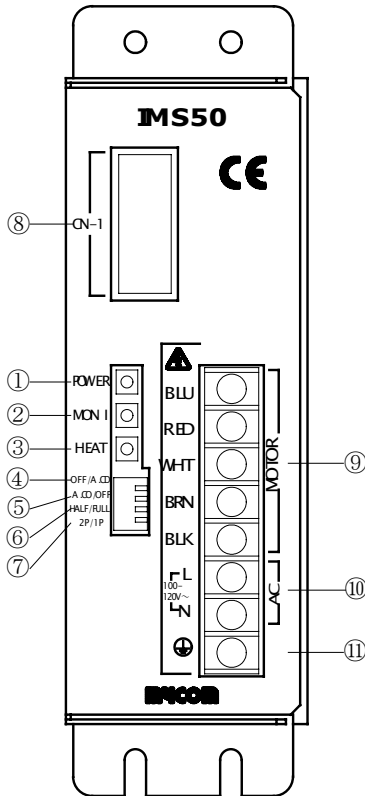

① **Power Indicator LED**

② **MONI LED**

This MONI output is activated when the driver is at origin (step zero) in the excitation sequence.
 FULL Step : one pulse output at every 10th step
 HALF Step : one pulse output at every 20th step

③ **Overheat Indicator LED**

This Overheat indicator LED lights up when the temperature sensor in the driver detected over 70°C.

④ **Auto Current Down Function (A.CD)**

This switch enables/disables the function of Auto Current Down Feature of the driver. When enabled, the motor driving current is reduced to 50% (default) (or setting as in CC.ADJ trimpot) of the motor running current. This current reduction feature helps to reduce the temperature of the motor when it is not in operation. The current down feature is activated 200 msec after the last pulse input received (determined by the non-conducting state of Clock input). **It is recommended to ENABLE this function.**

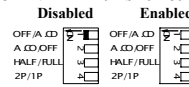

⑤ **Auto Current OFF Function (A.CO)**

This switch enables/disables the function of Auto Current Off Feature of the driver. When enabled, the motor driving current is switched OFF when the internal temperature sensor of the driver detected a temperature exceeding 70 deg Celsius.

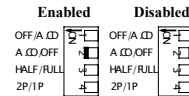

⑥ **HALF/FULL Step Selection (HALF/FULL)**

This switch selects the step angle resolution of the motor angle as follows :-
 HALF : 1000 ppr (0.36 deg / step)
 FULL : 500 ppr (0.72 deg / step)

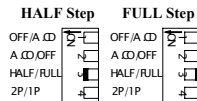

⑦ **Input Pulse Type Selection Switch (2P/1P)**

This switch sets the Type of Input Pulse for the driver.
 2P : Bi-Clock (CW, CCW clock input) – Default setting
 1P : 1 Clock (Gate / Direction input)

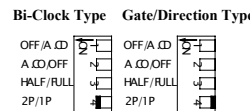

⑧ **Signal I/O connector (CN-1)**

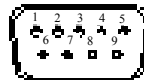

CN Driver Signal connection :-

Pin#	Driver Signal	Description	Pin#	Driver Signal	Description
1	CW+ (Pulse)	CW pulse input terminal (SW4 set to ON) This opto-isolated inputs CW pulse train from indexer.	5	CO+	Motor current shutoff input terminal (CO) The driver's output current can be turned off by this input.
2		Step / Pulse input terminal (SW4 set to OFF) This opto-isolated inputs motor step pulses from indexer.	6	CO-	The motor will not run while this input is ON.
3	CCW+ (DIR)	CCW pulse input terminal (SW4 set to ON) This opto-isolated inputs CCW pulse train from an indexer.	7	MONI+	Excitation timing output terminal. This is an open collector output which turns on once per : every 10 th pulses received (FULL step - SW3 OFF), every 20 th pulses received (HALF step - SW3 ON).
4		Direction input terminal (SW4 set to OFF) This opto-isolated inputs CW/CCW direction input.	8	HEAT+	Overheat Output terminal This is an open collector output which turns on when the driver temperature exceeds 70°C.
9	COM-	This is the common for MONI and HEAT output.			

⑨ **Motor Lead terminals (Motor power outputs)**

Connect motor leads to these terminals according to the color code.

⑩ **AC Power Input Terminal**

Connect Single phase supply to these terminals as follows :
 Model IMS50-110 / IMS50-210 : 100V~120Vac 50/60Hz
 Model IMS50-120 / IMS50-220 : 200V~220Vac 50/60Hz
 (Use AWG18 (0.75mm²) or larger leads for connection.)

⑪ **Frame Ground (PE)**

Connect to system ground point. Use AWG18 (0.75mm²) or larger leads for connection.

IMS 50-110 / IMS 50-120 External Dimensions

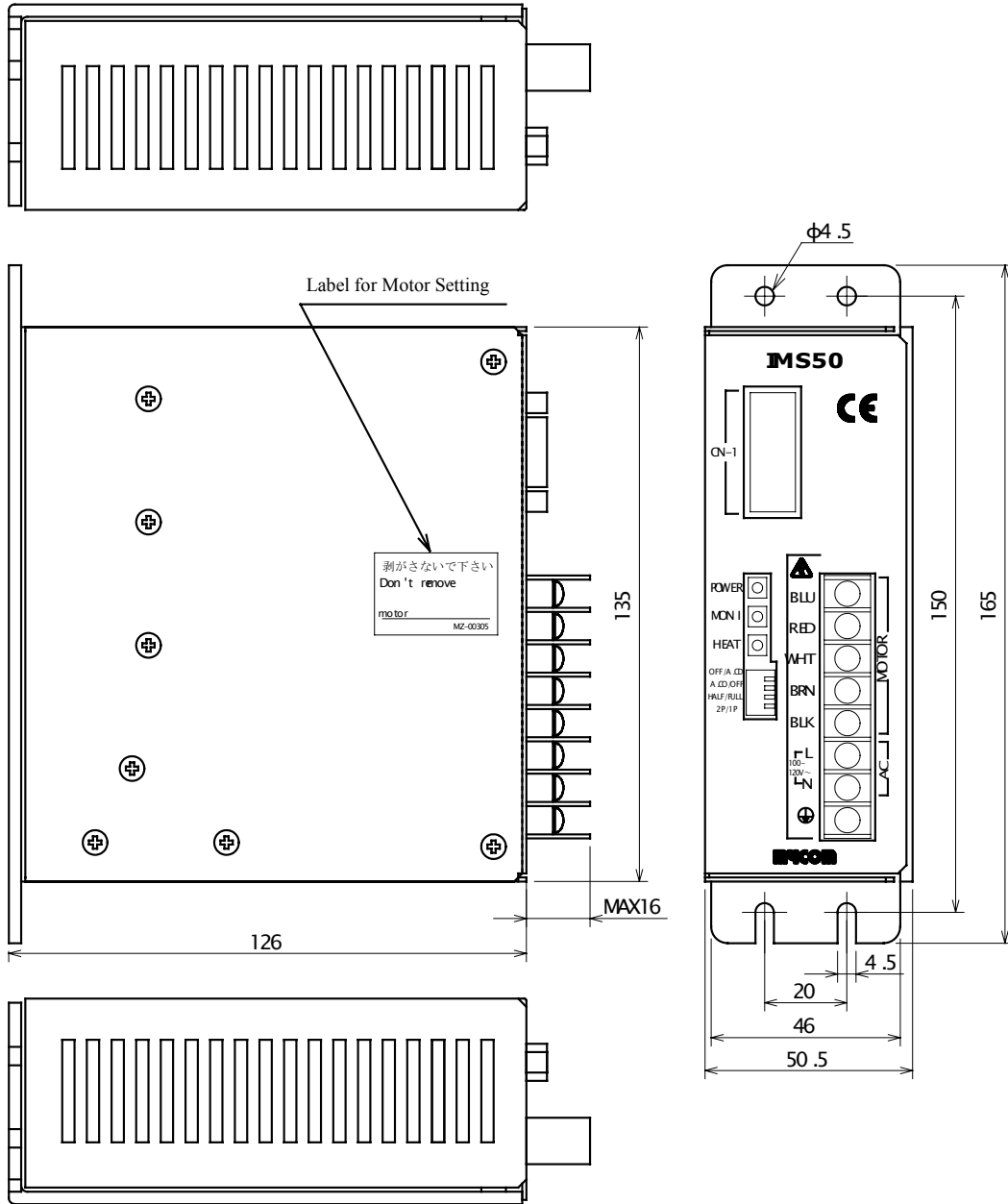

IMS 50-210 / IMS 50-220 External Dimensions

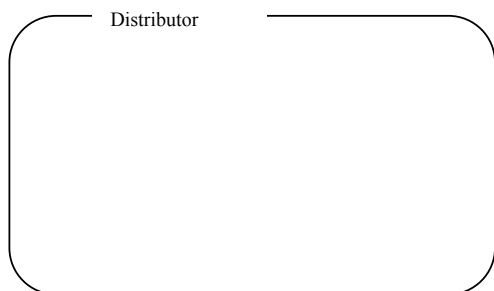
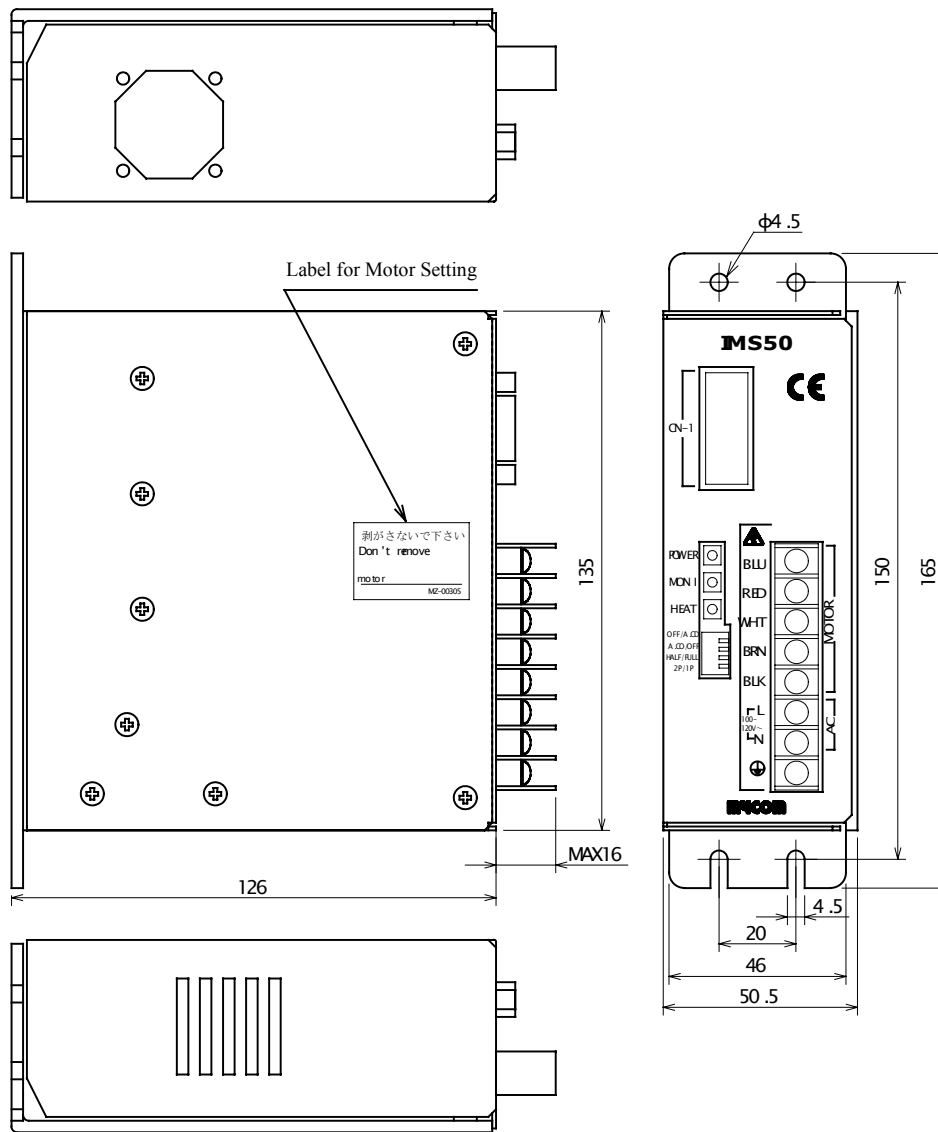

MYCOM, Inc.

12, S.Shimobano, Saga Hirosawa, Ukyo,
Kyoto 616, Japan

Tel : (81) 75-882-3601 Fax : (81) 75-880-6531
Email : support@mycom-japan.co.jp

MYCOM Technology (S) Pte Ltd

No 1 Sims Lane, #05-05 One Sims Lane
Singapore 387355

Tel : (065) 6743-4476 Fax : (065) 6743-4576
Email : sales@mycommts.com.sg

** MYCOM reserves the right to revise the specifications, dimensions etc of the above product without obligation to notify any person of such revision or changes.