

IMS20 Series Driver

2 Phase Stepping Driver Units

二相步进马达

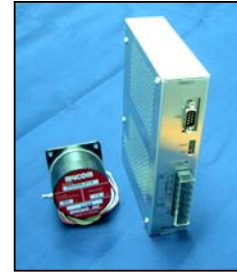

- A compact package matching most existing motors
- 100~120Vac Single Phase Power Input
- Opto-isolated inputs and outputs
- Auto-current down feature
- Half Step/Full Step setting selection

1. Specifications

Model 型号	IMS 20-210
Drive Methods 驱动方式	Bi-polar ; constant current chopper driver
Power Requirement 电源规格	Single Phase 100 ~ 120 Vac \pm 10% 50 / 60 Hz
Power Consumption 电能消耗	240 VA or less
Output Current 电流输出	2.0 Amp per phase
Resolution 分辨率	Full Step : 1.8° , Half Step : 0.9°
Function 功能	Auto-current down, Auto-current OFF, Motor Current OFF input, Excitation timing output, Overheat output
Input Signals 脉冲输入方式	CW (or Pulse) input , CCW (or Direction) input, CO (Current OFF) input Opto Isolated Input resistance : 390 Ω Input current : 8mA \leq 10mA Signal voltage H : 4 \leq 5V L : 0 \leq 0.5V
CW / CCW (preferred pulse type) 脉冲形式	In Bi-Clock mode Clockwise direction pulses applied to the CW input. Counter clockwise direction pulses applied to the CCW input. Rising edge of input pulse starts to move. Timing chart of Bi-Clock signal
Pulse / Direction 脉冲 / 方向	In Pulse / Direction mode Stepping pulses applied to the Pulse input. Direction logic signal applied to the CW/CCW input. Rising edge of input starts to move. Timing chart of Pulse/Direction signal [L] Level : CW [H] Level : CCW
Output Signal 输出信号	MONI (or Excitation timing) output , HEAT (Overheat) output Opto Isolated Open collector output : Max 25V 10mA or less
Excitation Timing Output (MONI) 励磁周期零位输出	This MONI output is activated when the driver is at origin (step zero) in the excitation sequence. Full Step : one pulse output at every 10 steps Half Step : one pulse output at every 20 steps
Dielectric Strength 电击强度	No abnormality detected after the application of the below voltage among each terminal for one minute in normal temperature and humidity : Power input terminal – PE terminal : 1.5KV (60Hz) Power input terminal – Signal I/O terminal : 3.0KV (60Hz)

Insulation Resistance 绝缘电阻	100M ohms or higher with DC500V applied in normal temperature and humidity. • Power input terminal – PE terminal • Power input terminal – signal input terminal
Operating Environment 操作环境	Temperature : 0P+40°C No freezing Humidity : less than 80% No condensation
Storage Environment 收藏环境	Temperature : -10P+60°C No freezing Humidity : less than 80% No condensation
Operating Height 操作高度	Less than 1,000m from sea level
Atmosphere 气氛	In the room without corrosive gas, inflammable gas or dust, without splashing water or oil.
Weight 重量	550 g

2. Applicable Motor Range

Type 类型	Motor Size (NEMA) 马达体型	Motor Model 马达型号	Max. Holding Torque (kgcm) 静力矩	Rotor Inertia (gcm ²) 转子惯量	Step Angle Half/Full 步矩角	Phase Current (Amps) 额定电流	Voltage (Vdc) 电压	Phase Resistance 相绝缘 (Ohms)	Motor Weight (kg) 马达重量
STANDARD (PS Series) 标准 (PS 系列)	17	PS 443-01A (B)	1.1	17	1.8°/0.9°	0.95	4.0	4.2	0.20
		PS 444-02A (B)	1.6	25	1.8°/0.9°	0.80	6.0	7.5	0.22
		PS 445-01A (B)	2.2	36	1.8°/0.9°	1.20	4.0	3.3	0.26
	23	PS 464-01A (B)	2.9	60	1.8°/0.9°	1.10	4.0	3.6	0.34
		PS 466-01A (B)	6.0	125	1.8°/0.9°	1.20	6.0	5.0	0.55
		PS 468-21A (B)	9.0	220	1.8°/0.9°	1.50	5.4	3.6	0.85
	34	PS 4610-01A (B)	10.8	350	1.8°/0.9°	1.88	6.0	3.2	1.40
		PS 496-02A (B)	12.5	560	1.8°/0.9°	1.25	5.5	4.4	1.45
		PS 499-02A (B)	22.0	1100	1.8°/0.9°	2.00	6.0	3.0	2.16
		PS 4913-02A (B)	35.0	1800	1.8°/0.9°	1.80	12.0	6.7	3.60
		PS 496M-02A (B)	12.5	560	0.9°/0.45°	1.25	5.5	4.4	1.45
		PS 499M-02A (B)	22.0	1100	0.9°/0.45°	2.00	6.0	3.0	2.60
PS 4913M-02A (B)	35.0	1800	0.9°/0.45°	1.80	12.0	6.7	3.60		
HI-TORQUE (PF Series) 高扭矩力 (PF 系列)	17	PF 445-01 A (B)	3.2	68	1.8°/0.9°	1.2	4.0	3.3	0.35
	23	PF 464-02A (B)	4.3	120	1.8°/0.9°	2.0	2.8	1.4	0.47
		PF 466-02A (B)	8.5	280	1.8°/0.9°	2.0	3.6	1.8	0.70
		PF 468-02A (B)	13.5	480	1.8°/0.9°	2.0	4.5	2.25	1.00
	34	PF 496-01A (B)	20.0	1400	1.8°/0.9°	2.0	4.4	2.2	1.75
		PF 499-01A (B)	44.0	2700	1.8°/0.9°	2.0	6.4	3.2	2.80
PF 4913-01A (B)	66.0	4000	1.8°/0.9°	2.0	7.6	3.8	3.93		

Note : Motor model ending with A - single shaft

Motor model ending with B - double shaft

Motor Electrical Specifications

Dielectric Strength 电击强度	No abnormality detected after the application of 0.5KV at 50 Hz between motor windings and frame for duration of one minute
Insulation Resistance 绝缘电阻	100 Mohms or better with 500V potential applied between motor windings and frame at normal ambient temperature and humidity
Insulation Class 绝缘等级	Class B
Operating Environment Temperature 使用环境温度	0°C ~ + 40°C

Motor Mechanical Specifications

Shaft Radial Play 轴向跳动	NEMA 17 motor	0.0006 in. (max) at 15.87 oz. force 0.015mm (max) at 450g
	NEMA 23/34 motor	0.0008 in. (max) at 15.87 oz. force 0.020mm (max) at 450g
Shaft Axial Play 轴向跳动	NEMA 17 motor	0.0008 in. (max) at 15.87 oz. force 0.020mm (max) at 450g
	NEMA 23/34 motor	0.00031 in. (max) at 15.87 oz. force 0.080mm (max) at 450g
Shaft Runout		0.0005 T.I.R. (inches) (at shaft end)
Step Angle Accuracy 步矩角的准确度		± 5% (max)
Bearing Type 轴承类型		ABEC 5P Deep Groove Permanently Sealed & Lubricated

3. Signal Input Waveform

3-1. Input Signal Waveform

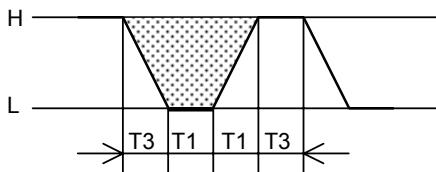

$T1 > 10\mu\text{sec}$
 $T2 > 30\mu\text{sec}$
 $T3 < 2\mu\text{sec}$
 Shaded area shows "ON" of photo coupler at input circuit.
 The rising edge activates the motor.

4. Automatic Current Down 自动电流下降

This driver is equipped with the auto-current down function where the motor current is reduced at stand still status. This reduces the motor heat build up when not running. The factory setting at 50% of the motor running current set at C.ADJ. The function is activated 250 msec after the motor stops. ie. pulse input changes from H to L.

5. Connection Diagram 接线图

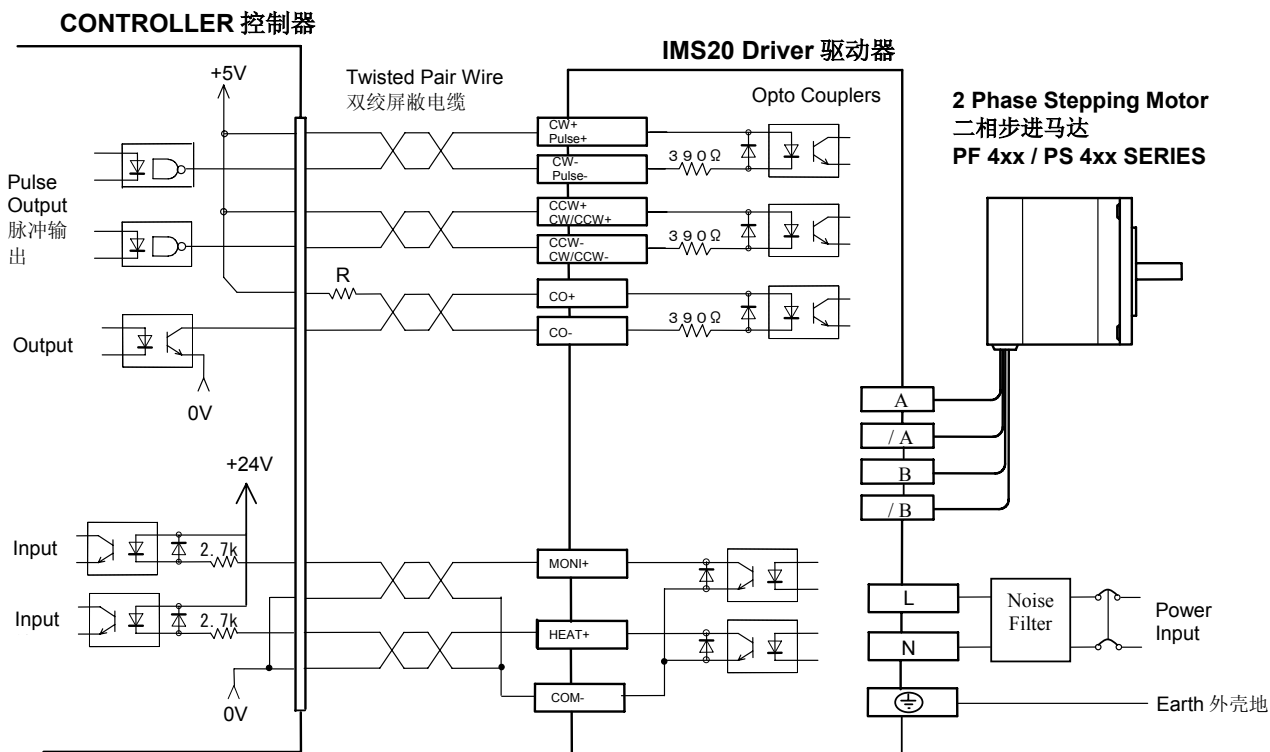

*(If controller outputs are DC24V, a resistor of value $R = 1.2k\Omega$ 1/2W is to be connected in series to the signals. Not necessary if the outputs are DC5V.)

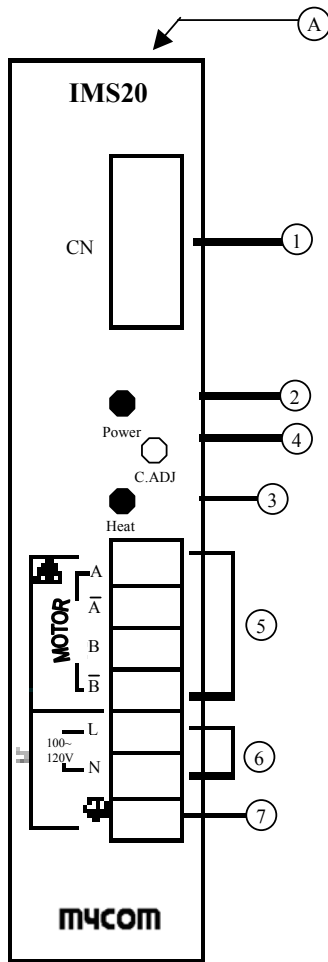

- Ⓐ **Adjustable parameters (located at top of driver) 可调整的参数**
 SW1 : 1P/2P select (OFF:1P, ON:2P)
 SW2 : Full/Half step select (OFF:Full, ON:Half)
 VR4 (CC.ADJ) : Motor Standstill Current Cut-Off adjustment

When motor is not running, motor current is reduced to this setting (20%~90%). Turning clockwise increases motor standing current, and vice versa. Factory setting at 50%. This function is activated 200ms after motor stops. This feature can be disabled by keeping CW input terminal in ON (conducting) state.

- ① **CN input/output connector (9 pin D-Sub connector)**
 ② **Power Indicator LED 电源指示灯**
 ③ **Overheat Indicator LED 驱动器过热指示灯**
 ④ **C.ADJ (Motor Running Current setting)**
 Each driver is pre-adjusted for the applicable motor included with a package. This adjustment **should not be changed** unless a lower current level setting is absolutely needed in order to reduce motor torque and motor/driver heat generation.

- ⑤ **Motor Lead terminals (Motor power outputs) 电机连接端**
 Connect motor leads to these terminals as follows :

Terminal	PS44x	PS46x / 49x	PF44x	PF46x	PF49x
A	Red	Red	Red	Red	Red
/A	White	Red/White	Blue	Red/White	Blue
B	Yellow	Green	Green	Green	Green
/B	Blue	Green/White	Black	Green/White	Black
NC	Brown	Black	White	Black	White
NC	Brown	White	Yellow	White	Yellow

* NC : no connection, tape and isolate individually

- ⑥ **AC Power Input Terminal 交流电源输入端**
 Connect Single phase 100V-120Vac 50/60Hz supply to these terminals. Use AWG18 (0.75mm²) or larger leads for connection.
 ⑦ **Frame Ground (PE) 系统保护地**
 Connect to system ground point. Use AWG18 (0.75mm²) or larger leads for connection.

CN Driver Signal connection :-

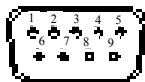

Pin No.	Driver Signal	Description
1	CW+ (Pulse)	CW pulse input terminal (SW1 set to ON) 顺时针步进信号输入端 This opto-isolated terminal accepts CW pulse train from an indexer Step / Pulse input terminal (SW1 set to OFF)
2	CW-	This opto-isolated terminal accepts motor step pulses from an indexer.
3	CCW+ (CW/CCw)	CCW pulse input terminal (SW1 set to ON) 逆时针步进信号输入端 This opto-isolated terminal accepts CCW pulse train from an indexer
4	CCW-	Direction input terminal (SW1 set to OFF) This opto-isolated terminal accepts CW/CCW direction input.
5	CO+	Motor current shutoff input terminal (CO) The driver's output current can be turned off by this input.
6	CO-	The motor will not run while this input is ON.
7	MONI	Excitation timing output terminal. 励磁周期零位输出端 This is an open collector output which turns on once per every 8 pulses received by the driver in the FULL step mode (SW2 OFF), and 16 pulses received by the driver in the HALF step mode (SW2 ON).
8	HEAT	Overheat Output terminal 过热报警输出端 This is an open collector output which turns on when the onboard temperature sensor detects the driver's heat sink temperature to exceed 70°C.
9	COM	Common for HEAT and MONI output.

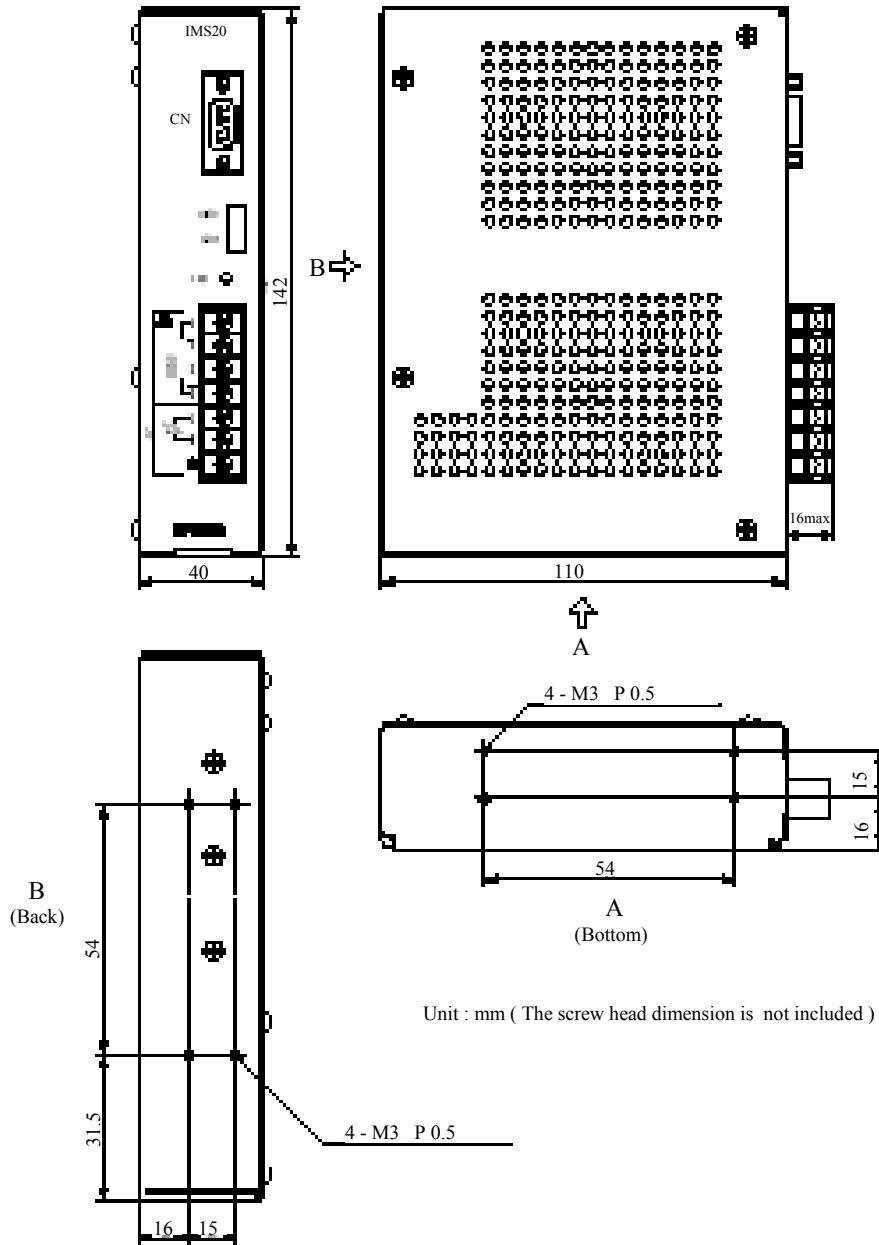

Mounting Brackets (Optional)

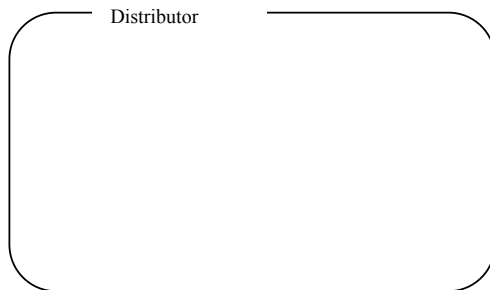
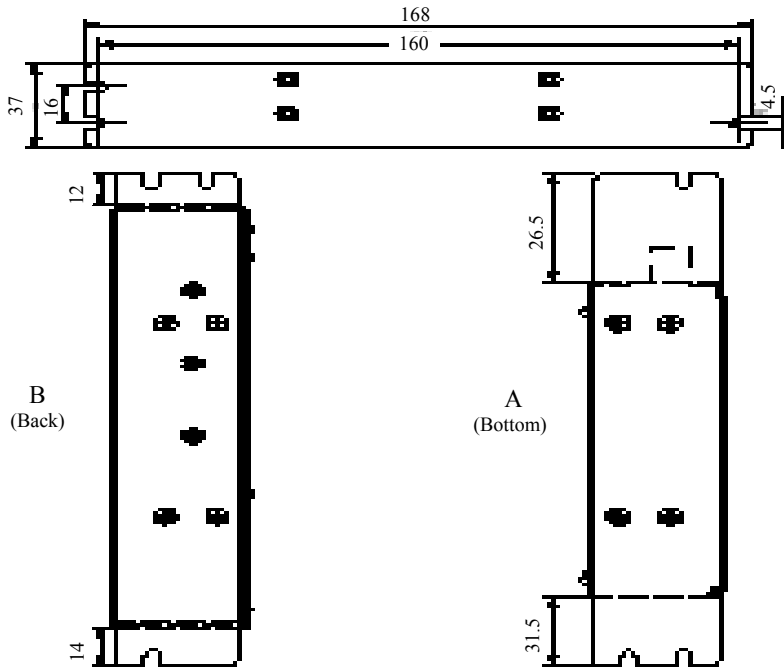

MYCOM, Inc.

12, S.Shimobano, Saga Hirosawa, Ukyo,
Kyoto 616, Japan

Tel : (81) 75-882-3601 Fax : (81) 75-880-6531
Email : support@mycom-japan.co.jp

MYCOM Technology (S) Pte Ltd

No 1 Sims Lane, #05-05 One Sims Lane
Singapore 387355

Tel : (065) 6743-4476 Fax : (065) 6743-4576
Email : sales@mycom.com.sg

** MYCOM reserves the right to revise the specifications, dimensions etc of the above product without obligation to notify any person of such revision or changes.