

LINEAR SERVO DRIVE Linear Σ SERIES

LINEAR SERVOMOTOR TYPE	CORELESS GW : SGLGW
	IRON-CORE FW : SGLFW
	IRON-CORE TW : SGLTW
SERVO DRIVER (SERVOPACK) TYPE	: SGDH

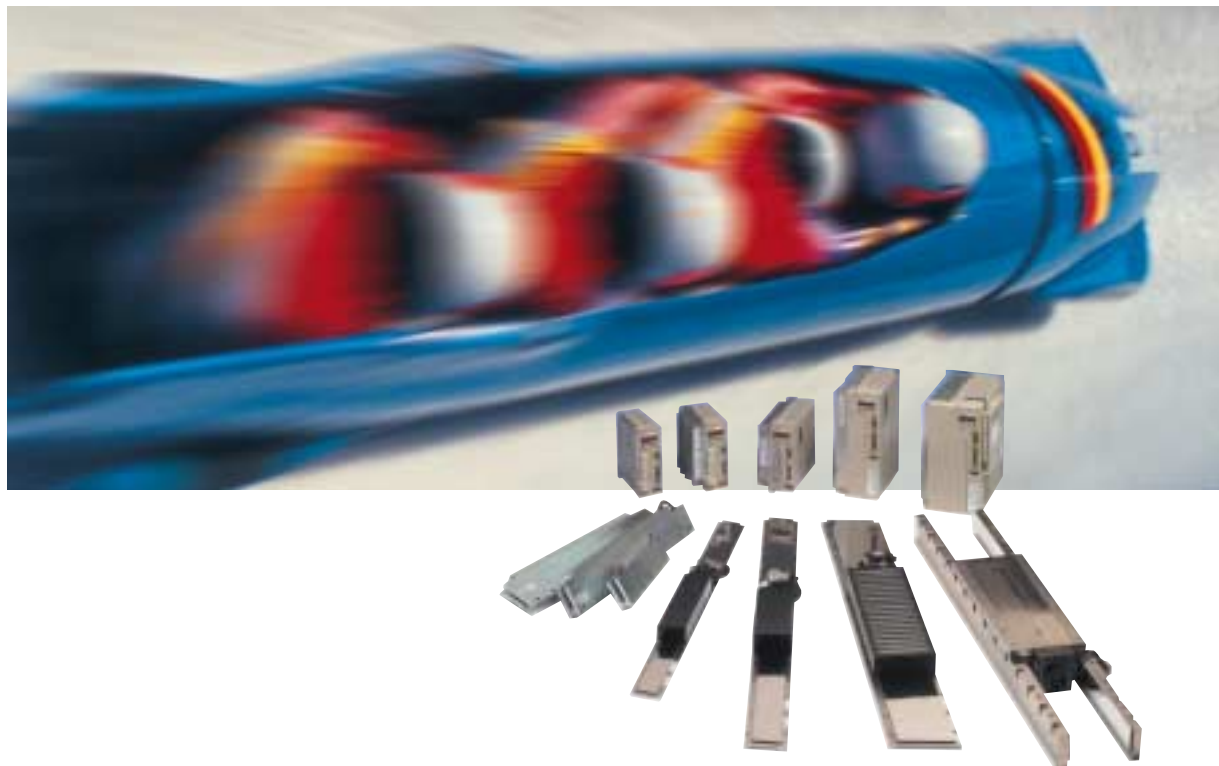

YASKAWA

Certified for
ISO9001 and
ISO14001



JQA-0422



JQA-EM0202
JQA-EM0924

Challenge for Speed

Direct drive linear servomotors for faster machine cycles.

New speed records are achieved at margins as slim as 1/100 of a second.

A finely tuned machine such as a competition sled can reach its peak speeds only when the driver's steering, weight shifting and other critical motion tasks are optimized during the trials.

Yaskawa Electric continuously challenges the performance barrier with the Linear Σ Direct Drive Servomotor products to improve the speeds and accuracies of your machines.

Backed by the company's rich technological expertise in the advanced rotary servo drive products, the Linear Σ Direct Drive Servomotors will take your machine performance to the next level into the new Millennium.

The Yaskawa Linear Σ Direct Drive Servomotors are in use to improve the reliability, speed and accuracy performance in semiconductor / LCD panel production machinery, SMD placement systems as well as virtually all types of general automation applications.

Advantages of Applying Linear Servo Drives

Improved Machine Performance

A linear motor is directly coupled to the load. This achieves high positioning accuracies and super wide operational speed ranges compared to other conventional drive/translation mechanisms. An unlimited linear travel envelope can be obtained by coupling the stationary magnet tracks as needed.

Simplified Machine Design & Construction



Since the moving member of the motor is rigid and is directly fixed to the load, the linear motion mechanism's stiffness is greatly improved. Multiples of the moving motor members can be operated independently over a single axis of the magnet track, a variety of motion can be generated from a very compact drive system.

Ease of Operation & High Reliability

Linear motors are quiet even at high speeds since the only contacting mechanisms in the linear motor system are the linear motion guides. The system reliability is increased and maintenance requirements are greatly reduced.



C O N T E N T S

	Page
● Outline	
Performances	4
Constructions and Features	6
Range of Products	8
Type Designations	9
● Linear Σ Direct Drive Servomotor Specifications	
Coreless GW (U-Channel types)	10
Iron-core FW (Flat-bed types)	14
Iron-core TW (See photo below)	22
	
● SIGMA-II Servodriver Specifications	
SGDH	30
	
● Available Options & Motor Sizing Data	34
● Ordering References	36

Performances

Force Density

The Linear Σ Direct Drive Servomotors are designed for high force density in compact packages. This is made possible by the extensive use of high-energy rare earth magnets. Combined with the cutting edge materials are Yaskawa's motor design optimization expertise and high density winding technology from the company's world-famous SIGMA & SIGMA-II rotary servo motor products.

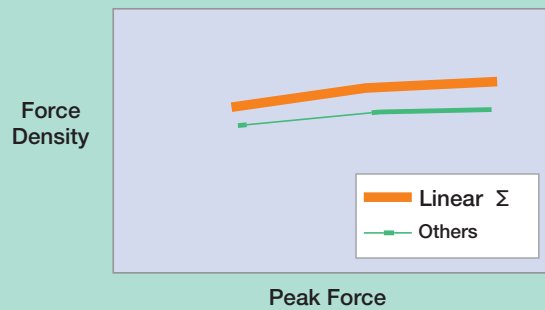

Force Linearity

The Linear Σ Direct Drive Servomotors exhibit exceptional Force Linearity even at near the peak force regions. This is achieved through the advanced magnetic circuitry, optimum winding geometry as well as the d-q axis current control method within the powerful SIGMA-II Digital Servodrivers.

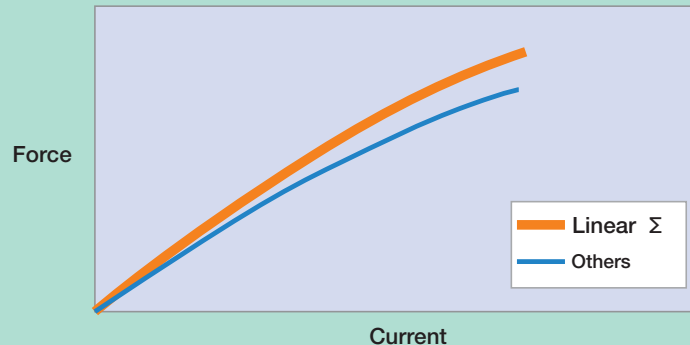

Velocity Ripple

The Linear Σ Direct Drive Servomotor performance levels are further enhanced by the combined use with SIGMA-II Digital Servodrivers. The closed loop-direct drive linear servo system generates extremely smooth linear motion with minimum velocity ripple.

Speed

The Linear Σ Direct Drive Servomotors can reach speeds as high as 5 meters (196 inches) per second. Since the direct drive linear motors do not suffer from the usual limitations of the conventional mechanical drive systems, the operational speed ranges are not constrained by factors such as the travel lengths of the linear motion systems.

Acceleration

The Linear Σ Direct Drive Servomotors can accelerate well beyond the capability of other mechanical linear translation systems.

The Linear Σ motors themselves can reach astonishing 20Gs of maximum acceleration.

Settling Time

The Linear Σ Direct Drive Servomotors combined with the SIGMA-II Servodrivers can shorten the system settling time after motion. The excellent dynamic stiffness of the Linear Σ motors and one of the fastest servodriver in the industry can immediately improve your machines' motion cycle specifications.

Magnetic Attraction Forces

The Linear Σ Type GW motors are Coreless and there is no attraction force between the motor members, and is of Zero-Cogging in nature.

The Linear Σ Type FW and TW motors are Iron-core type, and there are small to large attraction forces, depending on the size of the motor, between the moving and the stationary parts of the motors. These attraction forces can provide benefits in some systems by providing the Preload Forces to the Linear Motion Guides, increasing the system rigidity. Inversely, the attraction forces may negatively affect the mechanical design freedom since the forces acting on the relative members of the motors must be properly supported by increased bearing load capacities.

The Iron-core TW motors overcome this limitation in the Iron-core design by a patented structure where the attraction forces are negated by its unique layout. The TW motors offer the high force density and long linear bearing life in compact packages.

High Efficiency

The Linear Σ Direct Drive Servomotors are extremely energy efficient. Due to its optimized magnetic circuitry design and high-density windings inherited from the company's legendary SIGMA Servomotors, the effects of motors' heat being transferred to the other areas of your machine are minimized.

Constructions and Features

Type: Coreless GW

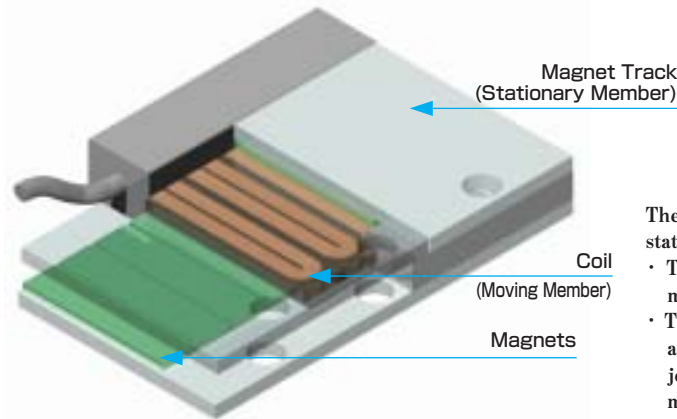

Construction

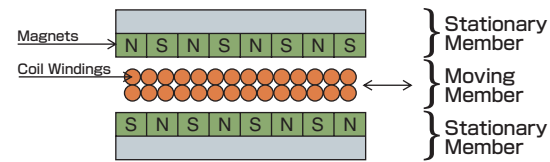

The coreless GW linear motors are composed of "Moving Coils" and stationary "Magnet Tracks".

- The moving coil has no Iron content and is made of accurately resin molded motor windings.
- The stationary magnet track is made of two nickelized steel plates with accurately placed rare-earth magnets on each side. The steel plates are jointed at one end to form a "U-Channel" to provide a space for the moving coils.

Features

- The coreless construction of the GW results in zero-attraction force, zero-cogging and no moment loads on linear motion bearings.
- The lack of attraction force helps to extend the life of linear motion guides, and the operational noise can be kept to a minimum.
- The velocity ripple is minimized due to zero-cogging nature of the coreless construction.

Type: Iron-core FW

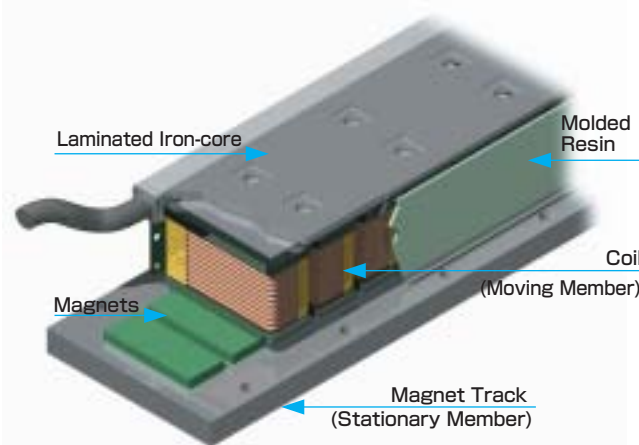

Construction

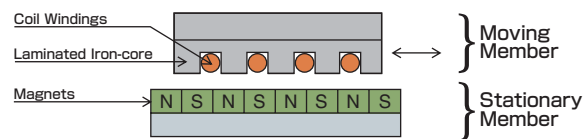

The Iron-core FW linear motors are composed of "Moving Coils" with laminated iron-core and single sided stationary "Magnet Tracks".

- The moving coil of the FW linear motors are composed of laminated iron-core and pre-wound coil bobbins inserted into the slots located on the laminated iron-cores. The entire coil unit, after the precision assembly process, is permanently encapsulated in a thermally conductive resin body to give structural rigidity.
- The magnet track of the FW is made of a row of rare-earth magnets accurately placed on one side of the nickelized steel carrier plate. Stainless-steel magnet covers against minor accidental damages protect the magnets on the FW magnet tracks.

Features

- The magnetic attraction force between the moving and stationary members can be used effectively to increase the rigidity of the linear guidance system by pre-loading the linear motion bearings.
- The magnetic pre-loading on certain types of compliant linear motion bearings can help increase the system's frequency response, improving its deceleration and settling performances.
- The compact profiles of the FW linear motors result in low profile linear positioning systems.

Type: Iron-core TW

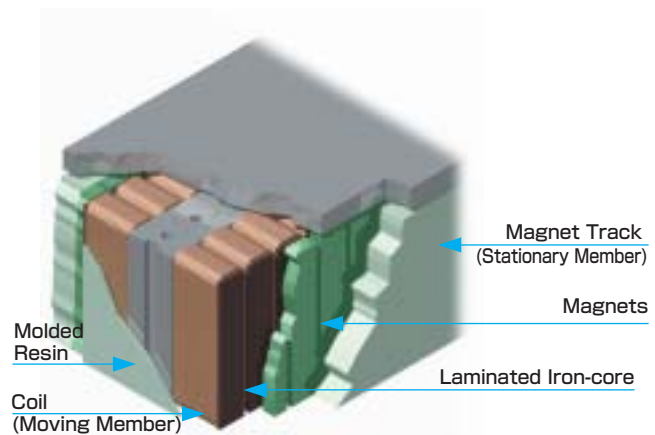

Construction

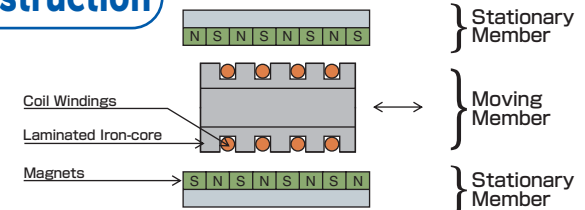

The Iron-core TW linear motors are composed of "Moving Coils" with laminated iron-core and a pair of stationary "Magnet Tracks" that are placed on each side of the moving coils.

- The moving coil of the TW linear motors are composed of laminated iron-core and pre-wound coil bobbins inserted into the slots located on the laminated iron-cores. The entire coil unit, after the precision assembly process, is permanently encapsulated in a thermally conductive resin body to give structural rigidity.
- The magnet track of the TW is made of a row of rare-earth magnets accurately placed on one side of the nickelized steel carrier plate. Two of the magnet carrier plates are used as a pair in a fashion similar to that of the Coreless type motors. Stainless-steel magnet covers against minor accidental damages protect the magnets on the TW magnet tracks.

Features

- Yaskawa's unique construction principles of the TW linear motors negate the effects of magnetic attraction force between the relative motor members. This provides for the use of smaller linear motion bearing systems without major concerns in the linear motion bearing life.
- The linear motion bearing run quieter due to the lack of attraction force.
- The TW linear motors have very little cogging due to its optimized internal magnetic circuit design.

Linear Σ Application Notes

- 1 In order to obtain the maximum motor performance, and to avoid the relative contacting of the motor components, the air-gap between the moving coil and the magnet track must be maintained according to the specified dimensional tolerances.

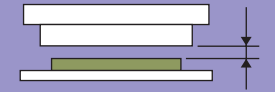

- 2 The iron-core motors typically have the attraction forces that are 5~6 times that of motors' own peak forces (except for the TW linear motors). Therefore, it is extremely important to design rigid mechanical structure around the iron-core linear motors as well as taking extra care in selecting the linear motion bearings with sufficient load capacities. Since the linear motors are capable of very high terminal linear velocities, be sure to check for the maximum speed limitations on the linear motion bearings selected for the system.

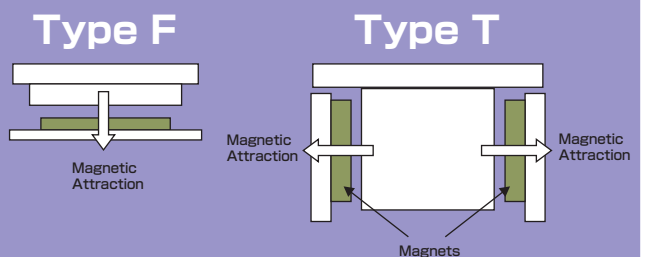

- 3 Avoid foreign materials to fall into the air-gap of linear motors. Employ general cautions regarding the environmental conditions.

- 4 When the linear motors are intended for use in vertical load orientation, well designed counterbalancing or mechanical braking mechanisms must be provided in order to avoid the load to free-fall when the motor is no longer "In-Servo" mode.

- 5 The moving motor coil and the linear encoder read-head should be placed as close as practically possible in order to obtain the best system accuracy. However, the effects of the heat generated by the motor must be taken into consideration. Excessive heat transfer from the motor coil to the linear encoder read-head will cause degradation of reliability as well as malfunction of the feedback system.

- 6 The linear servomotor coils generate heat. The heat management consideration is critical in a linear motor based positioning systems design.

Range of Products

Linear Σ Servomotors		SIGMA-II Servodrivers (SERVOPACK)		
		SGDH		
		208~240VAC		
		Single-phase	Three-phase	
Coreless GW		40A140	●	
		60A140	●	
		40A253	●	
		40A365	●	
		60A253	●	
		60A365		●
Iron-core FW		20A090	●	
		20A120	●	
		35A120	●	
		35A230		●
		50A200		●
		50A380		●
		1ZA200		●
		1ZA380		●
Iron-core TW		20A170		●
		20A320		●
		20A460		●
		35A170		●
		35A320		●
		35A460		●
		40A400		●
		40A600		●
		80A400		●
		80A600		●

Type Designation

1N=0.2276 lbs.=0.102kgf
1kg=2.232 lbs.
1mm=0.03937 in.

Linear Σ Servomotors

Moving Coils

SGLGW-40A140AW

Linear Σ series servomotors

Model

- G: Coreless GW
- F: Iron-core FW
- T: Iron-core TW

W: Moving Coils

Height of Magnets

Voltage

A: 208~240VAC

W: With a Hall Sensor module and a Serial Converter module. (standard stock configuration). The Serial Converter is required for operation with SIGMA-II drives.

P: With a Hall Sensor module only, without a Serial Converter (when ordering for a replacement motor coil only). Always use "W" for normal orders.

Design Revision Order

Coil Length

Magnet Tracks

SGLGM-40225AC

Linear Σ series servomotors

Model

- G: Coreless GM
- F: Iron-core type FM
- T: Iron-core type TM

M: Magnet Track

Option (Standard on Iron-core F & T types only)
C: With magnet covers
Y: With base and magnet covers

Design Revision Order

Length of Magnets
Tracks in mm
(See drawings on later pages)

Height of Magnets
20: 20mm
35: 35mm
40: 40mm
50: 50mm
60: 60mm
80: 80mm

Standard SIGMA-II Servodrivers (SERVOPACK)

SGDH

SGDH-10AE

SGDH Servodrivers

Maximum Applicable Servomotor Capacity

Code	Capacity (kW)	Code	Capacity (kW)
01	0.1	15	1.5
02	0.2	20	2.0
04	0.4	30	3.0
05	0.45	50	5.0
08	0.75	75	7.5
10	1.0		

Model

E: Force/speed/position control
(Option units available)

Power Requirements
A: 208~240VAC

Linear Σ Servomotor Specifications

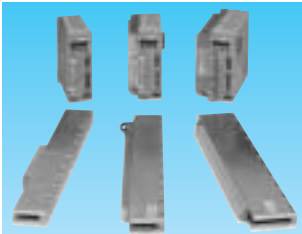

Coreless GW SGLGW-40A

Basic Specifications

- Duty Rating : Continuous
- Insulation Resistance : 500VDC 10M Ω or more
- Ambient Temperature : 0 to 40 $^{\circ}$ C
- Motor Type : Sinusoidally commutated permanent magnet brushless linear motor
- Insulation Dielectric Voltage : 1500VAC 1min.
- Cooling Method : Self/forced air
- Ambient Humidity : 20 to 80% (non-condensing)
- Allowable Winding Temperature : 130 $^{\circ}$ C (Class B)

Ratings and Specifications

Linear Servomotor Type	SGLGW-[]	40A		
		140B[]	253B[]	365B[]
Continuous Force *	N	47	93	140
Continuous Current *	Arms	0.8	1.6	2.4
Peak Force *	N	140	280	420
Peak Current *	Arms	2.4	4.9	7.3
Moving Coil Mass	kg	0.39	0.65	0.91
Force Constant	N/Arms	61.5	61.5	61.5
BEMF Constant	V/(m/s)	20.5	20.5	20.5
Motor Constant	N/ \sqrt{W}	7.8	11.0	13.5
Electrical Time Constant	ms	0.4	0.4	0.4
Mechanical Time Constant	ms	6.41	5.37	5.0
Thermal Resistance (With Heatsink)	K/W	1.87	0.98	0.65
Thermal Resistance (Without Heatsink)	K/W	3.39	2.02	1.38
Magnetic Attraction Force	N	0	0	0

Note : The above values are with aluminum heatsink (140B:200 \times 300 \times 12mm, 253B:300 \times 400 \times 12mm, 365B:400 \times 500 \times 12mm) mounted to the motor coil. Values marked with asterisks (*) apply when the linear motor is driven from SIGMA-II servodrivers at 20 $^{\circ}$ C, and the coil temperature is at 100 $^{\circ}$ C.

Force vs. Speed Characteristics ([A] : Continuous Duty Zone [B] : Intermittent Duty Zone)

SGLGW-40A140B[]

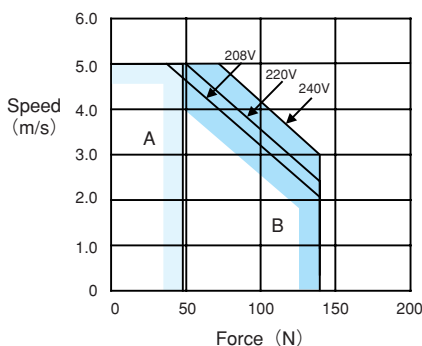

SGLGW-40A253B[]

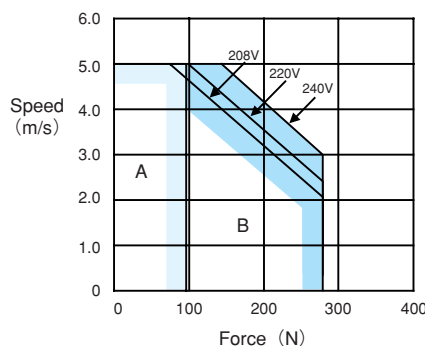

SGLGW-40A365B[]

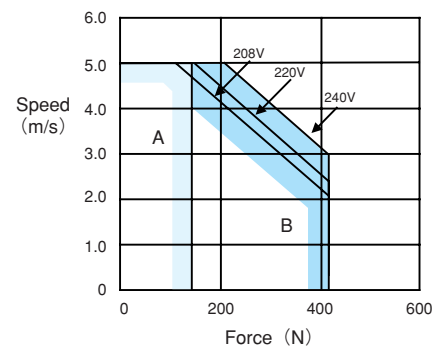

1N=0.2276 lbs.=0.102kgf
 1kg=2.232 lbs.
 1mm=0.03937 in.

Dimensions in mm DXF & DWG drawing files available.

● Moving Coil (SGLGW-40A□□□B□)

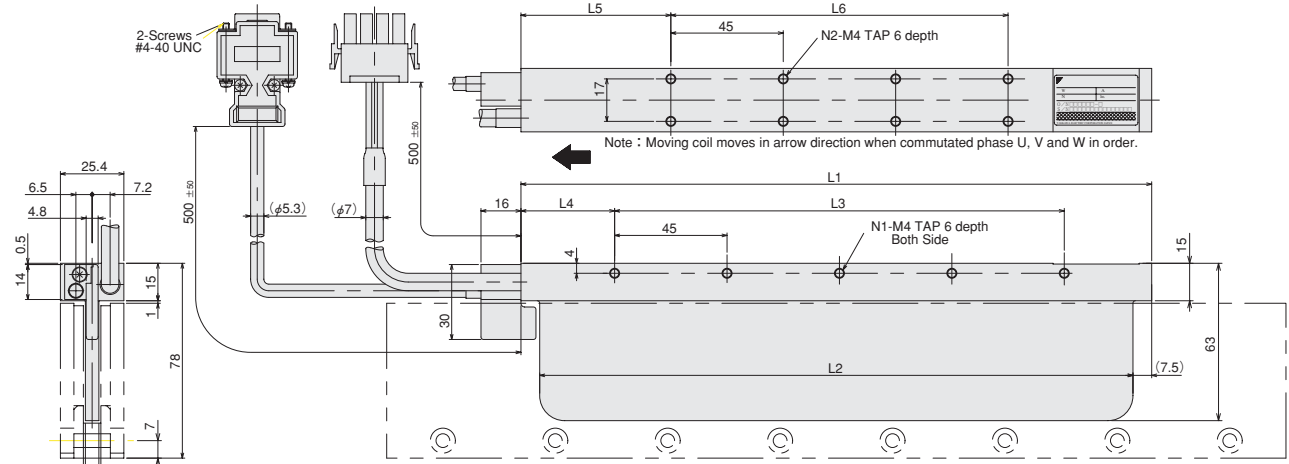

Gap 0.8

Connector for Hall Sensor

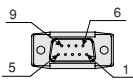

Pin Type
 Connector : 17JE-23090-02 (D8C)
 Daiichi Electronic Industries Co., Ltd.
 Mating Types
 Socket Type
 Connector : 17JE-13090-02 (D8C)
 Stud : 17L-002C or 17L-002C1

Pin No.	Name
1	+5V (Power supply)
2	Phase U
3	Phase V
4	Phase W
5	0V (Power supply)
6	—
7	—
8	—
9	—

Connector for Motor



Plug : 350779-1 AMP
 Pin : 350561-3 or 350690-3 (No.1 to 3)
 350654-1
 350669-1 (No.4)
 Mating Type
 Cap : 350780-1
 Socket : 350570-3 or 350689-3

Pin No.	Name	Color
1	Phase U	Red
2	Phase V	White
3	Phase W	Blue
4	FG	Green

Hall Sensor Output Signal

When the moving coil is moved toward the arrow in the diagram, the relation between the hall sensor's output signals (Su, Sv, Sw) and BEMF of each phase of the motor is as shown in the graph.

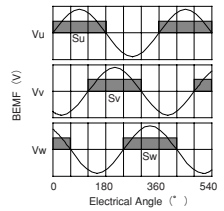

Moving Coil Type SGLGW-□□□□	L1	L2	L3	L4	L5	L6	N1	N2	Mass kg
40A140B□	140	125	90	30	52.5	45	3	4	0.39
40A253B□	252.5	237.5	180	37.5	60	135	5	8	0.65
40A365B□	365	350	315	30	52.5	270	8	14	0.91

● Magnet Track (SGLGM-40□□□□B)

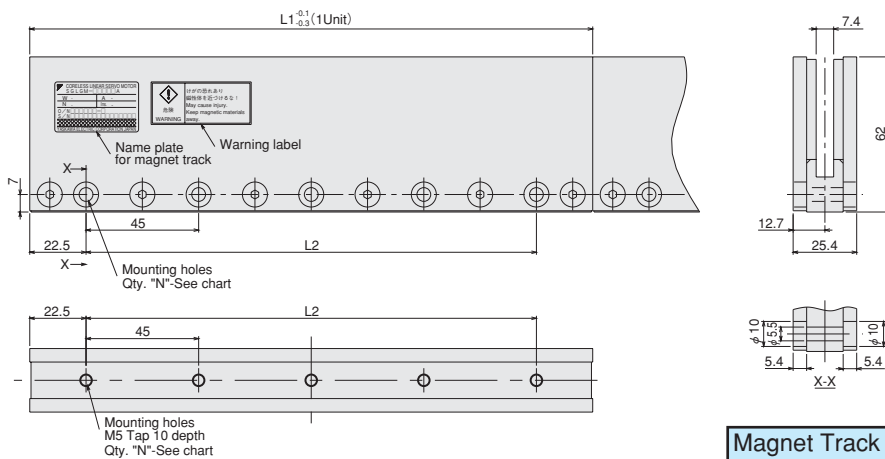

Magnet Track Type SGLGM-□□□□	L1	L2	N	Mass kg
40090B	90	45	2	0.8
40225B	225	180	5	2.0
40360B	360	315	8	3.1
40405B	405	360	9	3.5
40450B	450	405	10	3.9

Linear Σ Servomotor Specifications

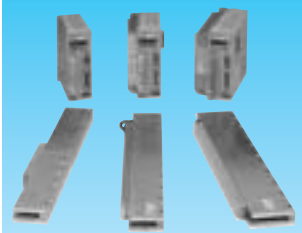

Coreless GW SGLGW-60A

Basic Specifications

- Duty Rating : Continuous
- Insulation Resistance : 500VDC 10M Ω or more
- Ambient Temperature : 0 to 40 $^{\circ}$ C
- Motor Type : Sinusoidally commutated permanent magnet brushless linear motor
- Insulation Dielectric Voltage : 1500VAC 1min.
- Cooling Method : Self/forced air
- Ambient Humidity : 20 to 80% (non-condensing)
- Allowable Winding Temperature : 130 $^{\circ}$ C (Class B)

Ratings and Specifications

Linear Servomotor Type	SGLGW-[]	60A		
		140B[]	253B[]	365B[]
Continuous Force *	N	73	147	220
Continuous Current *	Arms	1.2	2.3	3.5
Peak Force *	N	220	440	660
Peak Current *	Arms	3.5	7.0	10.5
Moving Coil Mass	kg	0.47	0.80	1.13
Force Constant	N/Arms	66.6	66.6	66.6
BEMF Constant	V/(m/s)	22.2	22.2	22.2
Motor Constant	N/ \sqrt{W}	11.1	15.7	19.2
Electrical Time Constant	ms	0.5	0.5	0.5
Mechanical Time Constant	ms	3.81	3.25	3.07
Thermal Resistance (With Heatsink)	K/W	1.62	0.80	0.53
Thermal Resistance (Without Heatsink)	K/W	2.69	1.54	1.20
Magnetic Attraction Force	N	0	0	0

Note :The above values are with aluminum heatsink (140B:200 \times 300 \times 12mm, 253B:300 \times 400 \times 12mm, 365B:400 \times 500 \times 12mm) mounted to the motor coil. Values marked with asterisks (*) apply when the linear motor is driven from SIGMA-II servodrivers at 20 $^{\circ}$ C, and the coil temperature is at 100 $^{\circ}$ C.

Force vs. Speed Characteristics ([A] : Continuous Duty Zone [B] : Intermittent Duty Zone)

SGLGW-60A140B[]

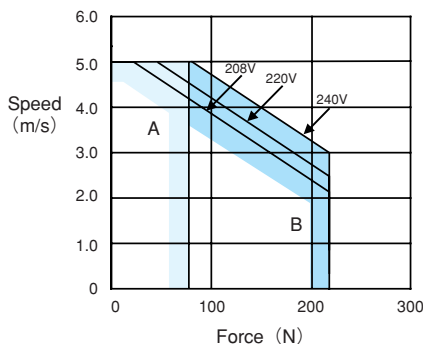

SGLGW-60A253B[]

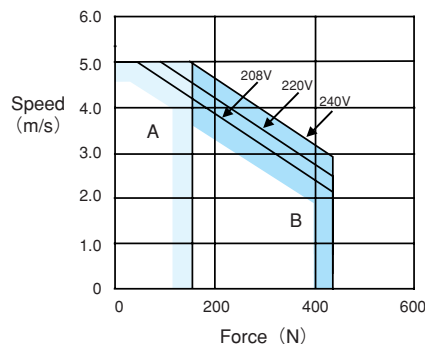

SGLGW-60A365B[]

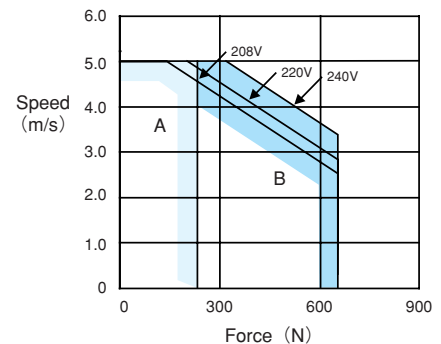

1N=0.2276 lbs.=0.102kg
 1kg=2.232 lbs.
 1mm=0.03937 in.

Dimensions in mm DXF & DWG drawing files available.

● Moving Coil (SGLGW-60A□□□A□)

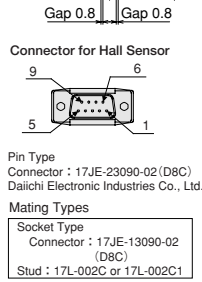
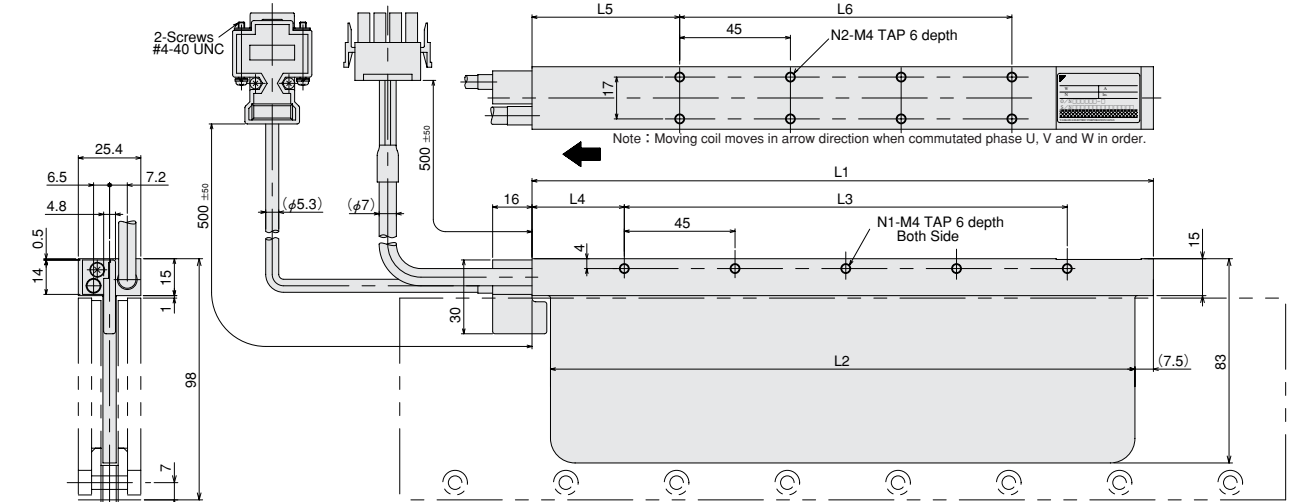

Pin No.	Name
1	+5V (Power supply)
2	Phase U
3	Phase V
4	Phase W
5	0V (Power supply)
6	—
7	—
8	—
9	—

Connector for Motor

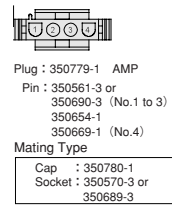

Pin No.	Name	Color
1	Phase V	Red
2	Phase U	White
3	Phase W	Blue
4	FG	Green

Hall Sensor Output Signal

When the moving coil is moved toward the arrow in the diagram, the relation between the hall sensor's output signals (Su, Sv, Sw) and BEMF of each phase of the motor is as shown in the graph.

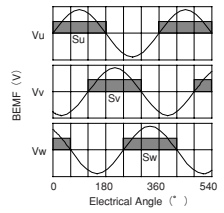

Moving Coil Type SGLGW-□□□□	L1	L2	L3	L4	L5	L6	N1	N2	Mass kg
60A140B□	140	125	90	30	52.5	45	3	4	0.47
60A253B□	252.5	237.5	180	37.5	60	135	5	8	0.80
60A365B□	365	350	315	30	52.5	270	8	14	1.13

● Magnet Track (SGLGM-60□□□A)

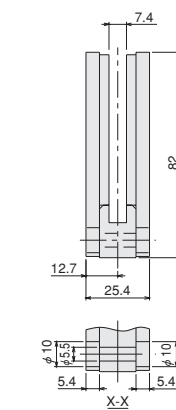
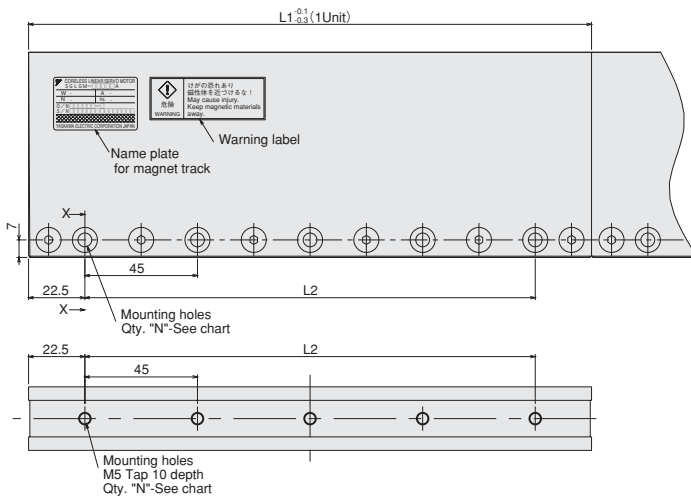

Magnet Track Type SGLGM-□□□□	L1	L2	N	Mass kg
60090B	90	45	2	1.0
60225B	225	180	5	2.6
60360B	360	315	8	4.1
60405B	405	360	9	4.6
60450B	450	405	10	5.1

Outline

Linear Servomotor

SERVOPACK

Linear Σ Servomotor Specifications



Iron-core FW SGLFW-20A

Basic Specifications

- Duty Rating : Continuous
- Insulation Resistance : 500VDC 10M Ω or more
- Ambient Temperature : 0 to 40 $^{\circ}$ C
- Motor Type : Sinusoidally commutated permanent magnet brushless linear motor
- Insulation Dielectric Voltage : 1500VAC 1min.
- Cooling Method : Self
- Ambient Humidity : 20 to 80% (non-condensing)
- Allowable Winding Temperature : 130 $^{\circ}$ C (Class B)

Ratings and Specifications

Linear Servomotor Type SGLFW-□□□		20A	
		090A□	120A□
Continuous Output *	W	125	140
Continuous Force *	N	25	40
Continuous Current *	Arms	0.7	0.8
Peak Force *	N	86	125
Peak Current *	Arms	3.0	2.9
Moving Coil Mass	kg	0.7	0.9
Force Constant	N/Arms	36.0	54.0
BEMF Constant	V/(m/s)	12.0	18.0
Motor Constant	N/ \sqrt{W}	7.9	9.8
Electrical Time Constant	ms	3.2	3.3
Mechanical Time Constant	ms	11.1	9.3
Thermal Resistance (With Heatsink)	K/W	4.35	3.19
Thermal Resistance (Without Heatsink)	K/W	7.69	5.02
Magnetic Attraction Force	N	314	462

Note : The above values are with aluminum heatsink (125 × 125 × 13mm) mounted to the motor coil. Values marked with asterisks (*) apply when the linear motor is driven from SIGMA-II servodrivers at 20 $^{\circ}$ C, and the coil temperature is at 100 $^{\circ}$ C.

Force vs. Speed Characteristics (A : Continuous Duty Zone B : Intermittent Duty Zone)

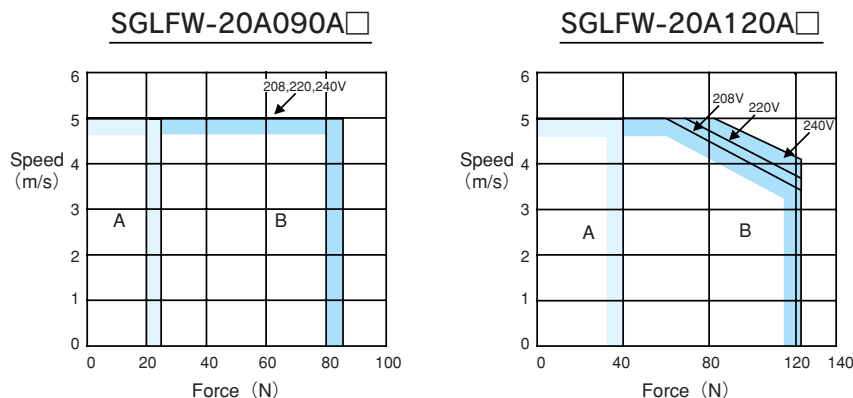

1N=0.2276 lbs.=0.102kgf
 1kg=2.232 lbs.
 1mm=0.03937 in.

Dimensions in mm DXF & DWG drawing files available.

● Moving Coil (SGLFW-20A□□□A□)

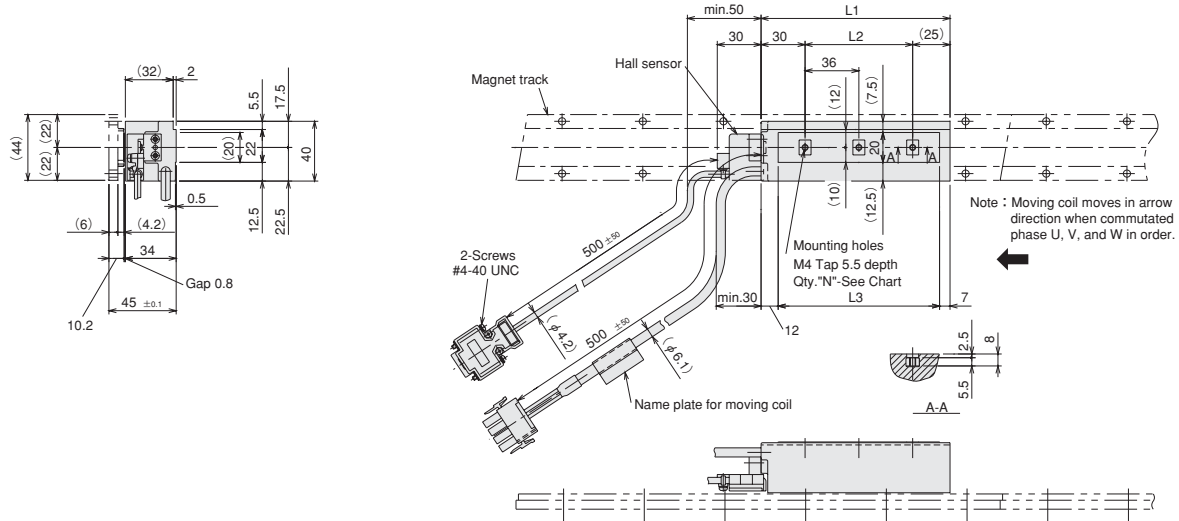

Connector for Hall Sensor

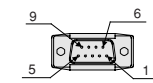

Pin Type
 Connector : 17JE-23090-02 (D8C)
 Daiichi Electronic Industries Co., Ltd.

Mating Types

Socket Type
 Connector : 17JE-13090-02 (D8C)
 Stud : 17L-002C or 17L-002C1

Pin No.	Name
1	+5V (Power supply)
2	Phase U
3	Phase V
4	Phase W
5	0V (Power supply)
6	—
7	—
8	—
9	—

Connector for Motor

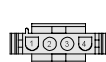

Plug : 350779-1 AMP
 Pin : 350218-3 or 350547-3 (No.1 to 3)
 350654-1 or 350669-1 (No.4)

Mating Type

Cap : 350780-1
 Socket : 350536-3 or 350550-3

Pin No.	Name	Color
1	Phase U	Red
2	Phase V	White
3	Phase W	Black
4	FG	Green

Hall Sensor Output Signal

When the moving coil is moved toward the arrow in the diagram, the relation between the hall sensor's output signals (Su, Sv, Sw) and BEMF of each phase of the motor is as shown in the graph.

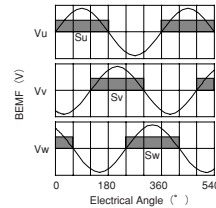

Ⓐ SGLFW-20A090A□

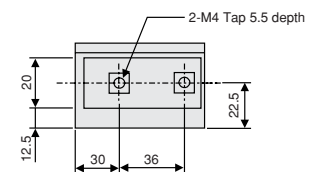

Ⓑ SGLFW-20A120A□

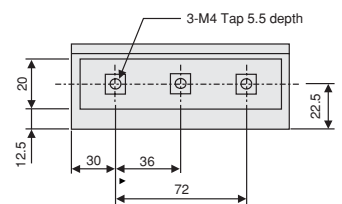

Moving Coil Type SGLFW-□□□□	L1	L2	L3	N	Mass kg
20A090A□	91	36	72	2	0.7
20A120A□	127	72	108	3	0.9

● Magnet Track (SGLFM-20□□□AC)

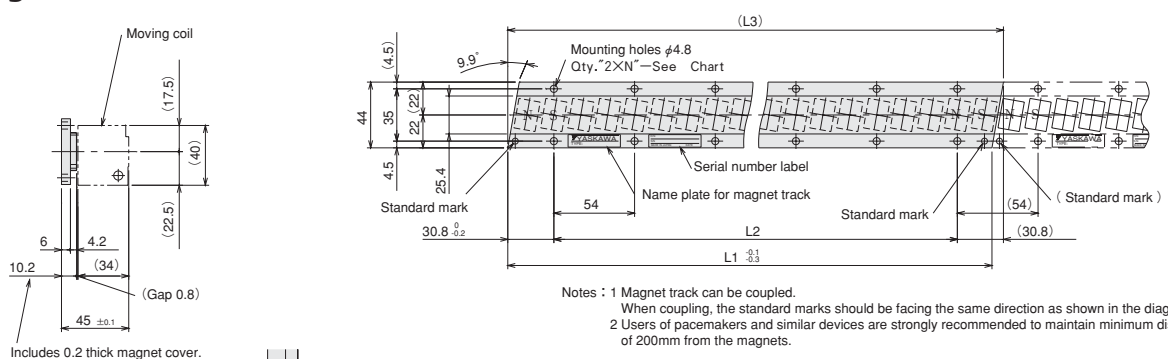

Includes 0.2 thick magnet cover.



Height of screw head is less than 4.2mm.
 Detail drawing of mounting

Notes : 1 Magnet track can be coupled.
 When coupling, the standard marks should be facing the same direction as shown in the diagram.
 2 Users of pacemakers and similar devices are strongly recommended to maintain minimum distance of 200mm from the magnets.

Magnet Track Type SGLFM-□□□□	L1	L2	L3	N	Mass kg
20324AC	324	270	331.6	6	0.9
20540AC	540	486	547.6	10	1.4
20756AC	756	702	763.6	14	2

Linear Σ Servomotor Specifications



Basic Specifications

- Duty Rating : Continuous
- Insulation Resistance : 500VDC 10M Ω or more
- Ambient Temperature : 0 to 40 $^{\circ}$ C
- Motor Type : Sinusoidally commutated permanent magnet brushless linear motor
- Insulation Dielectric Voltage : 1500VAC 1min.
- Cooling Method : Self
- Ambient Humidity : 20 to 80% (non-condensing)
- Allowable Winding Temperature : 130 $^{\circ}$ C (Class B)

Ratings and Specifications

Linear Servomotor Type SGLFW-[]		35A	
		120A[]	230A[]
Continuous Output *	W	200	400
Continuous Force *	N	80	160
Continuous Current *	Arms	1.4	2.8
Peak Force *	N	220	440
Peak Current *	Arms	4.4	8.8
Moving Coil Mass	kg	1.3	2.3
Force Constant	N/Arms	62.4	62.4
BEMF Constant	V/(m/s)	20.8	20.8
Motor Constant	N/ \sqrt{W}	14.4	20.4
Electrical Time Constant	ms	3.6	3.6
Mechanical Time Constant	ms	6.2	5.5
Thermal Resistance (With Heatsink)	K/W	1.57	0.96
Thermal Resistance (Without Heatsink)	K/W	4.10	1.94
Magnetic Attraction Force	N	809	1586

Note : The above values are with aluminum heatsink (254 × 254 × 25mm) mounted to the motor coil. Values marked with asterisks (*) apply when the linear motor is driven from SIGMA-II servodrivers at 20 $^{\circ}$ C, and the coil temperature is at 100 $^{\circ}$ C.

Force vs. Speed Characteristics ([A] : Continuous Duty Zone [B] : Intermittent Duty Zone)

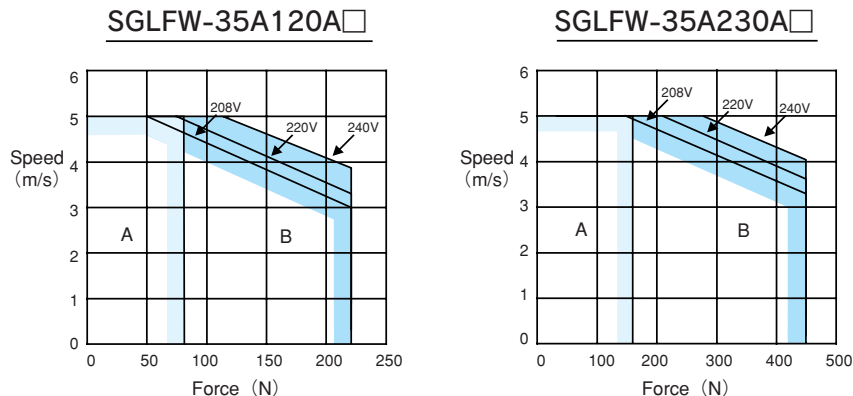

1N=0.2276 lbs.=0.102kgf
 1kg=2.232 lbs.
 1mm=0.03937 in.

Dimensions in mm DXF & DWG drawing files available.

● Moving Coil (SGLFW-35A□□□A□)

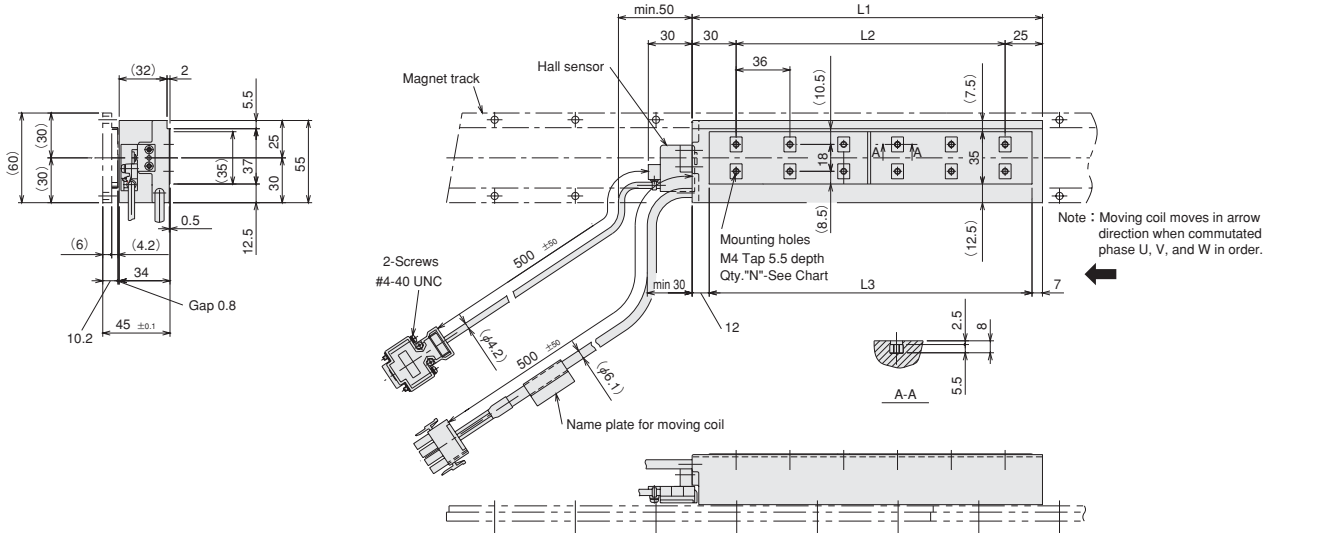

Connector for Hall Sensor

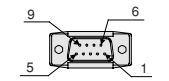

Pin Type
 Connector : 17JE-23090-02 (D8C)
 Daiichi Electronic Industries Co., Ltd.

Mating Types
 Socket Type
 Connector : 17JE-13090-02 (D8C)
 Stud : 17L-002C or 17L-002C1

Pin No.	Name
1	+5V (Power supply)
2	Phase U
3	Phase V
4	Phase W
5	0V (Power supply)
6	—
7	—
8	—
9	—

Connector for Motor

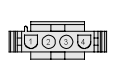

Plug : 350779-1 AMP
 Pin : 350218-3 or 350547-3 (No.1 to 3)
 350654-1
 350669-1 (No.4)

Mating Type
 Cap : 350780-1
 Socket : 350536-3 or 350550-3

Pin No.	Name	Color
1	Phase U	Red
2	Phase V	White
3	Phase W	Black
4	FG	Green

Hall Sensor Output Signal

When the moving coil is moved toward the arrow in the diagram, the relation between the hall sensor's output signals (Su, Sv, Sw) and BEMF of each phase of the motor is as shown in the graph.

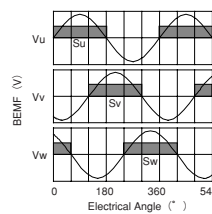

Ⓐ SGLFW-35A120A□

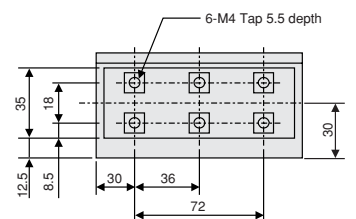

Ⓑ SGLFW-35A230A□

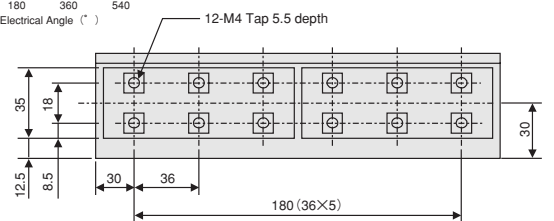

Moving Coil Type SGLFW-□□□□	L1	L2	L3	N	Mass kg
35A120A□	127	72	108	6	1.3
35A230A□	235	180	216	12	2.3

● Magnet Track (SGLFM-35□□□AC)

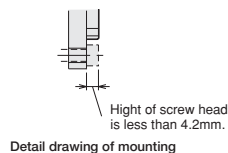
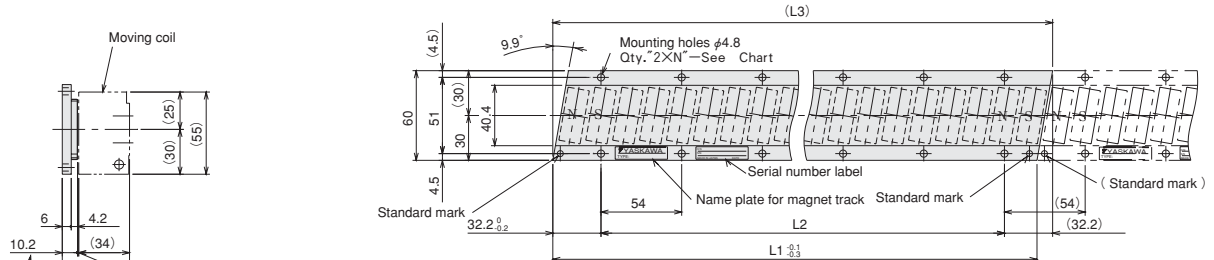

Notes : 1 Magnet track can be coupled.
 When coupling, the standard marks should be facing the same direction as shown in the diagram.
 2 Users of pacemakers and similar devices are strongly recommended to maintain minimum distance of 200mm from the magnets.

Magnet Track Type SGLFM-□□□□	L1	L2	L3	N	Mass kg
35324AC	324	270	334.4	6	1.2
35540AC	540	486	550.4	10	2
35756AC	756	702	766.4	14	2.9

Linear Σ Servomotor Specifications



Basic Specifications

- Duty Rating : Continuous
- Insulation Resistance : 500VDC 10M Ω or more
- Ambient Temperature : 0 to 40 $^{\circ}$ C
- Motor Type : Sinusoidally commutated permanent magnet brushless linear motor
- Insulation Dielectric Voltage : 1500VAC 1min.
- Cooling Method : Self
- Ambient Humidity : 20 to 80% (non-condensing)
- Allowable Winding Temperature : 130 $^{\circ}$ C (Class B)

Ratings and Specifications

Linear Servomotor Type SGLFW-[]		50A	
		200A []	380A []
Continuous Output *	W	500	1000
Continuous Force *	N	200	400
Continuous Current *	Arms	3.2	6.3
Peak Force *	N	600	1200
Peak Current *	Arms	10.9	21.8
Moving Coil Mass	kg	3.7	6.9
Force Constant	N/Arms	67.9	67.9
BEMF Constant	V/(m/s)	22.6	22.6
Motor Constant	N/ \sqrt{W}	29.3	41.1
Electrical Time Constant	ms	9.6	9.4
Mechanical Time Constant	ms	4.1	4.1
Thermal Resistance (With Heatsink)	K/W	1.12	0.46
Thermal Resistance (Without Heatsink)	K/W	2.13	1.06
Magnetic Attraction Force	N	2095	4144

Note : The above values are with aluminum heatsink (200A : 254 \times 254 \times 25mm, 380A : 400 \times 500 \times 40mm) mounted to the motor coil. Values marked with asterisks (*) apply when the linear motor is driven from SIGMA-II servodrivers at 20 $^{\circ}$ C, and the coil temperature is at 100 $^{\circ}$ C.

Force vs. Speed Characteristics ([A] : Continuous Duty Zone [B] : Intermittent Duty Zone)

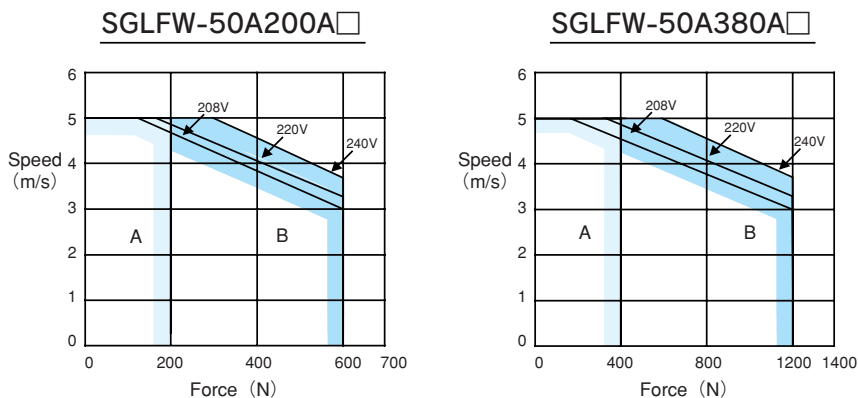

1N=0.2276 lbs.=0.102kgf
1kg=2.232 lbs.
1mm=0.03937 in.

Dimensions in mm DXF & DWG drawing files available.

● Moving Coil (SGLFW-50A□□□A□)

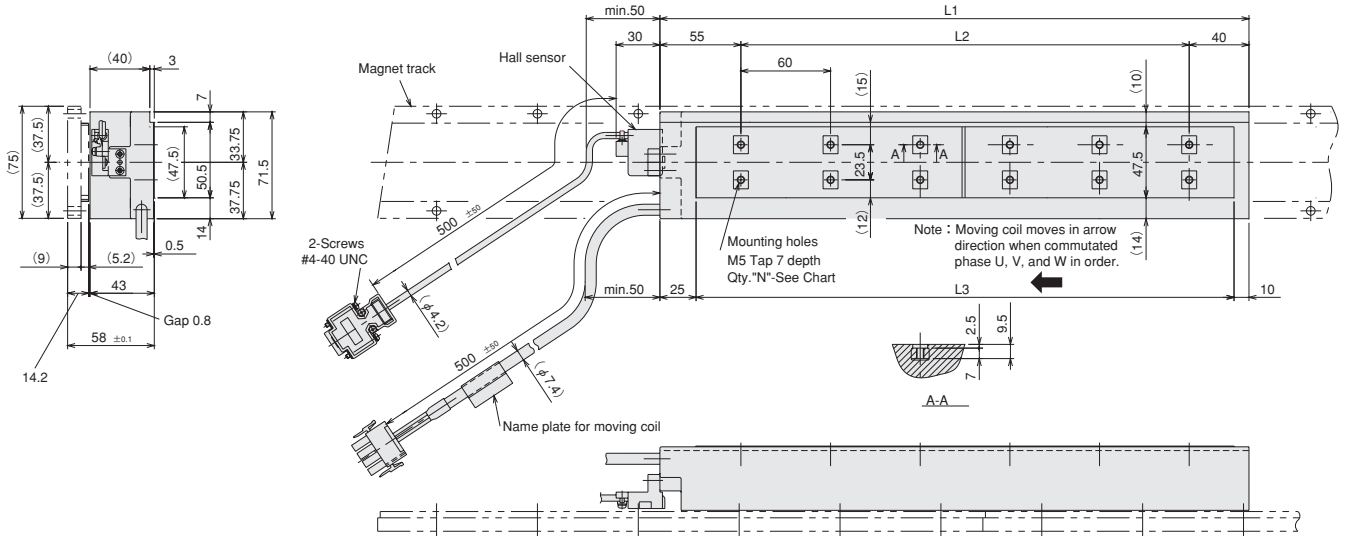

Connector for Hall Sensor

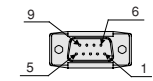

Pin Type
Connector : 17JE-23090-02 (D8C)
Daiichi Electronic Industries Co., Ltd.

Mating Types

Socket Type
Connector : 17JE-13090-02 (D8C)
Stud : 17L-002C or 17L-002C1

Pin No.	Name
1	+5V (Power supply)
2	Phase U
3	Phase V
4	Phase W
5	0V (Power supply)
6	—
7	—
8	—
9	—

Connector for Motor

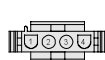

Plug : 350779-1 AMP
Pin : 350218-3 or 350547-3 (No.1 to 3)
350654-1
350669-1 (No.4)

Mating Type

Cap : 350780-1
Socket : 350536-3 or 350550-3

Pin No.	Name	Color
1	Phase U	Red
2	Phase V	White
3	Phase W	Black
4	FG	Green

Hall Sensor Output Signal

When the moving coil is moved toward the arrow in the diagram, the relation between the hall sensor's output signals (Su, Sv, Sw) and BEMF of each phase of the motor is as shown in the graph.

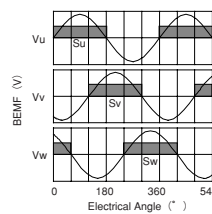

① SGLFW-50A200A□

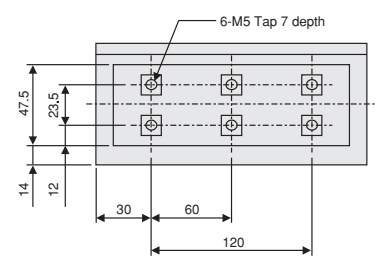

② SGLFW-50A380A□

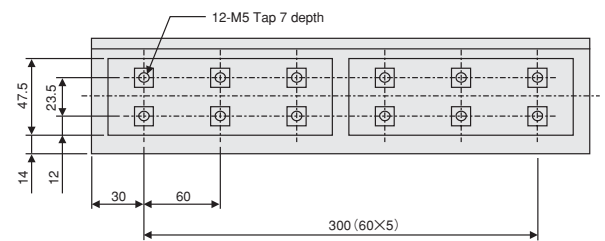

Moving Coil Type	L1	L2	L3	N	Mass kg
SGLFW-50A200A□	215	120	180	6	3.7
SGLFW-50A380A□	395	300	360	12	6.9

● Magnet Track (SGLFM-50□□□AC)

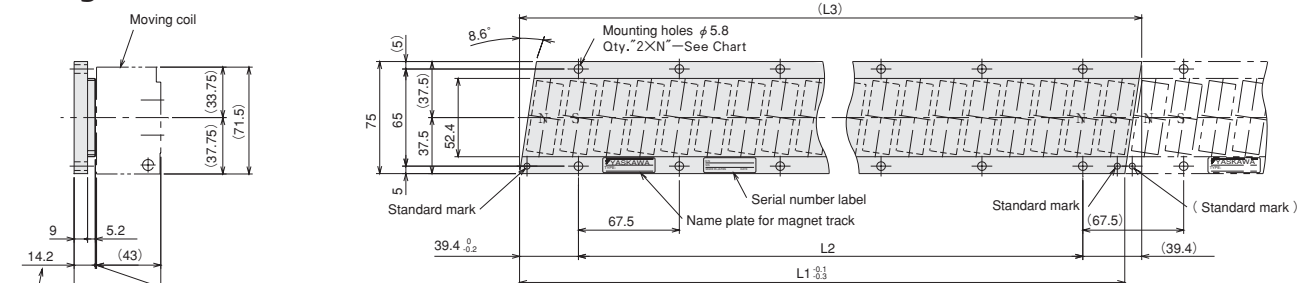

Notes : 1 Magnet track can be coupled.

When coupling, the standard marks should be facing the same direction as shown in the diagram.

2 Users of pacemakers and similar devices are strongly recommended to maintain minimum distance of 200mm from the magnets.

Magnet Track Type	L1	L2	L3	N	Mass kg
SGLFM-50405AC	405	337.5	416.3	6	2.8
SGLFM-50675AC	675	607.5	686.3	10	4.6
SGLFM-50945AC	945	877.5	956.3	14	6.5

Linear Σ Servomotor Specifications



Basic Specifications

- Duty Rating : Continuous
- Insulation Resistance : 500VDC 10M Ω or more
- Ambient Temperature : 0 to 40 $^{\circ}$ C
- Motor Type : Sinusoidally commutated permanent magnet brushless linear motor
- Insulation Dielectric Voltage : 1500VAC 1min.
- Cooling Method : Self
- Ambient Humidity : 20 to 80% (non-condensing)
- Allowable Winding Temperature : 130 $^{\circ}$ C (Class B)

Ratings and Specifications

Linear Servomotor Type SGLFW-[] []		1ZA	
		200A []	380A []
Continuous Output *	W	1000	2000
Continuous Force *	N	400	800
Continuous Current *	Arms	5.7	11.4
Peak Force *	N	1200	2400
Peak Current *	Arms	19.7	39.3
Moving Coil Mass	kg	6.4	11.5
Force Constant	N/Arms	75.3	75.3
BEMF Constant	V/(m/s)	25.1	25.1
Motor Constant	N/ \sqrt{W}	44.6	62.4
Electrical Time Constant	ms	10.4	9.7
Mechanical Time Constant	ms	3.2	3.0
Thermal Resistance (With Heatsink)	K/W	0.82	0.39
Thermal Resistance (Without Heatsink)	K/W	1.34	0.79
Magnetic Attraction Force	N	4190	8289

Note : The above values are with aluminum heatsink (200A : 254 \times 254 \times 25mm, 380A : 400 \times 500 \times 40mm) mounted to the motor coil. Values marked with asterisks (*) apply when the linear motor is driven from SIGMA-II servodrivers at 20 $^{\circ}$ C, and the coil temperature is at 100 $^{\circ}$ C.

Force vs. Speed Characteristics ([] : Continuous Duty Zone [] : Intermittent Duty Zone)

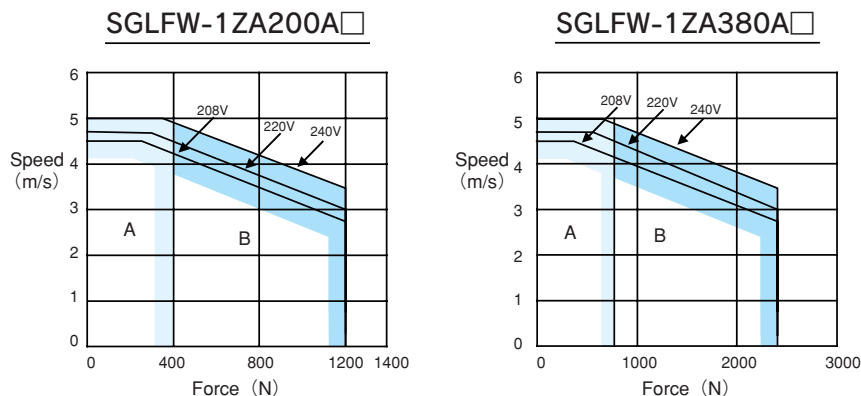

1N=0.2276 lbs.=0.102kgf
 1kg=2.232 lbs.
 1mm=0.03937 in.

Dimensions in mm

DXF & DWG drawing files available.

● Moving Coil (SGLFW-1ZA□□□A□)

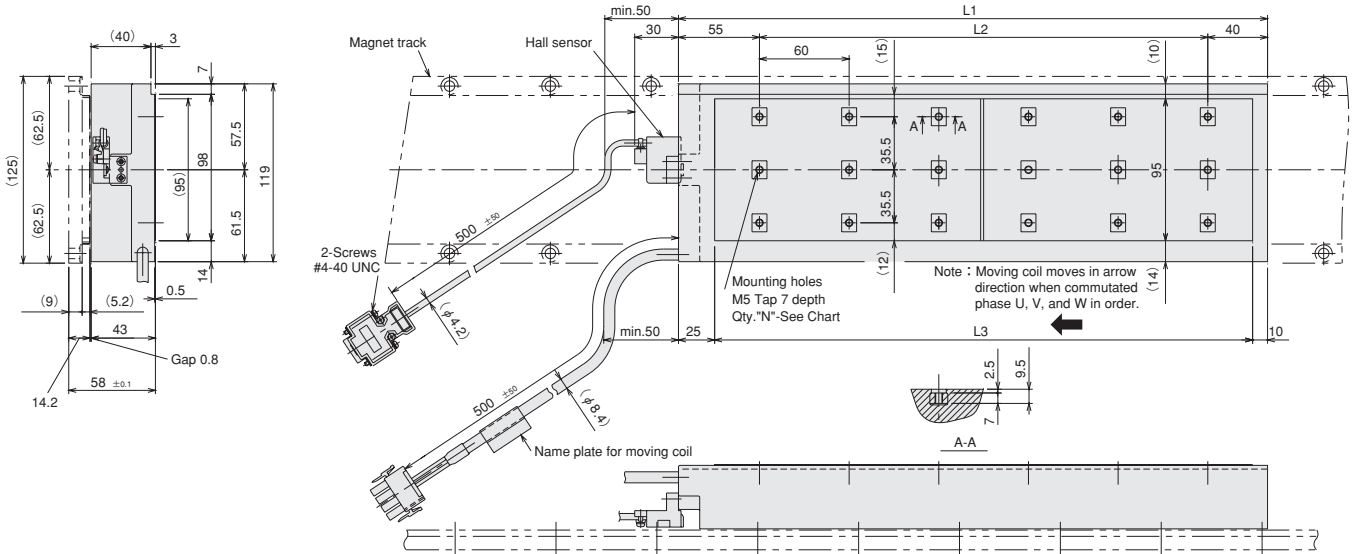

Connector for Hall Sensor

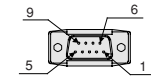

Pin Type
 Connector: 17JE-23090-02 (D8C)
 Daiichi Electronic Industries Co., Ltd.

Mating Types

Socket Type
 Connector: 17JE-13090-02 (D8C)
 Stud: 17L-002C or 17L-002C1

Pin No.	Name
1	+5V (Power supply)
2	Phase U
3	Phase V
4	Phase W
5	0V (Power supply)
6	-
7	-
8	-
9	-

Connector for Motor

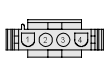

Plug: 350779-1 AMP
 Pin: 350218-3 or 350547-3 (No.1 to 3)
 350654-1
 350669-1 (No.4)

Mating Type

Cap: 350780-1
 Socket: 350536-3 or 350550-3

Pin No.	Name	Color
1	Phase U	Red
2	Phase V	White
3	Phase W	Black
4	FG	Green

Hall Sensor Output Signal

When the moving coil is moved toward the arrow in the diagram, the relation between the hall sensor's output signals (Su, Sv, Sw) and BEMF of each phase of the motor is as shown in the graph.

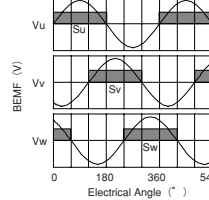

① SGLFW-1ZA200A□

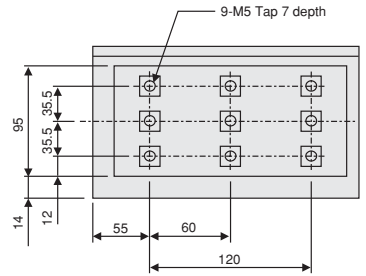

② SGLFW-1ZA380A□

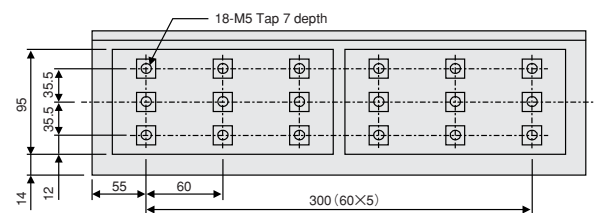

Moving Coil Type SGLFW-□□□□	L1	L2	L3	N	Mass kg
1ZA200A□	215	120	180	9	6.4
1ZA380A□	395	300	360	18	11.5

● Magnet Track (SGLFM-1Z□□□AC)

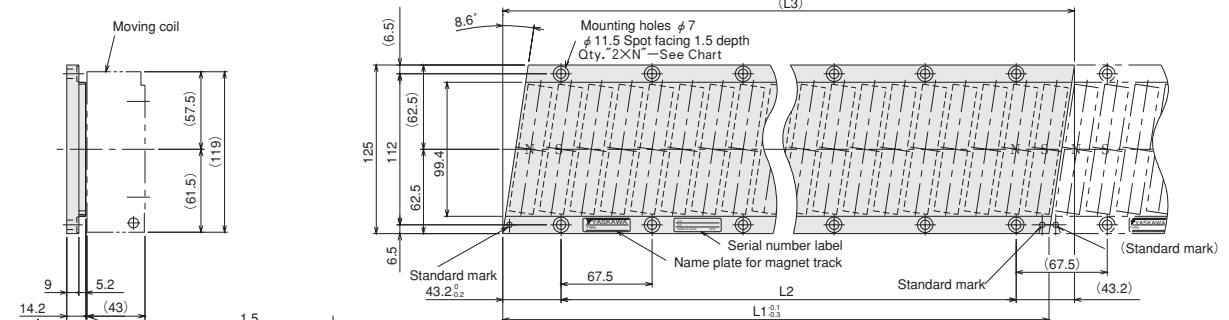

Notes: 1 Magnet track can be coupled.

When coupling, the standard marks should be facing the same direction as shown in the diagram.

2 Users of pacemakers and similar devices are strongly recommended to maintain minimum distance of 200mm from the magnets.

Magnet Track Type SGLFM-□□□□	L1	L2	L3	N	Mass kg
1Z405AC	405	337.5	423.9	6	7.3
1Z675AC	675	607.5	693.9	10	12
1Z945AC	945	877.5	963.9	14	17

Linear Σ Servomotor Specifications



Iron-core TW SGLTW-20A

Basic Specifications

- Duty Rating : Continuous
- Insulation Resistance : 500VDC 10M Ω or more
- Ambient Temperature : 0 to 40 $^{\circ}$ C
- Motor Type : Sinusoidally commutated permanent magnet brushless linear motor
- Insulation Dielectric Voltage : 1500VAC 1min.
- Cooling Method : Self
- Ambient Humidity : 20 to 80% (non-condensing)
- Allowable Winding Temperature : 130 $^{\circ}$ C (Class B)

Ratings and Specifications

Linear Servomotor Type	SGLTW-[]	20A		
		170A[]	320A[]	460A[]
Continuous Output *	W	325	625	950
Continuous Force *	N	130	250	380
Continuous Current *	Arms	2.3	4.4	6.7
Peak Force *	N	380	760	1140
Peak Current *	Arms	7.7	15.4	23.2
Moving Coil Mass	kg	2.6	4.6	6.7
Force Constant	N/Arms	61.0	61.0	61.0
BEMF Constant	V/(m/s)	20.3	20.3	20.3
Motor Constant	N/ \sqrt{W}	18.7	26.5	32.3
Electrical Time Constant	ms	5.9	5.9	5.9
Mechanical Time Constant	ms	7.5	6.5	6.4
Thermal Resistance (With Heatsink)	K/W	1.01	0.49	0.38
Thermal Resistance (Without Heatsink)	K/W	1.82	1.11	0.74
Magnetic Attraction Force	N	0	0	0

Note : The above values are with aluminum heatsink (170A : 254 \times 254 \times 25mm, 320A/460A : 400 \times 500 \times 40mm) mounted to the motor coil. Values marked with asterisks (*) apply when the linear motor is driven from SIGMA-II servodrivers at 20 $^{\circ}$ C, and the coil temperature is at 100 $^{\circ}$ C.

Force vs. Speed Characteristics ([A] : Continuous Duty Zone [B] : Intermittent Duty Zone)

SGLTW-20A170A[]

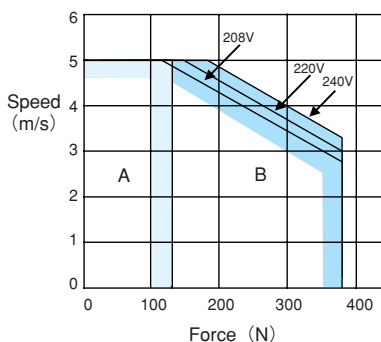

SGLTW-20A320A[]

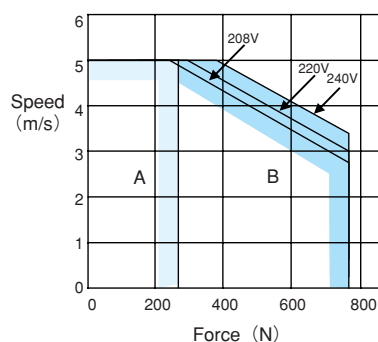

SGLTW-20A460A[]

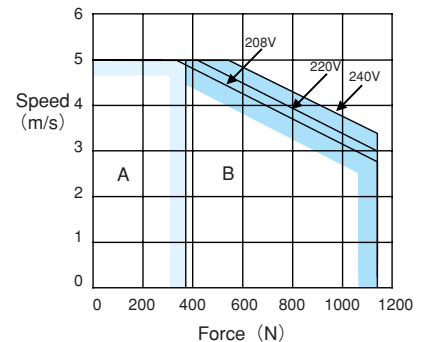

1N=0.2276 lbs.=0.102kgf
 1kg=2.232 lbs.
 1mm=0.03937 in.

Dimensions in mm DXF & DWG drawing files available.

● Moving Coil (SGLTW-20A□□□A□)

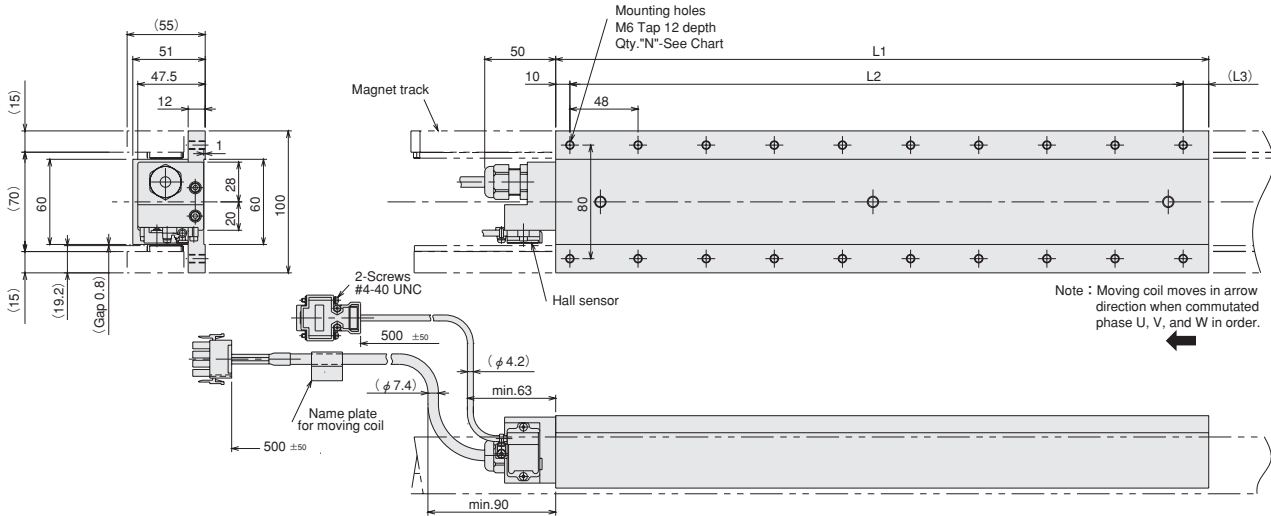

Connector for Hall Sensor

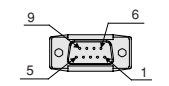

Pin Type
 Connector : 17JE-23090-02 (D8C)
 Daiichi Electronic Industries Co., Ltd.

Mating Types

Socket Type
 Connector : 17JE-13090-02 (D8C)
 Stud : 17L-002C or 17L-002C1

Pin No.	Name
1	+5V (Power Supply)
2	Phase U
3	Phase V
4	Phase W
5	0V (Power Supply)
6	—
7	—
8	—
9	—

Connector for Motor

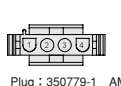

Plug : 350779-1 AMP
 Pin : 350218-3 or 350547-3 (No.1 to 3)
 350654-1
 350669-1 (No.4)

Mating Type

Cap : 350780-1
 Socket : 350536-3 or 350550-3

Pin No.	Name	Color
1	Phase U	Red
2	Phase V	White
3	Phase W	Black
4	FG	Green

Hall Sensor Output Signal

When the moving coil is moved toward the arrow in the diagram, the relation between the hall sensor's output signals (Su, Sv, Sw) and BEMF of each phase of the motor is as shown in the graph.

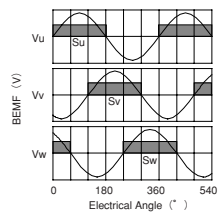

Moving Coil Type	L1	L2	L3	N	Mass kg
SGLTW-20A170A□	170	144	16	8	2.6
20A320A□	315	288	17	14	4.8
20A460A□	460	432	18	20	7

● Magnet Track (SGLTM-20□□□AY)

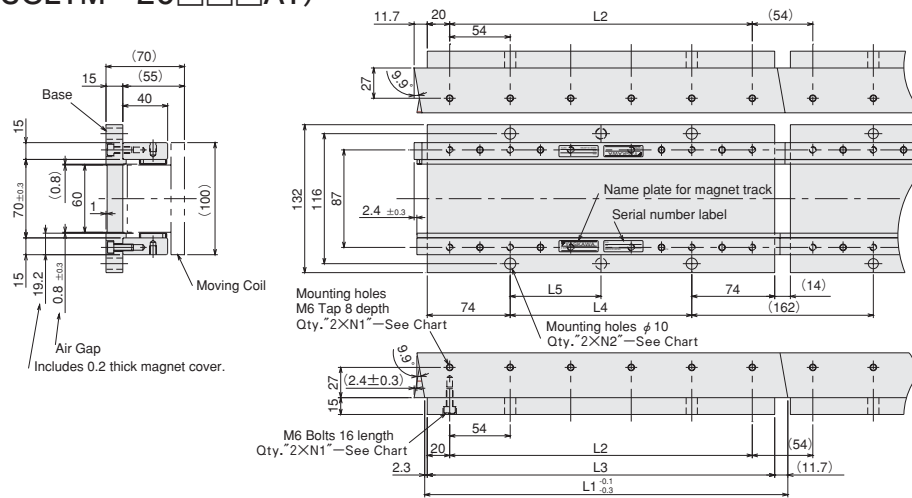

Magnet Track Type	L1	L2	L3	L4	L5	N1	N2	Mass kg
SGLTM-20324AY	324	270	310	162	162	6	2	5.1
20540AY	540	486	526	378	189	10	3	8.5
20756AY	756	702	742	594	198	14	4	12

Note : Users of pacemakers and similar devices are strongly recommended to maintain minimum distance of 200mm from the magnets.

Linear Σ Servomotor Specifications

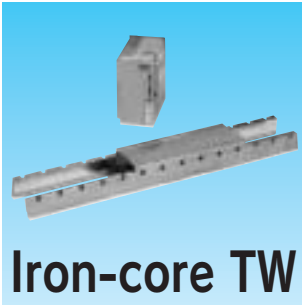

Iron-core TW SGLTW-35A

Basic Specifications

- Duty Rating : Continuous
- Insulation Resistance : 500VDC 10M Ω or more
- Ambient Temperature : 0 to 40 $^{\circ}$ C
- Motor Type : Sinusoidally commutated permanent magnet brushless linear motor
- Insulation Dielectric Voltage : 1500VAC 1min.
- Cooling Method : Self
- Ambient Humidity : 20 to 80% (non-condensing)
- Allowable Winding Temperature : 130 $^{\circ}$ C (Class B)

Ratings and Specifications

Linear Servomotor Type	SGLTW-[]	35A		
		170A[]	320A[]	460A[]
Continuous Output *	W	550	1100	1675
Continuous Force *	N	220	440	670
Continuous Current *	Arms	3.5	7	10.7
Peak Force *	N	660	1320	2000
Peak Current *	Arms	12.1	24.2	36.7
Moving Coil Mass	kg	3.7	6.8	10.0
Force Constant	N/Arms	67.5	67.5	67.5
BEMF Constant	V/(m/s)	22.5	22.5	22.5
Motor Constant	N/ \sqrt{W}	26.7	37.5	46.4
Electrical Time Constant	ms	6.9	6.8	7.0
Mechanical Time Constant	ms	5.2	4.8	4.6
Thermal Resistance (With Heatsink)	K/W	0.76	0.44	0.32
Thermal Resistance (Without Heatsink)	K/W	1.26	0.95	0.61
Magnetic Attraction Force	N	0	0	0

Note :The above values are with aluminum heatsink (170A : 254 × 254 × 25mm, 320A/460A : 400 × 500 × 40mm) mounted to the motor coil. Values marked with asterisks (*) apply when the linear motor is driven from SIGMA-II servodrivers at 20 $^{\circ}$ C, and the coil temperature is at 100 $^{\circ}$ C.

Force vs. Speed Characteristics ([A] : Continuous Duty Zone [B] : Intermittent Duty Zone)

SGLTW-35A170A[]

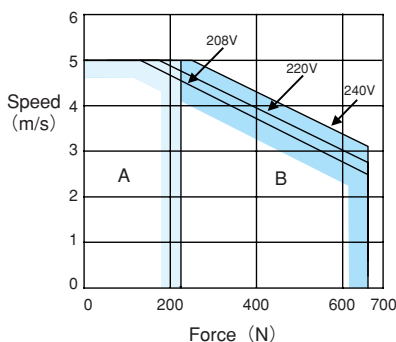

SGLTW-35A320A[]

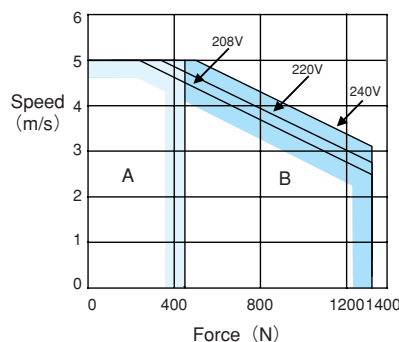

SGLTW-35A460A[]

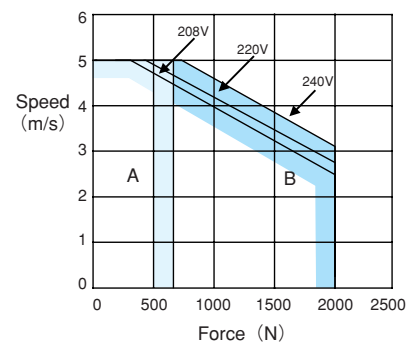

1N=0.2276 lbs.=0.102kgf
 1kg=2.232 lbs.
 1mm=0.03937 in.

Dimensions in mm DXF & DWG drawing files available.

● Moving Coil (SGLTW-35A□□□A□)

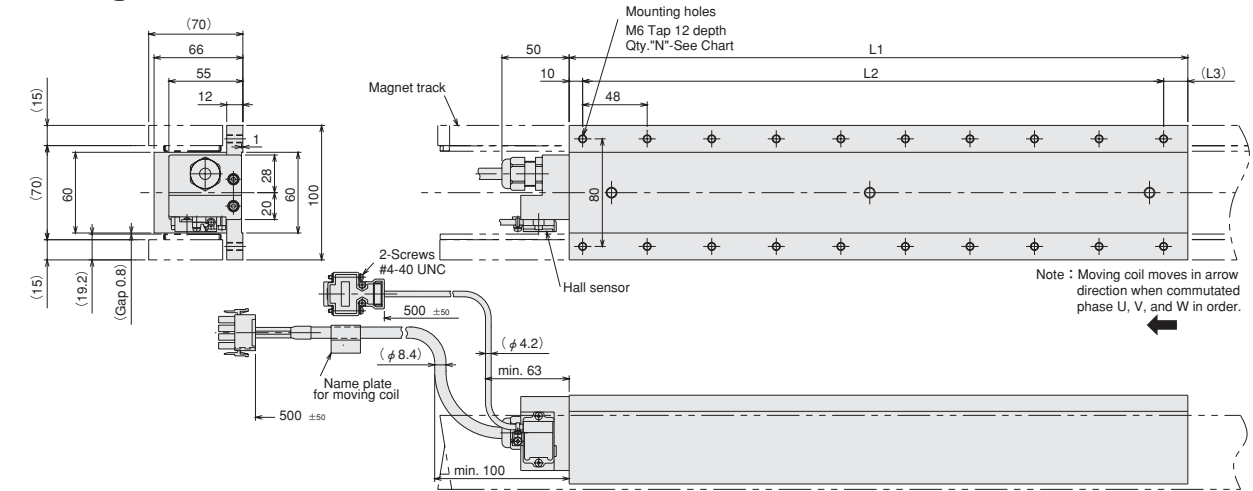

Note : Moving coil moves in arrow direction when commutated phase U, V, and W in order.

Connector for Hall Sensor

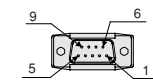

Pin Type
 Connector : 17JE-23090-02 (D8C)
 Daiichi Electronic Industries Co., Ltd.

Mating Types

Socket Type
 Connector : 17JE-13090-02 (D8C)
 Stud : 17L-002C or 17L-002C1

Pin No.	Name
1	+5V (Power Supply)
2	Phase U
3	Phase V
4	Phase W
5	0V (Power Supply)
6	—
7	—
8	—
9	—

Connector for Motor

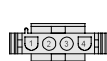

Plug : 350779-1 AMP
 Pin : 350218-3 or 350547-3 (No.1 to 3)
 350654-1
 350669-1 (No.4)

Mating Type

Cap : 350780-1
 Socket : 350536-3 or 350550-3

Pin No.	Name	Color
1	Phase U	Red
2	Phase V	White
3	Phase W	Black
4	FG	Green

Hall Sensor Output Signal

When the moving coil is moved toward the arrow in the diagram, the relation between the hall sensor's output signals (Su, Sv, Sw) and BEMF of each phase of the motor is as shown in the graph.

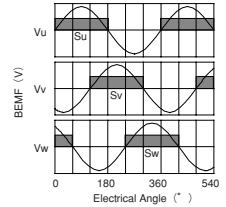

Moving Coil Type SGLTW-□□□□	L1	L2	L3	N	Mass kg
35A170A□	170	144	16	8	3.7
35A320A□	315	288	17	14	6.8
35A460A□	460	432	18	20	10

● Magnet Track (SGLTM-20□□□AY)

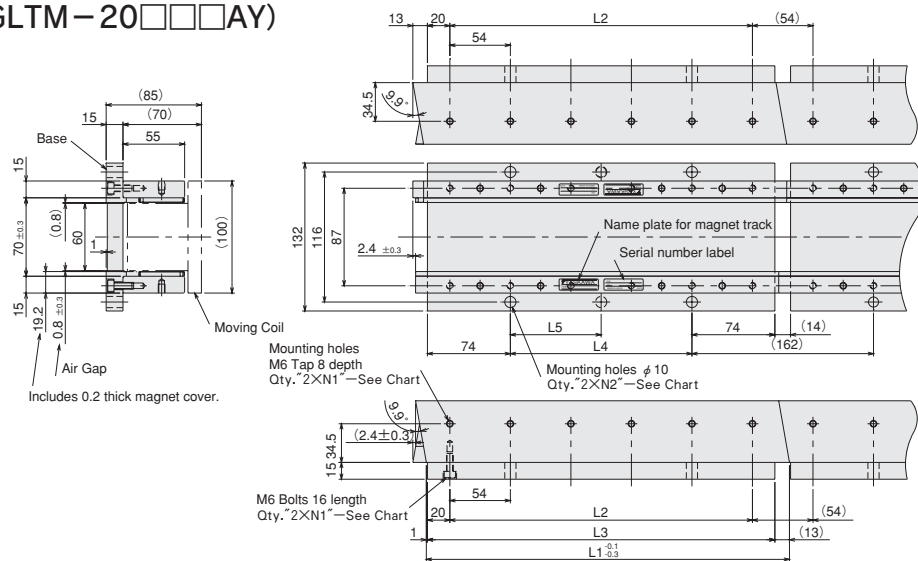

Mounting holes
 M6 Tap 8 depth
 Qty."2XN1"—See Chart

Mounting holes ϕ 10
 Qty."2XN2"—See Chart

M6 Bolts 16 length
 Qty."2XN1"—See Chart

Magnet Track Type SGLTM-□□□□	L1	L2	L3	L4	L5	N1	N2	Mass kg
35324AY	324	270	310	162	162	6	2	6.4
35540AY	540	486	526	378	189	10	3	11
35756AY	756	702	742	594	198	14	4	15

Note : Users of pacemakers and similar devices are strongly recommended to maintain minimum distance of 200mm from the magnets.

Linear Σ Servomotor Specifications



Iron-core TW SGLTW-40A

Basic Specifications

- Duty Rating : Continuous
- Insulation Resistance : 500VDC 10M Ω or more
- Ambient Temperature : 0 to 40 $^{\circ}$ C
- Motor Type : Sinusoidally commutated permanent magnet brushless linear motor
- Insulation Dielectric Voltage : 1500VAC 1min.
- Cooling Method : Self
- Ambient Humidity : 20 to 80% (non-condensing)
- Allowable Winding Temperature : 130 $^{\circ}$ C (Class B)

Ratings and Specifications

Linear Servomotor Type	SGLTW-[]	40A	
		400A[]	600A[]
Continuous Output *	W	1675	2500
Continuous Force *	N	670	1000
Continuous Current *	Arms	10.8	16.1
Peak Force *	N	2000	3000
Peak Current *	Arms	37	55.5
Moving Coil Mass	kg	20.0	30.0
Force Constant	N/Arms	66.9	66.9
BEMF Constant	V/(m/s)	22.3	22.3
Motor Constant	N/ \sqrt{W}	64.1	76.6
Electrical Time Constant	ms	17.8	16.5
Mechanical Time Constant	ms	4.9	5.1
Thermal Resistance (With Heatsink)	K/W	0.34	0.23
Thermal Resistance (Without Heatsink)	K/W	0.60	0.47
Magnetic Attraction Force	N	0	0

Note : The above values are with aluminum heatsink (609 \times 762 \times 50mm) mounted to the motor coil. Values marked with asterisks (*) apply when the linear motor is driven from SIGMA-II servodrivers at 20 $^{\circ}$ C, and the coil temperature is at 100 $^{\circ}$ C.

Force vs. Speed Characteristics ([A] : Continuous Duty Zone [B] : Intermittent Duty Zone)

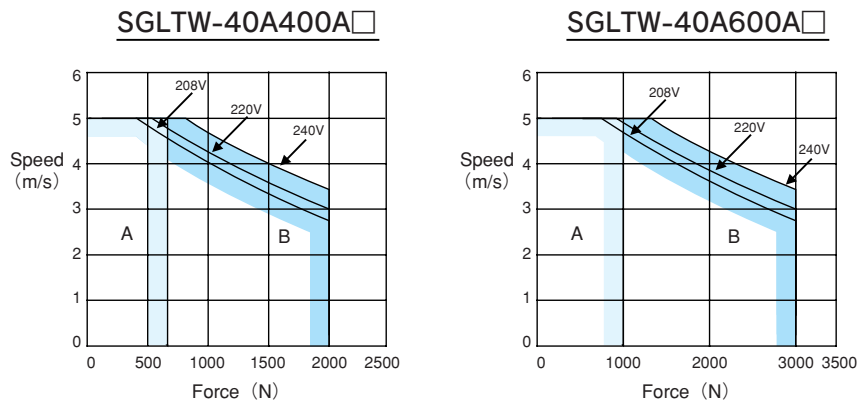

1N=0.2276 lbs.=0.102kgf
 1kg=2.232 lbs.
 1mm=0.03937 in.

Dimensions in mm DXF & DWG drawing files available.

● Moving Coil (SGLTW-40□□□A□)

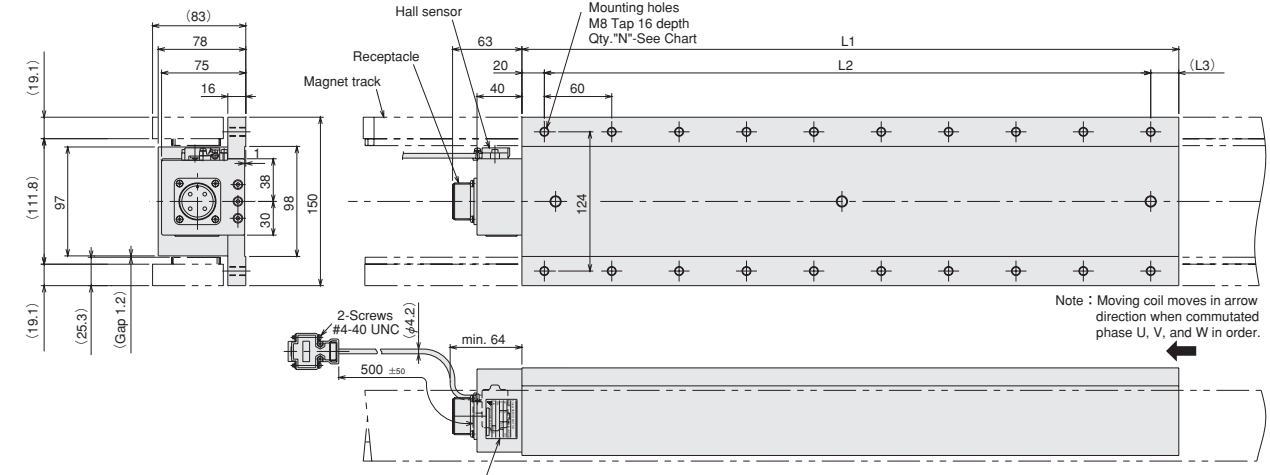

Connector for Hall Sensor

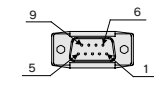

Pin Type
 Connector : 17JE-23090-02 (D8C)
 Daiichi Electronic Industries Co., Ltd.

Mating Types
 Socket Type
 Connector : 17JE-13090-02 (D8C)
 Stud : 17L-002C or 17L-002C1

Pin No.	Name
1	+5V (Power Supply)
2	Phase U
3	Phase V
4	Phase W
5	0V (Power Supply)
6	—
7	—
8	—
9	—

Connector for moving coil



Receptacle : MS3102A-22-22P
 Made by Daiichi Electronic Industries Co., Ltd.

Mating Type
 L-type Plug : MS3108B22-22S
 Straight Plug : MS3106B22-22S
 Cable Clamp : MS3057-12A

Hall Sensor Output Signal

When the moving coil is moved toward the arrow in the diagram, the relation between the hall sensor's output signals (Su, Sv, Sw) and BEMF of each phase of the motor is as shown in the graph.

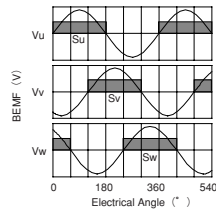

Moving Coil Type SGLTW-□□□□	L1	L2	L3	N	Mass kg
40A400A	395	360	15	14	20
40A600A	585	540	25	20	30

● Magnet Track (SGLTM-40□□□AY)

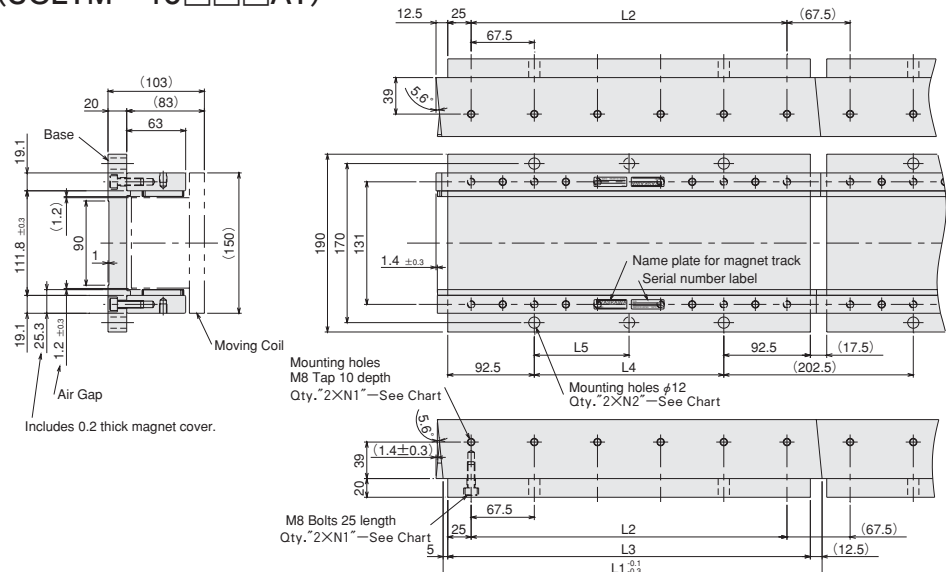

Note: Users of pacemakers and similar devices are strongly recommended to maintain minimum distance of 200mm from the magnets.

Magnet Track Type SGLTM-□□□□	L1	L2	L3	L4	L5	N1	N2	Mass kg
40405AY	405	337.5	387.5	202.5	202.5	6	2	13
40675AY	675	607.5	657.5	472.5	236.25	10	3	21
40945AY	945	877.5	927.5	742.5	247.5	14	4	30

Linear Σ Servomotor Specifications

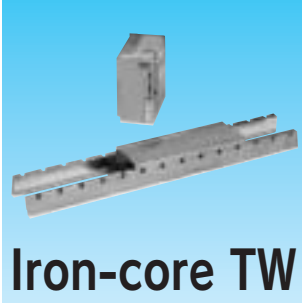

Iron-core TW SGLTW-80A

Basic Specifications

- Duty Rating : Continuous
- Insulation Resistance : 500VDC 10M Ω or more
- Ambient Temperature : 0 to 40 $^{\circ}$ C
- Motor Type : Sinusoidally commutated permanent magnet brushless linear motor
- Insulation Dielectric Voltage : 1500VAC 1min.
- Cooling Method : Self
- Ambient Humidity : 20 to 80% (non-condensing)
- Allowable Winding Temperature : 130 $^{\circ}$ C (Class B)

Ratings and Specifications

Linear Servomotor Type	SGLTW-[] []	80A	
		400A [] []	600A [] []
Continuous Output *	W	2600	4000
Continuous Force *	N	1300	2000
Continuous Current *	Arms	19.3	29.7
Peak Force *	N	4000	6000
Peak Current *	Arms	67.8	101.8
Moving Coil Mass	kg	30.0	43.0
Force Constant	N/Arms	72.6	72.6
BEMF Constant	V/(m/s)	24.2	24.2
Motor Constant	N/ \sqrt{W}	89.7	105.4
Electrical Time Constant	ms	19.3	16.6
Mechanical Time Constant	ms	3.7	3.9
Thermal Resistance (With Heatsink)	K/W	0.28	0.19
Thermal Resistance (Without Heatsink)	K/W	0.55	0.36
Magnetic Attraction Force	N	0	0

Note : The above values are with aluminum heatsink (609 \times 762 \times 50mm) mounted to the motor coil. Values marked with asterisks (*) apply when the linear motor is driven from SIGMA-II servodrivers at 20 $^{\circ}$ C, and the coil temperature is at 100 $^{\circ}$ C.

Force vs. Speed Characteristics ([] A : Continuous Duty Zone [] B : Intermittent Duty Zone)

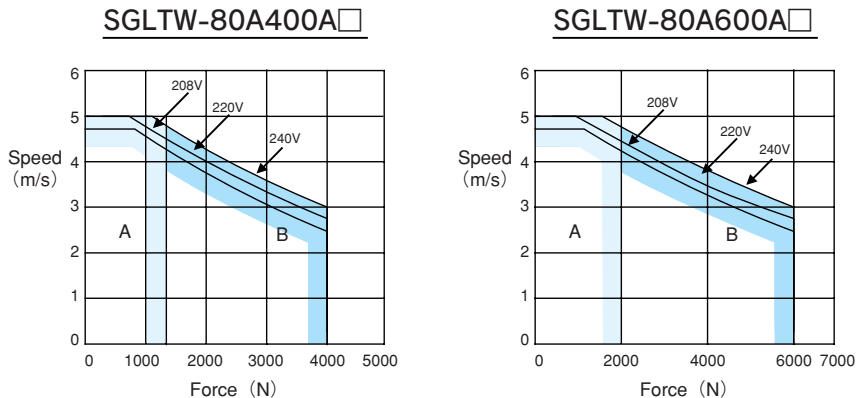

1N=0.2276 lbs.=0.102kgf
 1kg=2.232 lbs.
 1mm=0.03937 in.

Dimensions in mm DXF & DWG drawing files available.

● Moving Coil (SGLTW-80A□□□A□)

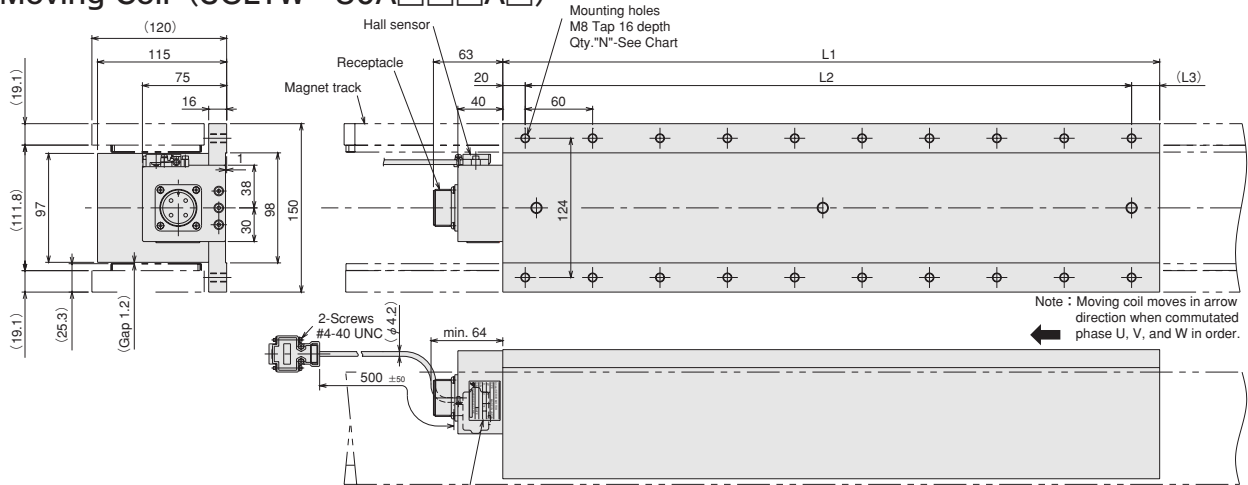

Connector for Hall Sensor

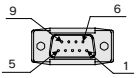

Pin Type
 Connector : 17JE-23090-02 (D8C)
 Daiichi Electronic Industries Co., Ltd.

Mating Types

Socket Type
 Connector : 17JE-13090-02 (D8C)
 Stud : 17L-002C or 17L-002C1

Pin No.	Name
1	+5V (Power Supply)
2	Phase U
3	Phase V
4	Phase W
5	0V (Power Supply)
6	—
7	—
8	—
9	—

Name plate for moving coil

Connector for Motor



Receptacle : MS3102A-22-22P
 Made by Daiichi Electronic Industries Co., Ltd.

Mating Type

L-type Plug : MS3108B22-22S
 Straight Plug : MS3106B22-22S
 Cable Clamp : MS3057-12A

Hall Sensor Output Signal

When the moving coil is moved toward the arrow in the diagram, the relation between the hall sensor's output signals (Su, Sv, Sw) and BEMF of each phase of the motor is as shown in the graph.

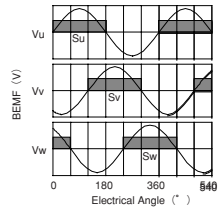

Moving Coil Type SGLTW-□□□□	L1	L2	L3	N	Mass kg
80A400A□	395	360	15	14	30
80A600A□	585	540	25	20	43

● Magnet Track (SGLTM-80□□□AY)

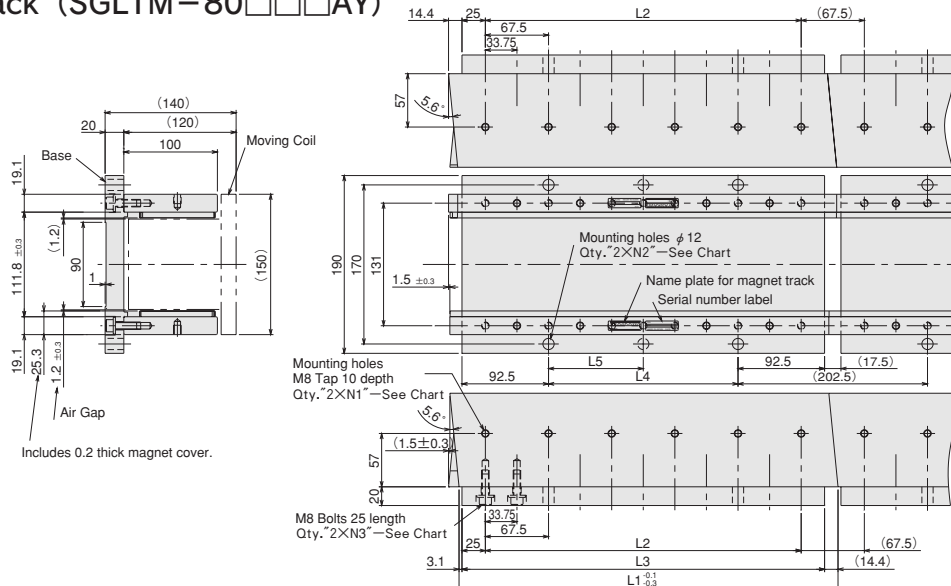

Includes 0.2 thick magnet cover.

Magnet Track Type SGLTM-□□□□	L1	L2	L3	L4	L5	N1	N2	N3	Mass kg
80405AY	405	337.5	387.5	202.5	202.5	6	2	11	18
80675AY	675	607.5	657.5	472.5	236.25	10	3	19	31
80945AY	945	877.5	927.5	742.5	247.5	14	4	27	43

Note : Users of pacemakers and similar devices are strongly recommended to maintain minimum distance of 200mm from the magnets.

Servodriver(SERVOPACK) Specifications



SGDH

Ratings and Specifications

Basic Specifications	Conditions	Usage/storage Temperature	0 to +55°C/−20 to +85°C	
		Usage/storage Humidity	90% RH or less (non-condensing)	
		Altitude	1000m or less above sea level	
		Vibration/Shock Resistance	4.9m/s ² /19.6m/s ²	
Speed/Force Control Mode	Performance	Speed Control Range	1 : 5000 (The lower limit of speed is under rated load and no stopping conditions.)	
		Speed Variance	Load Variance	During 0 to 100% load : ±0.01% or less (at rated speed)
			Voltage Variance	Rated voltage ±10% : 0% (at rated speed)
			Temperature Variance	25 ±25°C : ±0.1% or less (at rated speed)
	Frequency Characteristics	400Hz (at J _L = J _M)		
	Torque Control Accuracy(Repeatability)	±2%		
	Soft Start Time Setting	0 to 10s (Acceleration, deceleration each.)		
	Input Signal	Speed Reference Input	Reference Voltage	±6VDC at rated speed : set at delivery Variable setting range : ±2 to ±10VDC at rated speed/max. input voltage : ±12V
			Input Impedance	Approx. 14kΩ
			Circuit Time Constant	—
Force Reference Input		Reference Voltage	±3VDC at rated thrust : set at delivery Variable setting range : ±1 to ±10VDC at rated torque reference / max. input voltage : ±12V	
		Input Impedance	Approx. 14kΩ	
		Circuit Time Constant	Approx. 47 μs	
Position Control Mode	Performance	Bias Setting	0 to 450 r/min. (setting resolution : 1 r/min)	
		Feed Forward Gain Compensation	0 to 100% (setting resolution : 1%)	
		Position Completed Width Setting	0 to 250 reference units (setting resolution : 1 reference unit)	
	Input Signal	Reference Pulse	Input Pulse Type	Sign + pulse train, 90° phase displacement 2-phase pulse (phase A + phase B), or CCW/CW pulse train
			Input Pulse Form	Line driver (+5V level), open collector (+5V or +12V level)
			Input Pulse Frequency	500kpps max. (200kpps max. at open collector)
Control Signal	Clear signal (input pulse form is same as reference input pulse form)			
I/O Signal	Position Signal Output	Phase A, phase B, phase C : Line driver output.		
	Sequence Input Signal	Servo ON, pole detection start (or control mode switching, zero clamp, reference pulse inhibit), forward / reverse run prohibit, alarm reset, forward/reverse current limit (or internal speed selection)		
	Sequence Output Signal	Servo alarm, alarm codes (3-bit output) : CN1 output terminal is fixed. It is possible to output three types of signals from among : positioning complete (or speed agree), motor moving, servo ready, current limit, speed limit, brake release, warning, and NEAR.		
Built-in Functions	Communications	Interface	Digital operator (hand-held type), RS-422A port for PCs, etc. (RS-232C ports under some conditions)	
		1 : N Communications	N may equal up to 14 when an RS-422A port is used.	
		Axis Address Setting	Set by user setting parameter.	
	Items	Status display, user parameter setting, monitor display, alarm traceback display, JOG run/ auto-tuning operations, and graphing functions for speed/torque reference signal, etc.		
	Auto-tuning	Position/speed loop gain and integral time constant can be automatically set.		
	Dynamic Brake (DB)	Operates at main power OFF, servo alarm, servo OFF or overtravel		
	Regenerative Processing	Regenerative resistor externally mounted (option)		
	Overtravel (OT) Prevention	DB stop, deceleration stop or coast to stop at P-OT, N-OT operation		
	Encoder Divider	Optional division possible		
	Electronic Gearing	0.01 < A/B < 100		
	Internal Speed Setting	3 speeds may be set internally		
	Protection	Overcurrent, overvoltage, undervoltage, regeneration over, overload, main circuit sensor error, heatsink overheat, power open phase, overflow, overspeed, encoder error, runaway, CPU error, parameter error, etc.		
	Analog Monitor Functions for Supervision	Integrates analog monitor connectors for supervision of the speed and force reference signals, etc.		
Display	CHARGE, POWER, 7-segment LED×5 (Integrated digital operator function)			
Others	Reverse connection, zero point search, automatic motor model discrimination function and DC reactor connection terminal for high frequency power suppression function (except for SGDH-75AE-□)			

Dimensions in mm

● Single-phase

SGDH-01AE-□, SGD-02AE-□

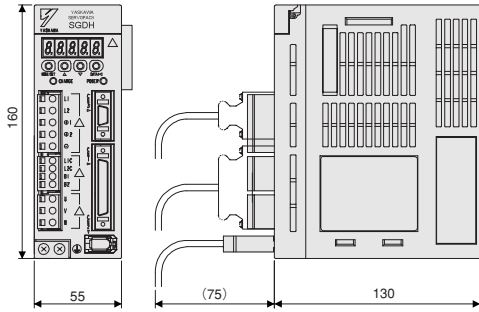

SGDH-04AE-□

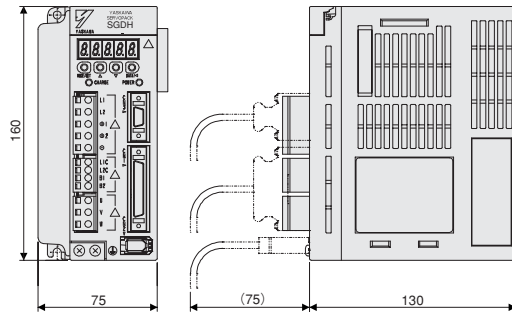

● Three-phase

SGDH-05AE-□ ~ SGD-10AE-□

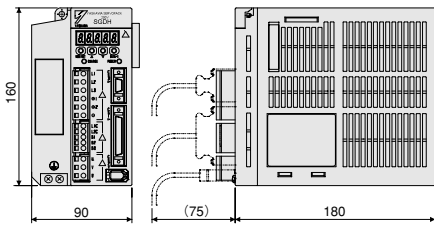

SGDH-15AE-□

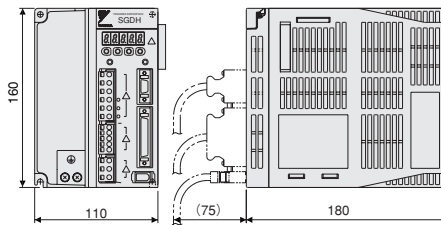

SGDH-20AE-□, SGD-30AE-□

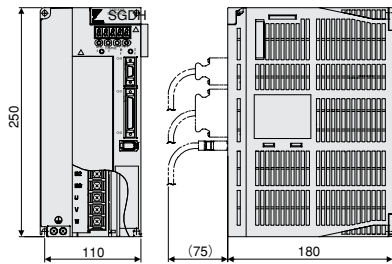

SGDH-50AE-□

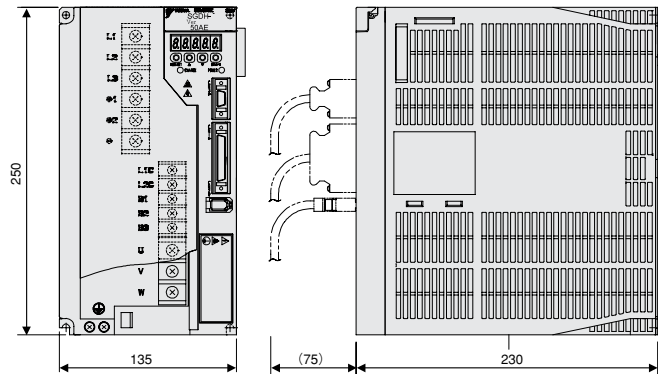

SGDH-75AE-□

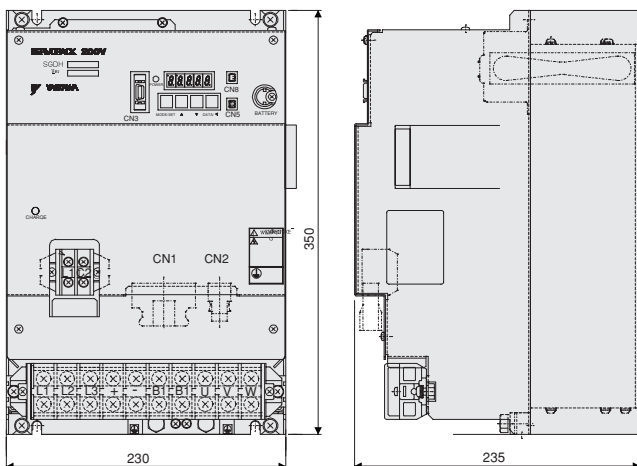

Servodriver(SERVOPACK) Specifications

Connection Diagram

●Single-phase

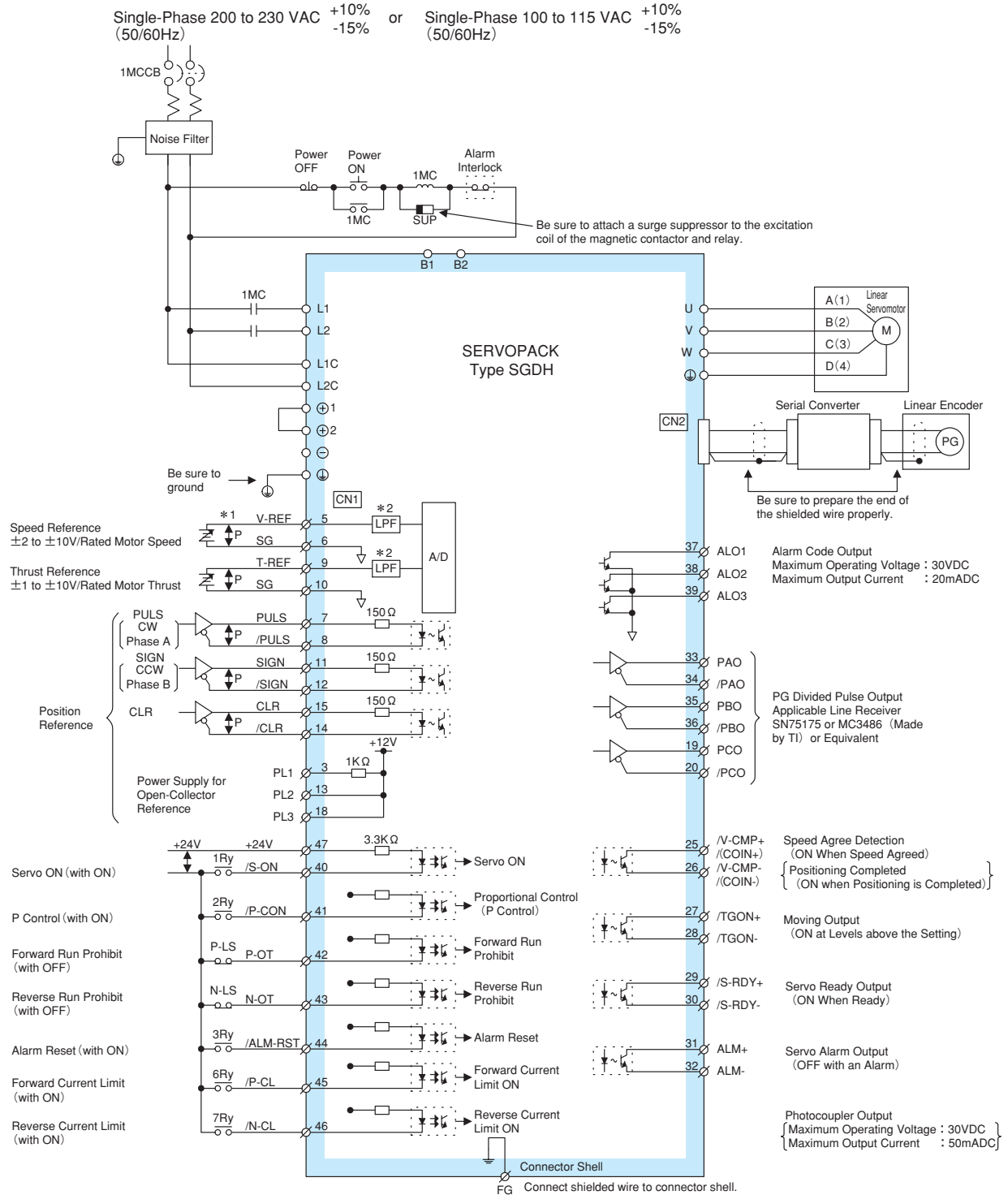

*1 $\overline{\text{P}}$ represents twisted-pair wires.

*2 The time constant for the primary filter is 47 μ s.

● Three-phase

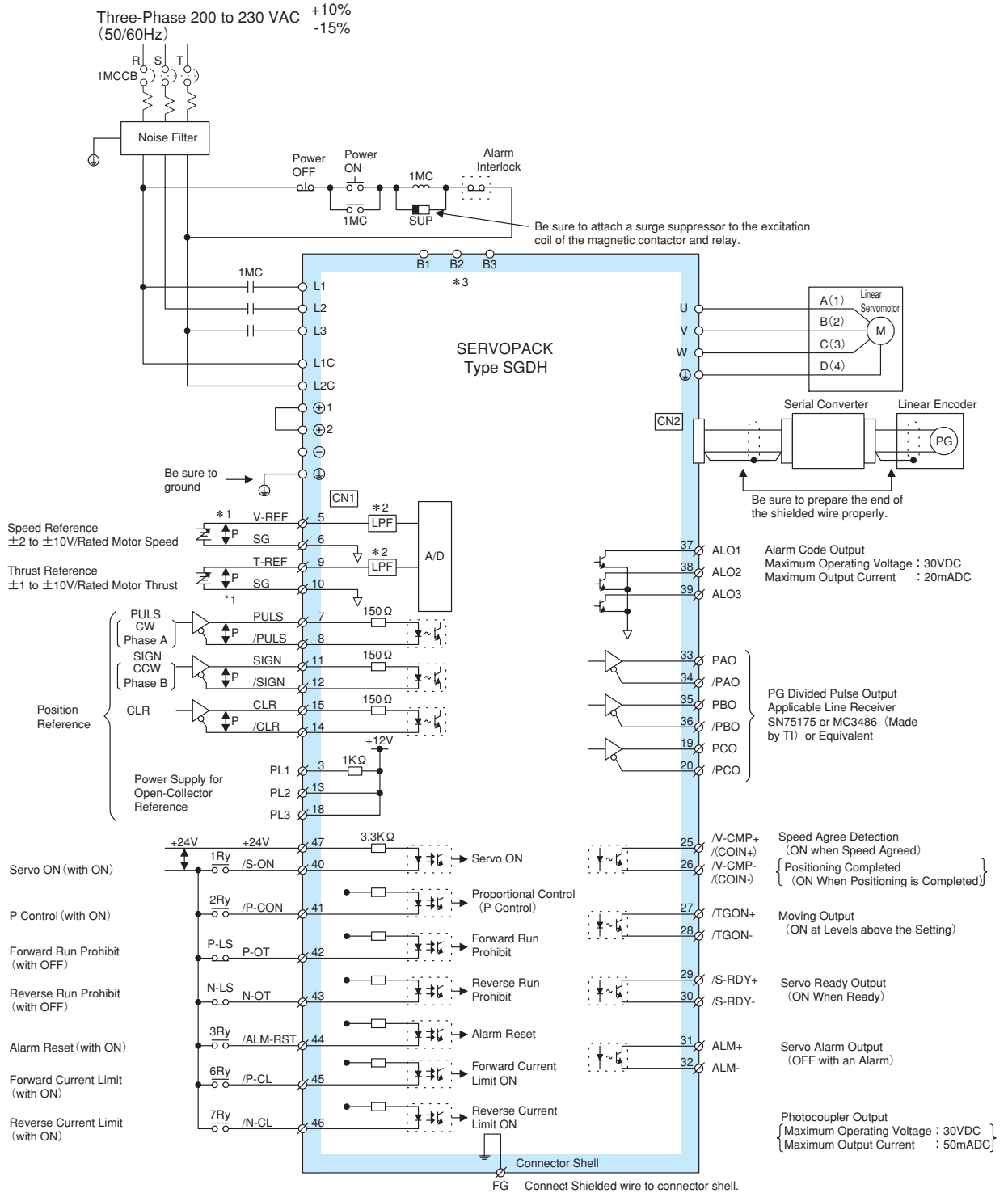

*1 $\overline{\text{P}}$ represents twisted-pair wires.

*2 The time constant for the primary filter is 47 μ s.

*3 When using SERVOPACK of 6.0kW or more, connect an external regenerative resistor between B1 and B2. (B3 terminal is not provided)

Option

Serial Converter (JZDP-A004-□□□)

1N=0.2276 lbs.=0.102kgf
1kg=2.232 lbs.
1mm=0.03937 in.

Characteristics and Specifications

Item	Specifications	
Electrical Characteristics	Power Supply Voltage	+5.0VDC \pm 5% ripple content 5% or less
	Current Consumption*1	120mA Typ. 350mA max.
	Output Resolution	Input analog pitch Subdivided by 1/256
	Max. Frequency Response	250kHz
	Analog Input Signal*2 (Cos, Sin, Ref)	Input differential : 0.4 to 1.2V Input signal level : 1.5 to 3.5V
Hall Sensor Signal Inputs	CMOS level	
Mechanical Characteristics	Mass	150g
	Dimensions	90×60×23mm
	Vibration Resistance	98m/s ² max. (10 to 2500Hz) 3 directions
	Shock Resistance	980m/s ² , (11ms) 3 directions for 2 times
Environment	Operational Temperature	0 to +55°C
	Storage Temperature	-20 to +80°C
	Humidity	20 to 90%RH (non-condensing)

* 1 The current consumption of the linear encoder and hall sensors is not included in this value.

* 2 The system may malfunction if signals outside of this range is applied to these inputs.

Dimensions in mm

● JZDP-A004

(Standard configuration, applicable for most Sine/Cosine output linear encoders)

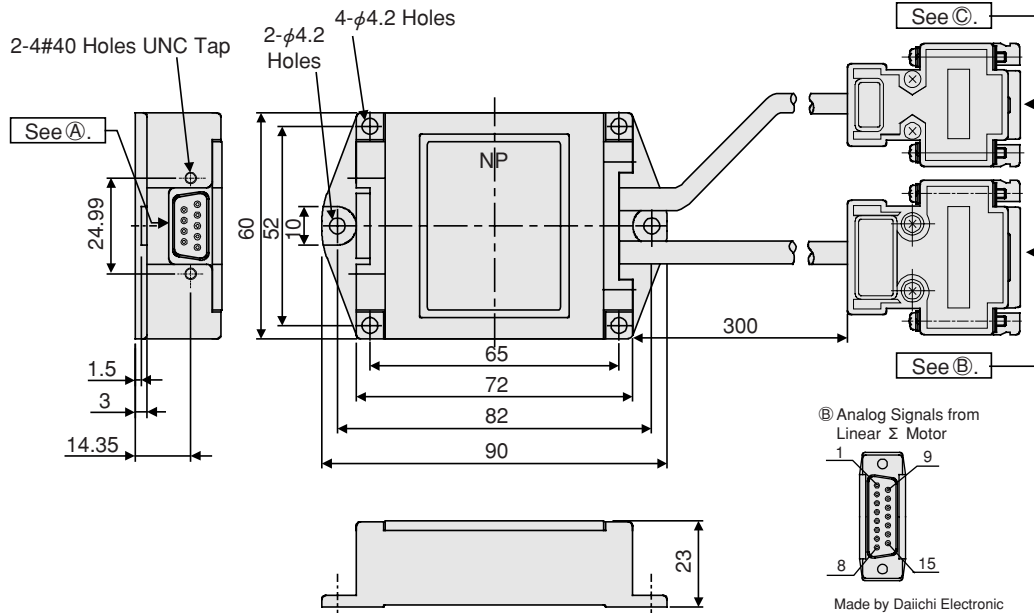

Notes : 1 Do not connect any signals to "Not Used" pins.

2 This connector mates directly with a standard 15-pin D-Sub connector of Renishaw RGH22B/24B/25B linear encoders. For connections to Heidenhain linear encoders, use the optional conversion cable JZSP-CLL20-01 (1m), -03 (3m), -05 (5m). The Renishaw RGH22B's BID and DIR signals are not connected within the Serial Converter.

3 The hall sensor inputs U, V and W are internally pulled up at 10kΩ.

Ⓐ Serial Data Output to SIGMA-II Servodriver

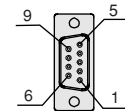

Made by Daiichi Electronic Industries Co., Ltd.
17 Series Connector
Connector : 17JE-13090-02 (D2C) (Socket)

Pin No.	Signal
1	+5V
2	Phase S output
3	Not used
4	Not used
5	0V
6	/Phase S output
7	Not used
8	Not used
9	Not used
Case	Shield

Ⓑ Analog Signals from Linear Σ Motor

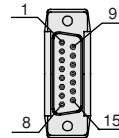

Made by Daiichi Electronic Industries Co., Ltd.
17 Series Connector
Connector : 17JE-13150-02 (D8C) (Socket)

Pin No.	Signal
1	/Cos input (V1-)
2	/Sin input (V2-)
3	Ref input (V0+)
4	+5V
5	5Vs
6	Not used
7	Not used
8	Limit switch (Vg)
9	Cos input (V1+)
10	Sin input (V2+)
11	/Ref input (V0-)
12	0V
13	0Vs
14	Not used
15	Inner
Case	Shield

Ⓒ Hall Sensor Signals from Linear Σ Motor

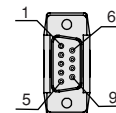

Made by Daiichi Electronic Industries Co., Ltd.
17 Series Connector
Connector : 17JE-13090

Pin No.	Signal
1	+5V
2	Phase U output
3	Phase V output
4	Phase W output
5	0V
6	Not used
7	Not used
8	Not used
9	Not used
Case	Shield

Selecting Motor Force

Comparison with Rotary Motor

1N=0.2276 lbs.=0.102kgf
1kg=2.232 lbs.
1mm=0.03937 in.

Rotary Motor		Linear Motor	
Drive Mechanism			
Load Shaft Rotation Speed N_L (r/min)	$\frac{1000 \times V_L}{P_B}$		
Motor Speed N_M (r/min)	$R \times N_L$		
Inertia Converted into Load Shaft J_l	$(W_w + W_T) \times \left(\frac{P_B}{1000\pi}\right)^2 \times \frac{1}{4}$		
Inertia Converted into Motor Shaft J_M	$J_l \times \left(\frac{1}{R}\right)^2$		
Drive Torque by Load Shaft T_l (N·m)	$\mu \times (W_w + W_T) \times 9.8 \times \left(\frac{P_B}{2000\pi}\right)$	Normal Force F_L (N)	$\frac{\mu \times (W_w + W_T + W_M) \times 9.8}{\eta}$
Connected Motor Shaft T_M (N·m)	$T_l \times \frac{1}{R} \times \frac{1}{\eta}$	Running Power P_o (W)	$\frac{F_L \times V_L}{60}$
Running Power P_o (W)	$\frac{T_M \times 2 \times \pi \times N_M}{60}$	Accel Force F_P (N)	$F_P = (W_w + W_T + W_M) \times \alpha + F_L$
Accel Torque T_P (N·m)	$T_P = \frac{(J_l + J_M) \times 2 \times \pi \times N_M}{60 \times t_a} + T_l$	Decel Force F_S (N)	$F_S = (W_w + W_T + W_M) \times \alpha - F_L$
Decel Torque T_S (N·m)	$T_S = \frac{(J_l + J_M) \times 2 \times \pi \times N_M}{60 \times t_d} - T_l$	Required Force F_{rms} (N)	$F_{rms} = \sqrt{\frac{F_P^2 \times t_a + F_L^2 \times t_c + F_S^2 \times t_d}{T}}$
Required Torque T_{rms} (N·m)	$T_{rms} = \sqrt{\frac{T_P^2 \times t_a + T_l^2 \times t_c + T_S^2 \times t_d}{T}}$		
		Estimated Winding Temperature θ_c (°C)	$\theta_c = (F_{rms}/K_m)^2 \times R_{th} + \theta$

Selection Example

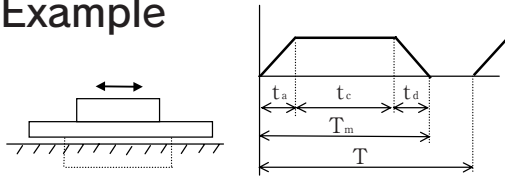

Load speed $V_L = 120\text{m/min}$
 Workpiece mass $W_w = 1\text{kg}$
 Table mass $W_T = 2\text{kg}$
 Friction coefficient $\mu = 0.2$
 Mechanical efficiency $\eta = 0.9$
 Positioning time $T_m = 0.4\text{s}$
 Accel time $t_a = 0.02\text{s}$
 1 cycle time $T = 0.5\text{s}$

• Temporary Selection

- ① Normal load force = $0.2 \times (1+2) \times 9.8 = 5.88$ (N)
- ② Load accel force = $(1+2) \times 120 / 60 / 0.02 + 5.88 = 306$ (N)

From ②, select SGLGW-40A365A whose peak force is 420N
 Specifications of SGLGW-40A365A

Continuous force : 140N Peak force: 420N Moving coil mass: 0.91kg Motor constant: 13.5 (N/√W)

Thermal resistance: 0.65(K/W)
 (Ambient temperature (θ) : 25°C)

• Servomotor Checking

- ③ Normal force = $0.2 \times (1+2+0.91) \times 9.8 / 0.9 = 8.5$ (N)
- ④ Accel force = $(1+2+0.91) \times 120 / 60 / 0.02 + 8.5 = 400$ (N) < Peak force (applicable)
- ⑤ Decel force = $(1+2+0.91) \times 120 / 60 / 0.02 - 8.5 = 383$ (N) < Peak force (applicable)

- ⑥ Required force = $\sqrt{\frac{400^2 \times 0.02 + 8.5^2 \times 0.36 + 383^2 \times 0.02}{0.5}} = 111$ (N) < Rated force (applicable)

- ⑦ Estimated winding temperature: $(111/13.5)^2 \times 0.65 + 25 = 69$ (°C) < 130 (°C) (applicable)

Ordering Reference

Servodriver (SERVOPACK) SGDH

● Without Option Unit

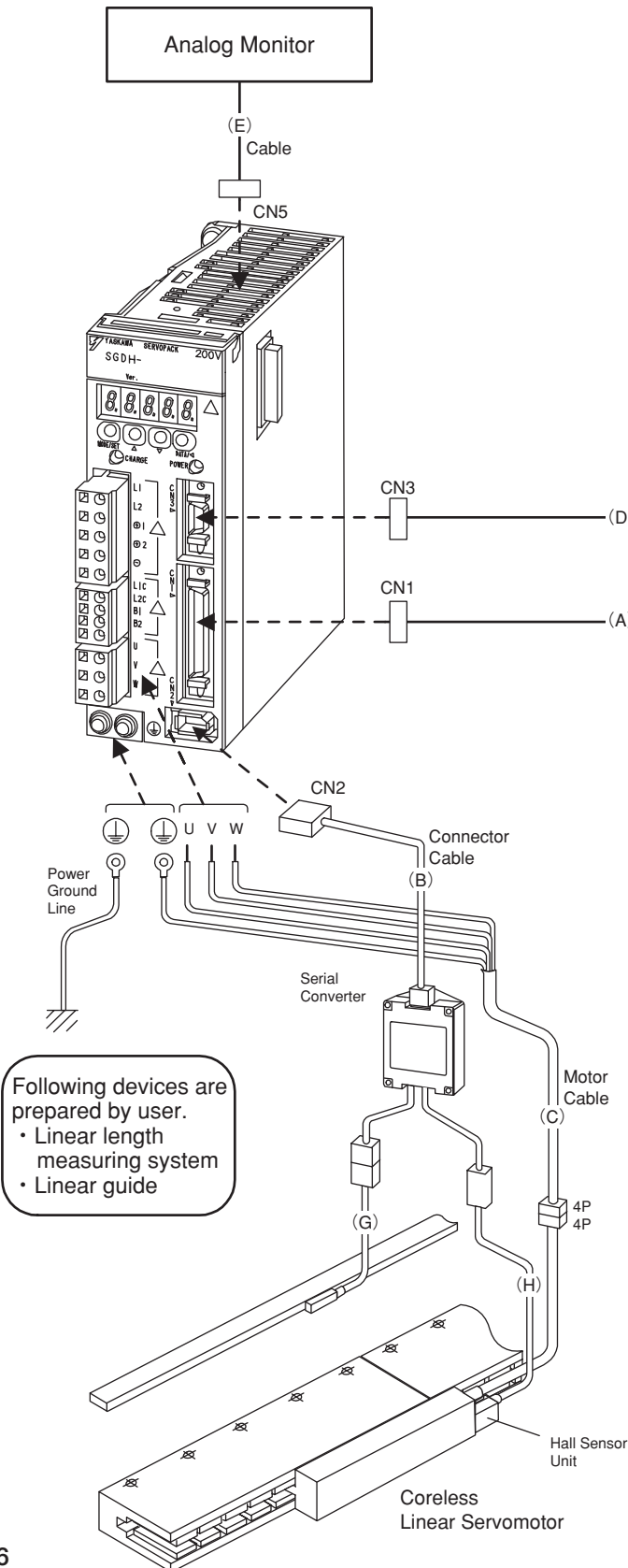

Host Controller

Can be connected to a YASKAWA host controller. MP910, MP920, and other motion controllers.

Digital Operator

Type JUSP-OP02A-2

Sets each user Parameter and displays the command status and alarms. Can also be used for communications with a PC.

Personal Computer

Connection Cable Type : JZSP-CMS01 to 03

Name	Servodriver Type	Max. Applicable Motor Type	Specifications (Input Voltage, Capacity)
Servodriver and Servomotor	SGDH-01AE	SGLGW-40A140	AC Single-phase 200 to 230V,100W
	SGDH-02AE	SGLGW-40A253	AC Single-phase 200 to 230V,200W
		SGLFW-20A090	
		SGLFW-20A120	
	SGDH-04AE	SGLGW-40A365	AC Single-phase 200 to 230V,400W
		SGLGW-60A253	AC Three-Phase 200 to 230V,500W
	SGDH-05AE	SGLFW-35A230	
	SGDH-08AE	SGLGW-60A365	AC Three-phase 200 to 230V,800W
		SGLFW-50A200	
	SGDH-10AE	SGLTW-20A170	AC Three-phase 200 to 230V,1kW
		SGLGW-60A365	
		SGLFW-50A380	
	SGDH-15AE	SGLFW-1ZA200	AC Three-phase 200 to 230V,1.5kW
		SGLTW-20A460	
SGLTW-35A320			
SGDH-20AE	SGLFW-1ZA380	AC Three-phase 200 to 230V,2kW	
	SGLTW-35A460		
	SGLTW-40A400		
SGDH-30AE	SGLTW-40A600	AC Three-phase 200 to 230V,3kW	
SGDH-50AE	SGLTW-80A400	AC Three-phase 200 to 230V,5kW	
SGDH-75AE	SGLTW-80A600	AC Three-phase 200 to 230V,7.5kW	
SGDH-01BE	SGLGW-40A140	AC Single-phase 100 to 115V,100W	
	SGDH-02BE	SGLGW-40A253	AC Single-phase 100 to 115V,200W
SGLGW-60A140			

1N=0.2276 lbs.=0.102kgf
 1kg=2.232 lbs.
 1mm=0.03937 in.

Option

Name		Type	Specifications
Digital Operator	Digital Operator	JUSP-OP02A-2	A 1 m cable is attached.
	Cable	JZSP-CMS00-1	1m
		JZSP-CMS00-2	2m
JZSP-CMS00-3		3m	
			Required only when using JUSP-OP02A-1, the digital operator for Σ Series.
Noise Filter	SUP-P5H-EPR-4		Single-phase 5A
	SUP-P8H-EPR-4		Single-phase 8A
	SUP-P10H-EPR-4		Single-phase 10A
	SUP-P15H-EPR-4		Single-phase 15A
	SUP-P20H-EPR-4		Single-phase 20A
	LF3200		Three-phase 20A

Cables and Connectors

Name		Type	Specifications	
(A) CN1 Connector for I/O Signals	Connector Terminal Conversion Unit	JUSP-TA50P	Terminal block and connection cable 0.5m	
	Cable with connector on only Servodriver Side	JZSP-CK101-1	1m	
		JZSP-CK101-2	2m	
		JZSP-CK101-3	3m	
Connector Kit (for CN1)	JZSP-CK19			
(B) CN2 Serial Converter	Cable with Connectors on Both Ends	JZSP-CLP20-03	3m	
		JZSP-CLP20-05	5m	
		JZSP-CLP20-10	10m	
		JZSP-CLP20-15	15m	
		JZSP-CLP20-20	20m	
		(C) Servodriver Terminal Motor	Motor Cable (for Main Circuit)	JZSP-CLN11-01 (1m)
JZSP-CLN11-03 (3m)	All types in SGLGW series			
JZSP-CLN11-05 (5m)				
JZSP-CLN11-10 (10m)				SGLFW-20
JZSP-CLN11-15 (15m)	SGLFW-35			
JZSP-CLN21-01 (1m)	Applicable linear Servomotor type			
JZSP-CLN21-03 (3m)				SGLFW-50
JZSP-CLN21-05 (5m)				
JZSP-CLN21-10 (10m)	SGLFW-1Z			
JZSP-CLN21-15 (15m)	SGLTW-20			
JZSP-CLN21-15 (15m)	SGLTW-35			
JZSP-CLN39-01 (1m)	Applicable linear Servomotor type			
JZSP-CLN39-03 (3m)				SGLTW-40
JZSP-CLN39-05 (5m)				
JZSP-CLN39-10 (10m)	SGLTW-80			
JZSP-CLN39-15 (15m)				
(D) CN3 Setting Device	Cable for Digital Operator	—	Attached to digital operator (JUSP-OP02A-2)	
	Cable for PC	JZSP-CMS01	2m D-SUB 25-pin	
		JZSP-CMS02	2m D-SUB 9-pin	
JZSP-CMS03	2m Half pitch 14-pin			
(E) CN5 Analog Monitor	Cable for Analog Monitor	DE9404559	1m	
(G) Serial Converter Linear Encoder	Special Cable for Renishaw Linear Encoders	JZSP-CLL00-01	1m D-SUB 15-pin	
		JZSP-CLL00-03	3m D-SUB 15-pin	
		JZSP-CLL00-05	5m D-SUB 15-pin	
		JZSP-CLL00-10	10m D-SUB 15-pin	
		JZSP-CLL00-15	15m D-SUB 15-pin	
	Conversion Cable for Heidenhain Linear Encoders	JZSP-CLL20-01	1m D-SUB 15-pin	
		JZSP-CLL20-03	3m D-SUB 15-pin	
		JZSP-CLL20-05	5m D-SUB 15-pin	
(H) Serial Converter Hall Sensor	Special Cable for Hall Sensor	JZSP-CLL10-01	1m	
		JZSP-CLL10-03	3m	
		JZSP-CLL10-05	5m	
		JZSP-CLL10-10	10m	
		JZSP-CLL10-15	15m	

Linear Σ SERIES

IRUMA BUSINESS CENTER

480, Kamifujisawa, Iruma, Saitama 358-8555, Japan
Phone 81-42-962-5696 Fax 81-42-962-6138

YASKAWA ELECTRIC AMERICA, INC.

2121 Norman Drive South, Waukegan, IL 60085, U.S.A.
Phone 1-847-887-7000 Fax 1-847-887-7370

MOTOMAN INC. HEADQUARTERS

805 Liberty Lane West Carrollton, OH 45449, U.S.A.
Phone 1-937-847-6200 Fax 1-937-847-6277

YASKAWA ELÉTRICO DO BRASIL COMÉRCIO LTD.A.

Avenida Fagundes Filho, 620 Bairro Saude-Sao Páulo-SP, Brazil CEP: 04304-000
Phone 55-11-5071-2552 Fax 55-11-5581-8795

YASKAWA ELECTRIC EUROPE GmbH

Am Kronberger Hang 2, 65824 Schwalbach, Germany
Phone 49-6196-569-300 Fax 49-6196-569-312

Motoman Robotics Europe AB

Box 504 S38525 Torsås, Sweden
Phone 46-486-48800 Fax 46-486-41410

Motoman Robotec GmbH

Kammerfeldstraße 1, 85391 Allershausen, Germany
Phone 49-8166-90-100 Fax 49-8166-90-103

YASKAWA ELECTRIC UK LTD.

1 Hunt Hill Orchardton Woods Cumbernauld, G68 9LF, United Kingdom
Phone 44-1236-735000 Fax 44-1236-458182

YASKAWA ELECTRIC KOREA CORPORATION

Kfpa Bldg #1201, 35-4 Youido-dong, Yeongdungpo-Ku, Seoul 150-010, Korea
Phone 82-2-784-7844 Fax 82-2-784-8495

YASKAWA ELECTRIC (SINGAPORE) PTE. LTD.

151 Lorong Chuan, #04-01, New Tech Park Singapore 556741, Singapore
Phone 65-6282-3003 Fax 65-6289-3003

YASKAWA ELECTRIC (SHANGHAI) CO., LTD.

No.18 Xizang Zhong Road, Room 1805, Harbour Ring Plaza Shanghai 20000, China
Phone 86-21-5385-2200 Fax 86-21-5385-3299

YATEC ENGINEERING CORPORATION

4F., No.49 Wu Kong 6 Rd, Wu-Ku Industrial Park, Taipei, Taiwan
Phone 886-2-2298-3676 Fax 886-2-2298-3677

YASKAWA ELECTRIC (HK) COMPANY LIMITED

Rm. 2909-10, Hong Kong Plaza, 186-191 Connaught Road West, Hong Kong
Phone 852-2803-2385 Fax 852-2547-5773

BEIJING OFFICE

Room No. 301 Office Building of Beijing International Club, 21
Jianguomenwai Avenue, Beijing 100020, China
Phone 86-10-6532-1850 Fax 86-10-6532-1851

TAIPEI OFFICE

9F, 16, Nanking E. Rd., Sec. 3, Taipei, Taiwan
Phone 886-2-2502-5003 Fax 886-2-2505-1280

SHANGHAI YASKAWA-TONGJI M & E CO., LTD.

27 Hui He Road Shanghai China 200437
Phone 86-21-6553-6060 Fax 86-21-5588-1190

BEIJING YASKAWA BEIKE AUTOMATION ENGINEERING CO., LTD.

30 Xue Yuan Road, Haidian, Beijing P.R. China Post Code: 100083
Phone 86-10-6233-2782 Fax 86-10-6232-1536

SHOUGANG MOTOMAN ROBOT CO., LTD.

7, Yongchang-North Street, Beijing Economic Technological Investment & Development Area,
Beijing 100076, P.R. China
Phone 86-10-6788-0551 Fax 86-10-6788-2878



YASKAWA ELECTRIC CORPORATION

YASKAWA

In the event that the end user of this product is to be the military and said product is to be employed in any weapons systems or the manufacture thereof, the export will fall under the relevant regulations as stipulated in the Foreign Exchange and Foreign Trade Regulations. Therefore, be sure to follow all procedures and submit all relevant documentation according to any and all rules, regulations and laws that may apply.

Specifications are subject to change without notice for ongoing product modifications and improvements.

© 2002-2004 YASKAWA ELECTRIC CORPORATION. All rights reserved.

LITERATURE NO. KAE-S800-39.10

Printed in Japan January 2004 01-3 ④
03-10④