

LCC-10 Controller

LCC-10 Controller Specification and Features

Description	Brushless & Servo motor controller/driver
Operating Modes	Position, Velocity, Torque, Homing, Learned Position
Filter Algorithm	Position – PID + Velocity & Acceleration Feed-Forward Torque – PI
Homing Methods	Physical limit, Index
Learned Positions	Stores 200 positions
Max Loop Rate	1 milliseconds (1 KHz)
Trajectory Generator	Trapezoidal
Position Feedback	Incremental Encoder, up to 2 Million counts per second
Output	PWM motor drive, 2A RMS, 4A peak
PWM Frequency	39 KHz
Encoder Input	Single-ended or Differential
Encoder Supply Voltage	5 VDC
General Purpose I/O	4 Digital Inputs and Outputs (TTL)
Analog I/O	1 Analog Input (0-5V) 1 Analog Output (0-10V) for Hardware v1.1 and higher (10-bit DAC for LCC-10, 16-bit DAC for LCC-11)
Communication Interface	RS232 and CAN interface
Supply Voltage	24 - 48V (*)
Motor Voltage	24 - 48V
Dimensions	Approximately 4.0" Long by 3.3" Wide by 1.1" Thick
Weight	Approximately 1 lb.
Safety	Polarity Inversion protection, over-current protection (I ₂ T), current output limiter
Controller Modes	Stand-Alone or Slave
Memory	16 Kb NVM, 100 Registers
Phasing	Auto-phasing or Manual phasing for brushless motors
Communication	RS232 (Baud rate 115200Bd), CAN (CiA 301, CiA 305, CiA 402)

(*) The power supply must be able to stabilize the back EMF of long stroke multipole actuators.
A power supply capacitor of at least 6800µF/63 V is required.

Pin Out

Actuator Interface

Pin	Function
1	A+
2	Z+
3	B+
4	+5V
5	+5V
6	+5V
7	Not Connected
8	Not Connected
9	A-
10	Z-
11	B-
12	Ground
13	Ground
14	Not Connected
15	Not Connected

Communication 1 (Right)

Pin	Function
1	CAN High
2	CAN Low
3	Not Connected
4	RS-232 Transmission
5	Ground
6	Not Connected

Communication 2 (Left)

Pin	Function
1	CAN High
2	CAN Low
3	RS-232 Reception
4	RS-232 Transmission
5	Ground
6	Not Connected

Power

Pin	Function
1	Ground
2	+24/48 V
3	U (motor)
4	V (motor)
5	W (motor)
6	Not Connected

I/O

Pin	Function
1	Not Connected
2	Not Connected
3	Digital Input 2
4	Digital Input 0
5	Ground
6	Analog Output
7	Not Connected
8	Digital Output 2
9	Digital Output 0
10	Not Connected
11	Not Connected
12	Digital Input 3
13	Digital Input 1
14	Ground
15	Not Connected
16	Not Connected
17	Digital Output 3
18	Digital Output 1
19	+5V
20	+5V
21	+5V
22	+5V
23	Ground
24	Analog Input
25	Not Connected
26	Not Connected

LCC-10 dimensions

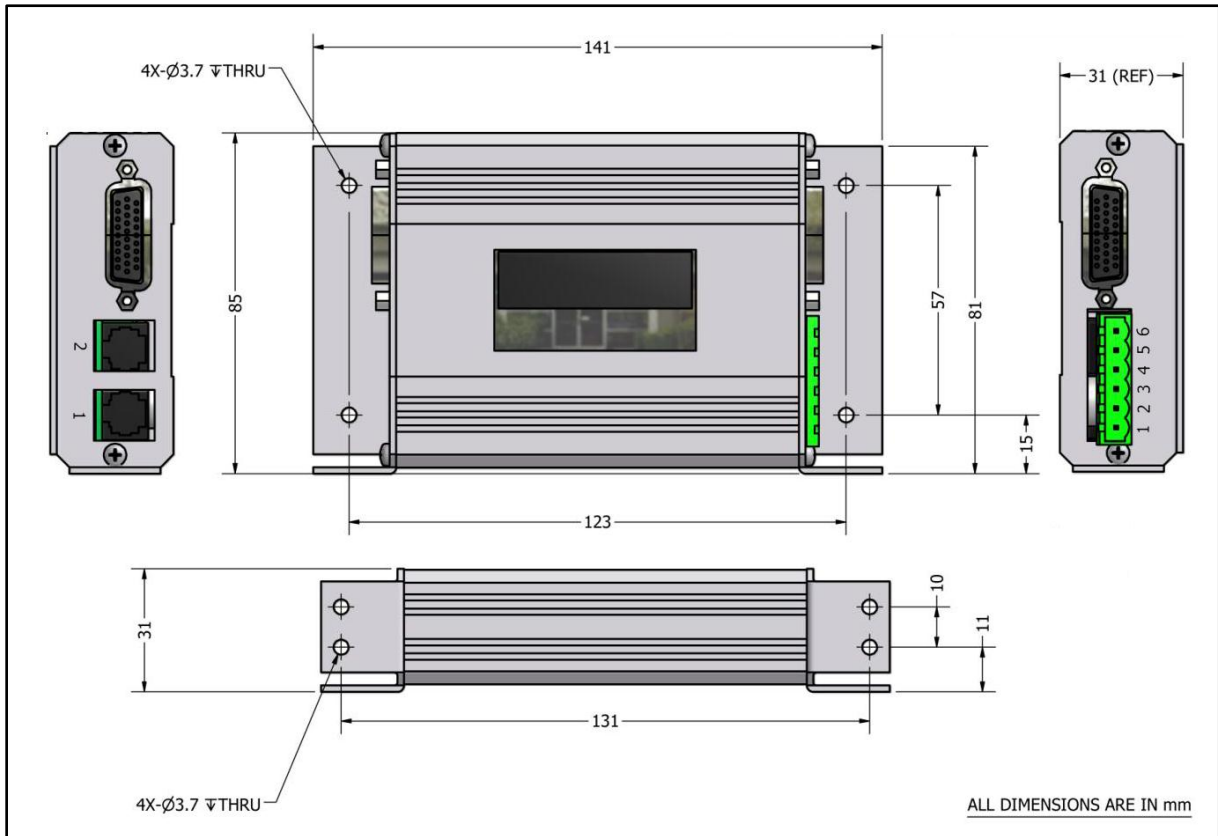

Connecting an Actuator

MultiPole Actuator

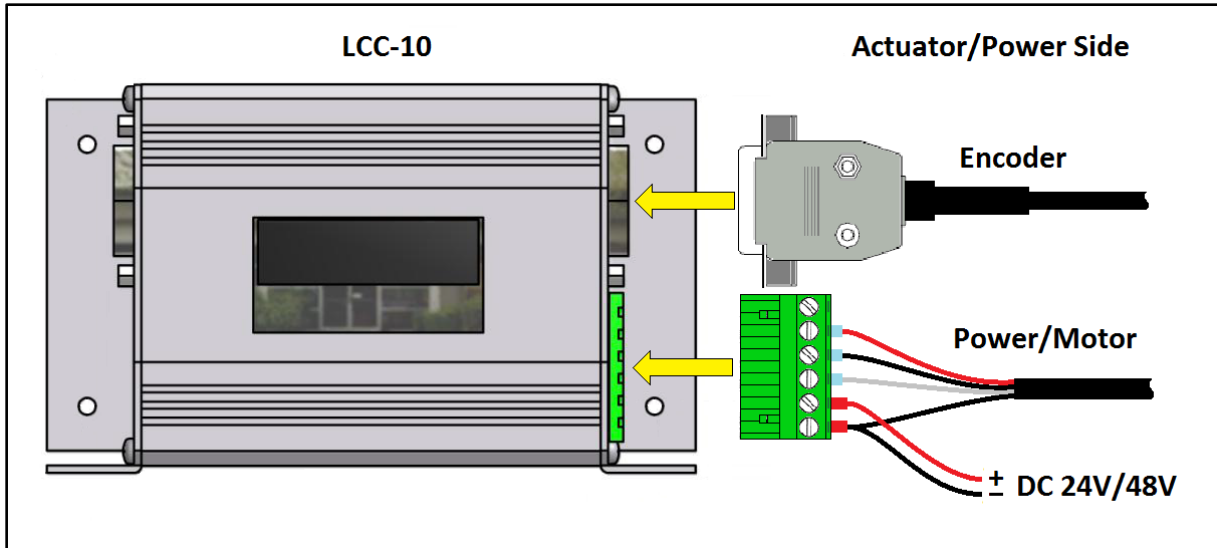

SinglePole Actuator

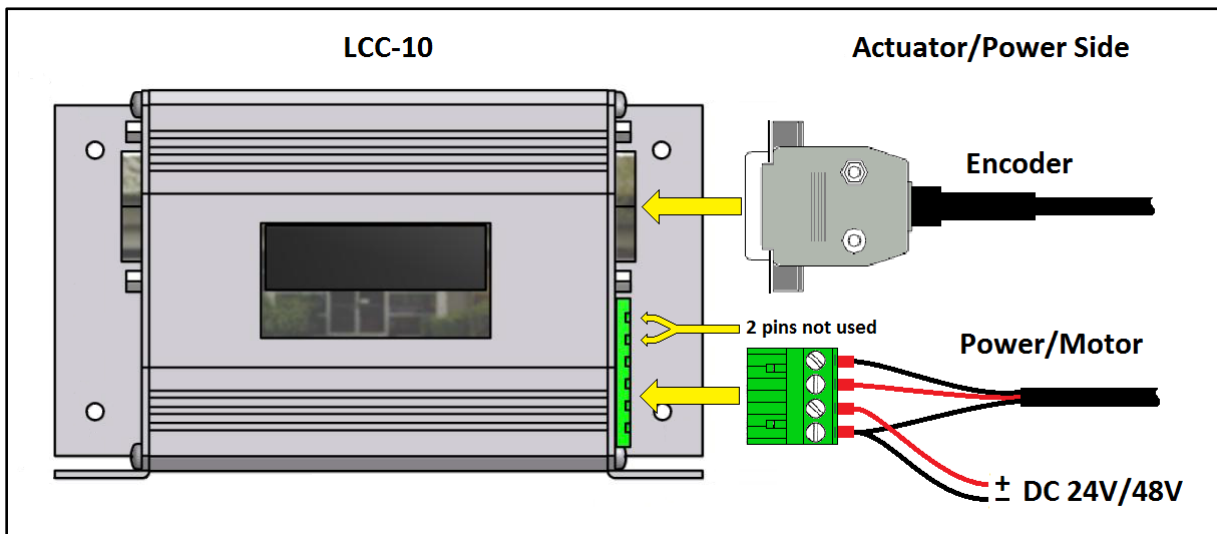

Connecting Communication

Serial Communication using RS232 kit

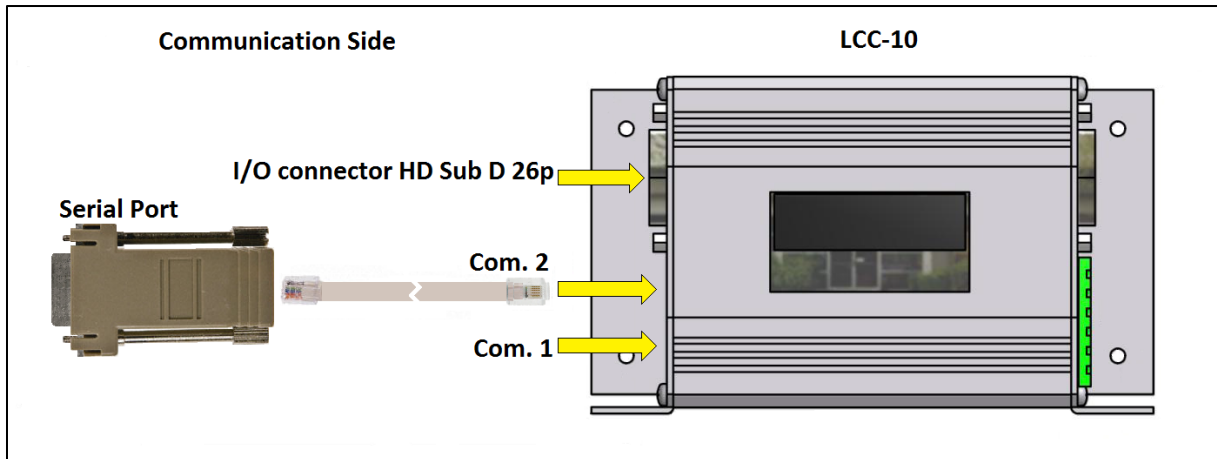

The RS232 kit contains:

1. Serial port connector (Sub D 9 pins on one side and the RJ25 socket on the other side)
2. RJ25 cable (3 meter long, standard RJ cable, 1 on 1, with 6 wires)

Connecting Multi Axis Acces Using Daisy Chain kit + RS232 kit

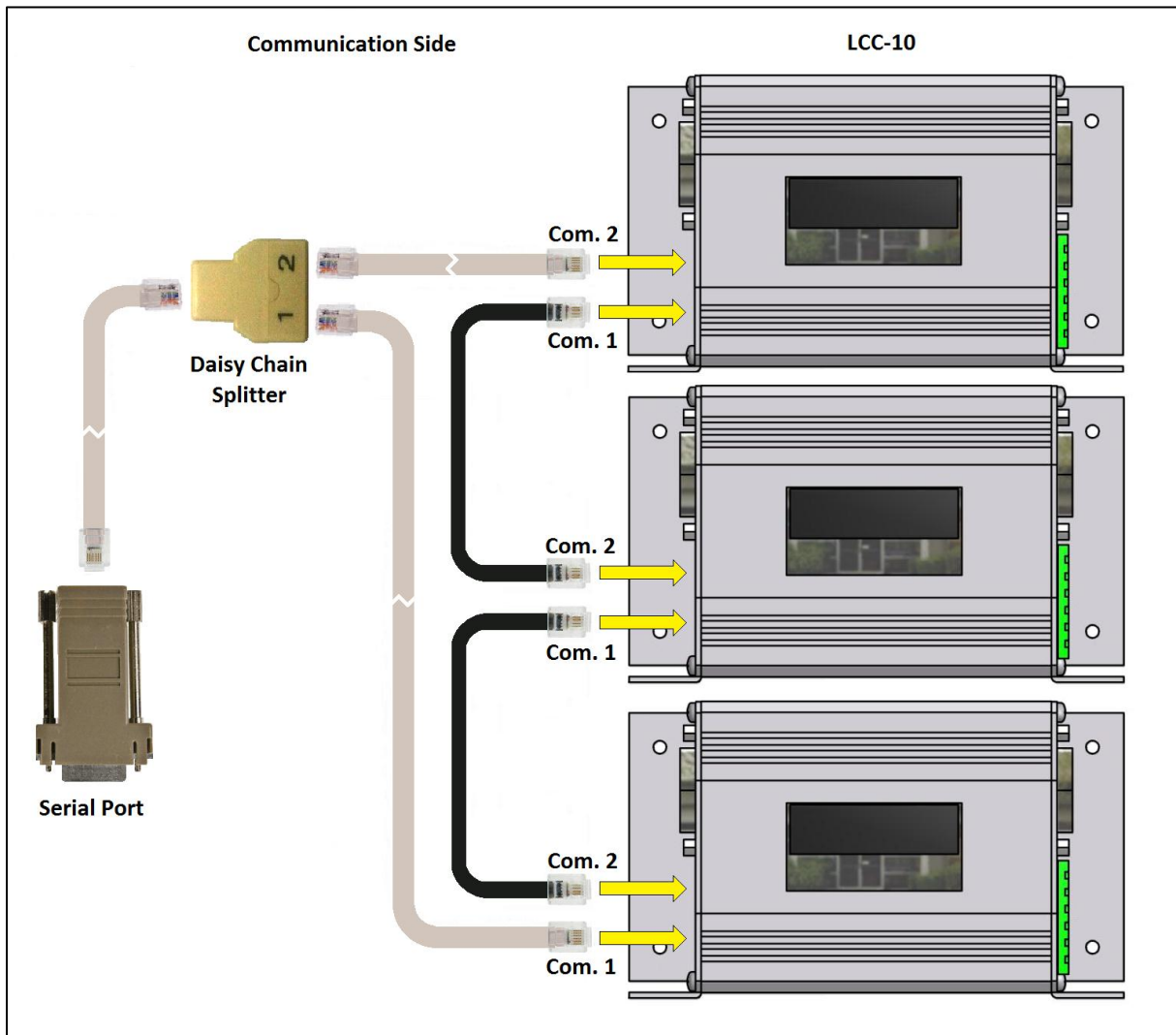

The Daisy Chain Kit contains:

1. Daisy Chain Splitter (containing 3 x RJ25 socket)
2. 2 x RJ25 cable (Gray, 30 centimeter long , standard RJ cable, 1 on 1, with 6 wires)
3. 1 x RJ14 chain link cable (Black, 20 centimeter long, two wires crossed, 4 wires)

More RJ14 chain link cables to expand to 3, 4 or more controllers in the daisy chain can be ordered seperatly. The RS232 kit is not included in the Daisy Chain kit.